



Compressed Air & Gas
Purification for Every Application



Heatless Regenerative Desiccant Dryer

Off Shore E-Series



Off Shore E-Series

70 - 5,000 SCFM

The Aircel Off Shore E-Series is a fully automatic Dual Tower Heatless Regenerative Compressed Air Dryer with an integrated Energy Management Purge Reduction System. The Offshore series has all the energy saving features of the AHLD-E series plus corrosion resistance. The paint is upgraded to a corrosion resistant UV resistant industrial coating that has a field proven long field life. In addition no yellow metals are present eliminating easily corroded materials.

Delivering Energy Efficient & Purge Reduction Control

The Aircel Programmable Controller (APC) and Energy Management System (EMS) is standard on the AHLD. This energy-saving demand cycle reduces purge air and optimizes dryer performance by monitoring the moisture fast and early in the middle portion of the tower desiccant bed. This control panel automatically adjusts the regeneration cycle maintaining dew point and extending the drying cycle. Switching is less frequent, reducing dryer maintenance and fully utilizing desiccant capacity. This addition will improve reliability and performance while sustaining a constant dew point. The end result is an overall purge reduction and significant energy savings.



Advantages

- Accurate moisture sensing for precise dew point
- Heatless adsorption provides maximum purge air efficiency
- Immediate energy savings and efficient purge design
- Controller displays energy savings, cycle modes, dew point selection, service reminders and alarm conditions

Maximize your return-on-investment automatically with the AHLD E-Series. The Energy Management System delivers significant energy savings in direct relation to load variations from your air demands.

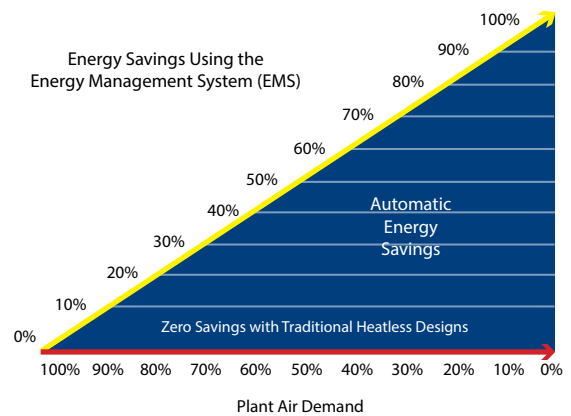

How It Works

Moisture saturated compressed air enters the coalescing pre filter (F1) where aerosols are coalesced then drained via an automatic drain system. The moist water vapor-laden inlet air free of liquid water flows to the inlet of the dryer through the APV (Automatic Piston Valve) (V1) which diverts the inlet air to one of the towers, in this example tower (T1). Air flows upward through the adsorbent bed removing the moisture vapor, the dried airflow exits the tower through the outlet APV valve (V2) flowing to the outlet particulate after filter (F2) which removes particulates from the air stream. Clean and dry air now flows to the process air distribution system.

Visit our website for a detailed description of the AHLD regeneration process under the products section.



AHLD E-Series

Standard Features & Benefits

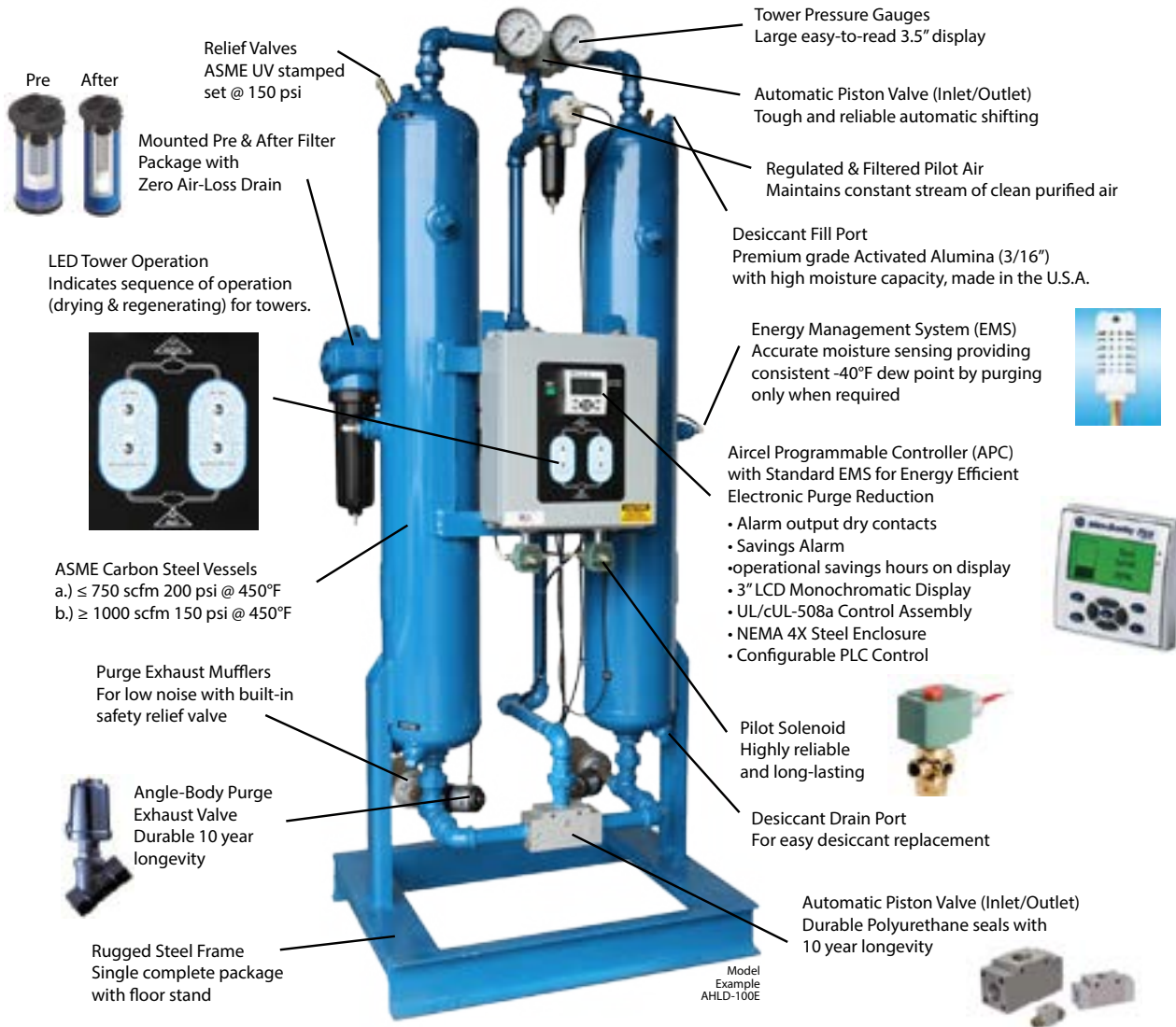

Additional Standard Features

- Remote start/stop control
- Fail-safe design: failure of power and/or pilot air causes the purge exhaust valves to close, uninterrupted drying
- Stainless steel desiccant supports and air diffusers to prevent channeling
- Counter-current regeneration, upflow drying, and downflow depressurization
- High performance butterfly valves (≥ 1000 scfm models)
- Easy installation with single point connection for electrical and inlet/outlet air
- Adjustable (5 & 10 min.) NEMA cycle
- Corrosion resistant
- SS control air tubing
- No yellow metals

Optional Structural Features

- All-pneumatic control package (no electricity required)
- Pre-piped filters and by-pass valve packages
- High inlet pressure up to 7000 psig
- -100°F pressure dew point
- NEMA 7

Optional Controller Features

- Failure-to-shift alarm
- High-inlet temperature alarm
- Dew point monitor
- Pressure alarm
- Visual moisture indicator
- Optional communications: Profibus-DP, AS-I, CANopen, DeviceNet, and Ethernet

Model Comparison & Specifications

Part Number	Model	Capacity ¹ (scfm)	Connection	Dimensions (in.)			Weight (lbs)
				H	L	W	
	AHLD-70 E	70	3/4" NPT	73	26	22	410
	AHLD-100 E	100	1" NPT	75	30	24	490
	AHLD-150 E	150	1" NPT	75	30	24	560
	AHLD-200 E	200	1-1/2" NPT	85	34	24	800
	AHLD-250 E	250	1-1/2" NPT	85	34	24	870
	AHLD-300 E	300	1-1/2" NPT	86	46	30	990
	AHLD-350 E	350	2" NPT	87	46	30	1020
	AHLD-450 E	450	2" NPT	87	46	30	1140
	AHLD-500 E	500	2" NPT	89	50	30	1250
	AHLD-600 E	600	2" NPT	89	50	30	1450
	AHLD-750 E	750	2" NPT	90	50	30	1850
	AHLD-1000 E	1000	3" FLG	94	66	40	2800
	AHLD-1250 E	1250	3" FLG	98	70	40	4000
	AHLD-1500 E	1500	3" FLG	99	70	40	4600
	AHLD-2000 E	2000	4" FLG	109	82	50	5800
	AHLD-2500 E	2500	CF				
	AHLD-3000 E	3000	CF				
	AHLD-3500 E	3500	CF				
	AHLD-4000 E	4000	CF				
	AHLD-4500 E	4500	CF				
	AHLD-5000 E	5000	CF				

¹Capacity rated in accordance with CAGI ADF 200 @ 100 psig, 100°F Inlet, 100°F Ambient and a PDP of -40°F.
 Operating Pressure: 60-190 psig (models 70-750) and 60-140 psig (models 1000-5000).
 Ambient Air Temperature: 38°-105°F. Inlet Air Temperature: 40°F-100°F.
 Standard Power Supply: 115 VAC, consult factory for other options available.

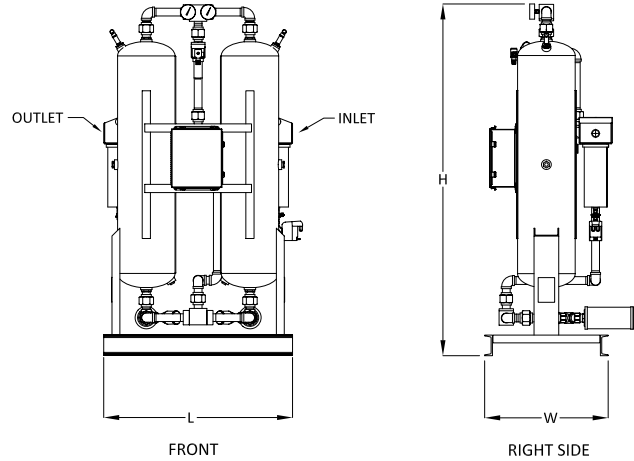

Recommended Installation

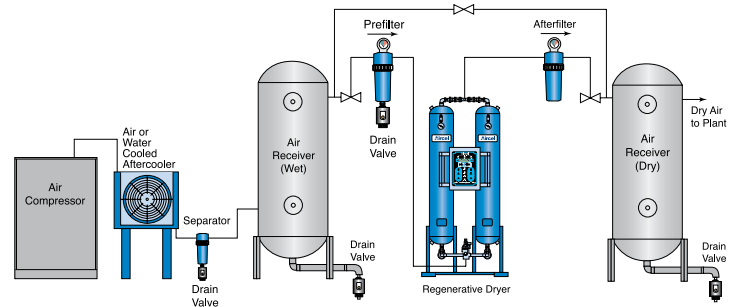

Capacity Correction Factors

To Size the Dryer Capacity for Actual Conditions

$$\text{Adjusted Capacity} = \text{scfm} \times C1 \times C2$$

To calculate the capacity of a given dryer based on non-standard operating conditions, multiply the standard capacity by the appropriate correction factor(s).

EXAMPLE: Dryer Model: AHLD-100
 Standard Capacity: 100 scfm
 Actual Operating Conditions: 120 psig working pressure: C1 = 1.18
 100°F inlet temperature: C2 = 1.0
 Adjusted Capacity = 100 scfm x 1.18 x 1.0 = 118 scfm

To Select the Dryer Model for Actual Conditions

$$\text{Adjusted Capacity} = \text{scfm} / C1 / C2$$

To choose a dryer based on a given flow at non-standard operating conditions, divide the given flow by the appropriate correction factor(s).

EXAMPLE: Given Flow: 350 scfm
 Actual Operating Conditions: 120 psig working pressure: C1 = 1.18
 100°F inlet temperature: C2 = 1.0
 Adjusted Capacity = 350 scfm / 1.18 / 1.0 = 296.6 scfm
 Selected Dryer Model: AHLD-300

The Compressed Air and Gas Institute (CAGI) has developed standards to protect users of compressed air & gas equipment. ADF200 the current standard for desiccant compressed air dryers, specifies the dryers performance to be rated at 100°F inlet temperature, 100°F

ambient temperature, and 100 psig system pressure. To adjust the dryer capacity from these "CAGI conditions" to your specific application, please use the correction factors below for differing system pressures (C1) and inlet air temperatures (C2).

Capacity correction factors for system air pressure (C1)

System Pressure (psig)	60	70	80	90	100	110	120	130	140	150
Correction Factor	0.65	0.73	0.82	0.91	1	1.09	1.18	1.27	1.35	1.44

*For inlet pressure above 150 psi (models 1000 +), consult factory

Capacity correction factors for inlet air temperature (C2)

Inlet Temperature (°F)	70	80	90	100	105*	110*	115*	120*
Correction Factor	1.2	1.15	1.10	1	0.9	0.8	0.7	0.6

*For inlet temperature above 100°F, molecular sieve desiccant is required



Due to a continuous program of product improvement, specification and dimensions are subject to change without notice.

AIRCEL
 323 Crisp Circle
 Maryville, Tennessee 37801
 www.AircelDryers.com

PHONE
 (800) 767-4599
 Local: (865) 681-7066
 Fax: (865) 681-7069

SALES INFORMATION
 sales@airceldryers.com
 REQUEST LITERATURE:
 litrequest@airceldryers.com