

# portable dew point monitor

## FEATURES

- provides accurate, stable dew point or moisture measurements where and when you need it - reliably and cost effectively
- for measuring dew point or moisture content in compressed air and gases
- self contained with integrated filtration and flow control
- compact, lightweight and easy to use
- with a range of -148°F to 68°F (or 3000 ppmv), the ceramic hygrometer probe responds to changes in moisture content, displaying it on the LED display and transmitting it remotely via a 4 to 20 mA signal
- completely contained within a rugged polycarbonate NEMA 4X enclosure
- unit is portable or can be easily wall mounted for permanent installations
- includes quick connect inlet and outlet connections for easy installation, an integral 0.3 micron filter, a flow meter and two programmable alarm relays
- applications include troubleshooting, air audits, performance validation and system calibration



nano-purification solutions  
charlotte, north carolina  
united states

nano-purification solutions  
new bethlehem, pennsylvania  
united states

nano-purification solutions  
st. catharines, ontario  
canada

nano-purification solutions  
gateshead, tyne and wear  
united kingdom

nano-purification solutions  
krefeld, germany

tel: 704.897.2182  
fax: 704.897.2183  
email: support@n-psi.com  
web: www.n-psi.com

## SPECIFICATIONS

specifications	
standard measurement range	-148°F to 68°F (-100°C to 20°C) or 3000 ppmv <sup>(1)</sup>
accuracy	± 3.6°F (± 2°C) of dew point
operating temperature range	23°F to 122°F (-5°C to 50°C)
storage temperature	-40°F to 167°F (-40°C to 75°C)
output	4-20 mA (maximum load resistance 500 Ω)
alarm	2 volt free contacts (3 A @ 240V)
user interface	front panel configuration of alarm points
display	4 digit ¾" (20 mm) red LED
power supply	85 to 265 VAC, 50 or 60 Hz
ingress protection	NEMA 4X (IP65)
power cord	6.5 ft (2 m) power cord provided
maximum pressure	145 psig (1 MPa/10 barg) <sup>(2)</sup>
sample flow rate	2.1 to 10.5 scfh (1 to 5 L/min)
filtration	99.5% removal efficiency at 0.3 micron
connections	6 mm OD quick connect tube fittings
sensor guard	sintered HDPE
protective case	polycarbonate
internal tubing	PTFE
warranty	1 year

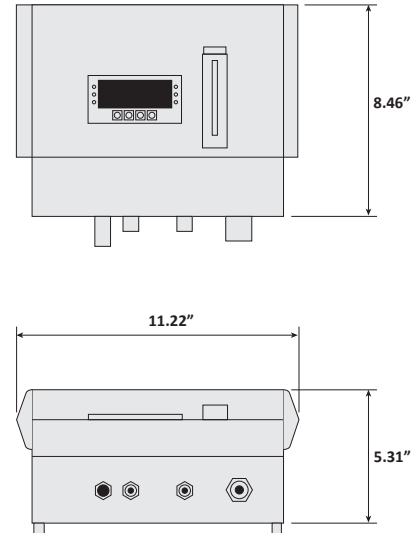

(1) choice of dew point or ppmv must be specified at time of orde. Non standard dew point ranges available on request  
 (2) higher pressure options available on request  
 (3) technical specifications subject to change without notice. Direct inquiries to support@n-psi.com or contact 704.897.2182