

GEN₂MINI Nitrogen Gas Generators

Features

- Ultra compact design and wide range of flow rates, make it the perfect generator for a variety of lower flow nitrogen applications.
- Significant cost savings over cylinder or liquid supply provides a typical return on investment of less than 24 months.
- Uses pressure swing adsorption to produce a continuous, uninterrupted supply of 95 to 99.999% purity nitrogen gas from clean, dry compressed air.
- 100% functional tested with 2 year warranty.
- Eliminates safety concerns associated with transporting and storing pressurised gas cylinders or liquid nitrogen.
- Reduces carbon footprint by eliminating gas delivery with positive impacts on sustainability targets.
- **eco-mode** energy savings control reduces energy consumption during periods of low demand.
- Optional integrated O₂ analyser and dew point sensors (N₂ or inlet air).



PLC Controlled Operation



Operated by a reliable PLC or advanced HMI interface. (optional HMI controller shown)

Easy to Maintain

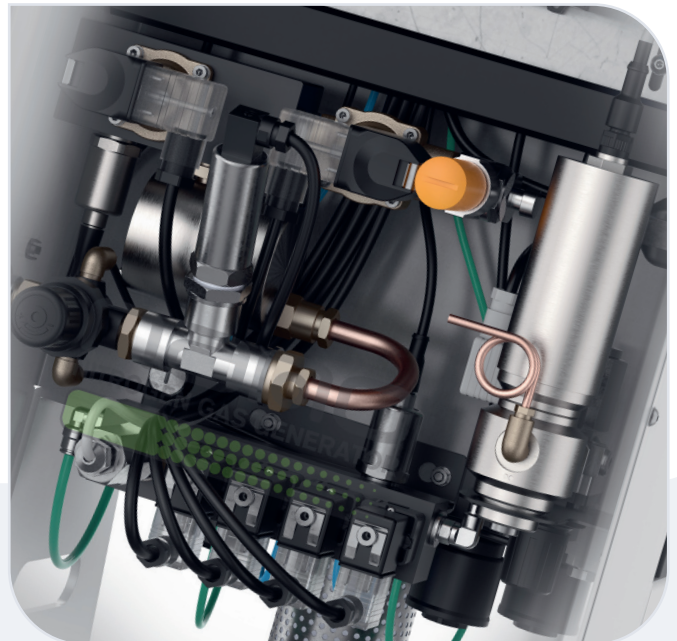

Robust piston valves significantly reduce maintenance schedules and minimise downtime.

nano N₂: Low Flow Nitrogen Gas Generators

MODEL	RATED OUTLET FLOW ⁽¹⁾	NITROGEN PURITY AT THE OUTLET (MAXIMUM OXYGEN CONTENT)											DIMENSIONS (mm)			APPROX. WEIGHT
		10 PPM	50 PPM	100 PPM	500 PPM	1000 PPM	0.5%	1%	2%	3%	4%	5%	A	B	C	kg
GEN2MINI-060	Nm ³ /h	-	-	-	0.6	0.8	1.7	2.1	2.8	3.4	3.9	4.3	738	440	453	54
GEN2MINI-080	Nm ³ /h	0.3	0.8	1.0	1.3	1.7	2.8	3.7	4.7	5.5	6.3	6.9	918	440	453	63
GEN2MINI-100	Nm ³ /h	0.5	1.3	1.5	2.2	2.5	4.2	5.3	6.8	7.8	8.7	9.6	1093	440	453	76
GEN2MINI-110	Nm ³ /h	0.8	1.4	1.7	2.7	3.2	5.2	6.4	7.8	8.8	10.1	11.1	1243	440	453	83
GEN2MINI-120	Nm ³ /h	1.6	2.2	2.5	3.7	4.3	6.2	8.0	10.1	11.7	13.0	14.3	1493	440	453	96
GEN2MINI-130	Nm ³ /h	1.8	3.0	3.4	4.7	5.5	7.9	9.9	12.2	14.1	17.2	18.8	1843	440	453	113

SPECIFICATIONS	STANDARD
Recommended inlet air ISO (ISO class)	ISO Class 2.2.1
Minimum inlet air quality (ISO class)	ISO Class 2:4:1
Minimum operating pressure (barg)	6
Maximum operating pressure (barg)	10
Recommended operating temperature range (°C)	20 - 25
Minimum/maximum operating temperature range (°C)	5 - 50
Supply voltage	100 - 240V AC
Fuse rating	3A 'T'
Frequency (Hz)	50 - 60
Maximum power consumption (W)	72
IP rating	IP53 (NEMA 2)

PRESSURE CORRECTION FACTORS ⁽²⁾					
Inlet pressure (barg)	6	7	8	9	10
Correction factor	0.88	1.00	1.10	1.20	1.30

TEMPERATURE CORRECTION FACTORS ⁽²⁾										
Inlet temperature (°C)	5	10	15	20	25	30	35	40	45	50
Correction factor	0.80	0.90	0.94	1.00	1.00	0.98	0.95	0.90	0.85	0.72

(1) At 7 barg and 25°C inlet conditions. For flow at other conditions contact nano.

(2) To be used as rough guide only. All applications should be confirmed by nano. Contact sales_uk@nano-purification.com.

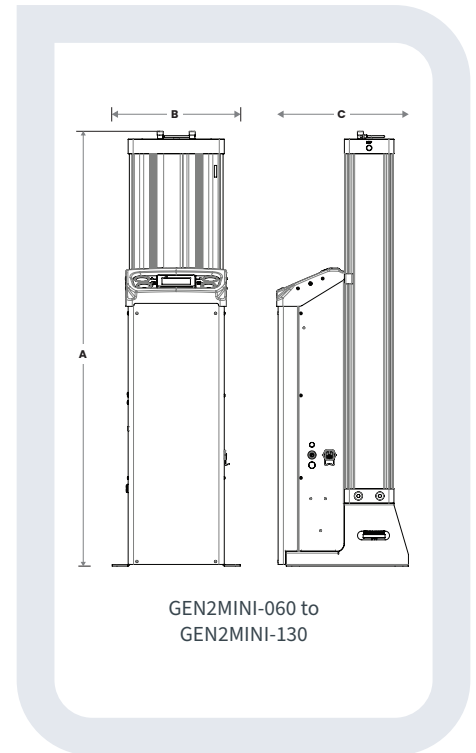

Technical specifications subject to change without notice.
Publication Reference: GEN_MINI-UK-EN-Version-001
©2024 Air & Gas Solutions LLC

nano
Experience. Customer. Service.

nano-purification solutions
www.nano-purification.com

United Kingdom
Gateshead, United Kingdom
Phone: +44 (0) 191 497 7700
Email: sales_uk@nano-purification.com

United States | Canada | United Kingdom | Germany | Singapore