

NBA 3120

324 scfm inlet / 243 scfm outlet breathing air purifier

nano NBA modular breathing air purification systems use the latest technology to provide clean, reliable and safe breathing air that meets or exceeds international standards. The NBA range are based on the tested and proven nano D^{1|2|3} modular dryers but employ a unique split cartridge system to completely treat air prior to respiration. While many systems only remove particulate, oil, odor and taste, the NBA range also removes carbon monoxide (CO) and scrubs carbon dioxide (CO₂) levels to exceed the most stringent standards.

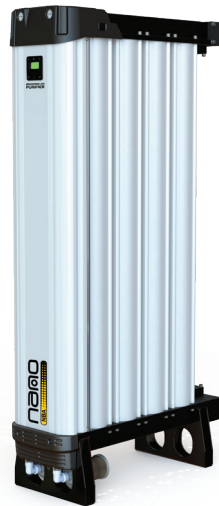

general characteristics	
inlet rated capacity (scfm) ⁽¹⁾	324
outlet rated capacity (scfm) ⁽¹⁾	243
absorbed power (kW)	0.0360
power supply (V/Ph/Hz) ⁽²⁾	100-240 VAC / 50 or 60 Hz
operating limits	
design operating pressure range (psig)	87 to 145
recommended operating temperature range (°F)	50 to 86
minimum design inlet temperature (°F)	35
maximum design inlet temperature (°F)	122
desiccant chambers	
4-layer mixed bed cartridge type	activated alumina, molecular sieve, activated carbon & catalyst
replacement cartridge (part no)	NBA SK 120 - quantity 3
filtration	
0.01 micron pre filter	NF 0700 M01
1.0 micron pre filter	NF 0700 M1
1.0 micron after filter	integrated
controls/design	
dryer design	PSA
controller type	PLC
NEMA rating	NEMA 1
air circuit	
inlet air circuit connections (NPT (F))	2" - quantity 1
outlet air circuit connections (NPT (F))	2" - quantity 1
meets or exceeds breathing air specification	
United States	CGA7.1 OSHA Grade D
Canada	CSA Z180.1-13
UK & Europe	EN12021

features

- c-ETL-US certification
- includes separate F1 M01 and M1 grade high-efficiency coalescing filters (shipped loose) and a built in 1 micron after filter
- patented combined filter & desiccant cartridge
- robust modular compact aluminum design
- reliable high-performance valves
- tower pressure gauges
- tower equalization for constant flow and pressure
- designed for tough industrial settings
- integrated compressor synchronization function
- supplied with separate CO monitor with visual and audible alarms (shipped loose)
- 4-layer mixed bed cartridge removes CO and scrubs CO₂
- energy saving dew point control (optional)

(1) flows based on 100 psig and 86°F inlet temperature. For all other conditions, contact support@n-psi.com
 (2) optional 24 V DC

nano-purification solutions
 charlotte, north carolina
 united states

nano-purification solutions
 new bethlehem, pennsylvania
 united states

nano-purification solutions
 st. catharines, ontario
 canada

nano-purification solutions
 gateshead, tyne and wear
 united kingdom

nano-purification solutions
 krefeld, germany

tel: 704.897.2182
 fax: 704.897.2183
 email: support@n-psi.com
 web: www.n-psi.com

technical specification

advanced PLC features

- digital interface
- digital LED display
- outlet air dew point indication (with ES option)
- user programmable operating parameters
- alarm indication

dimensions & weight

length ins (mm)	15.75 (400)
depth ins (mm)	31.1 (787)
height ins (mm)	60.6 (1538)
weight lbs (kgs)	661 (300)

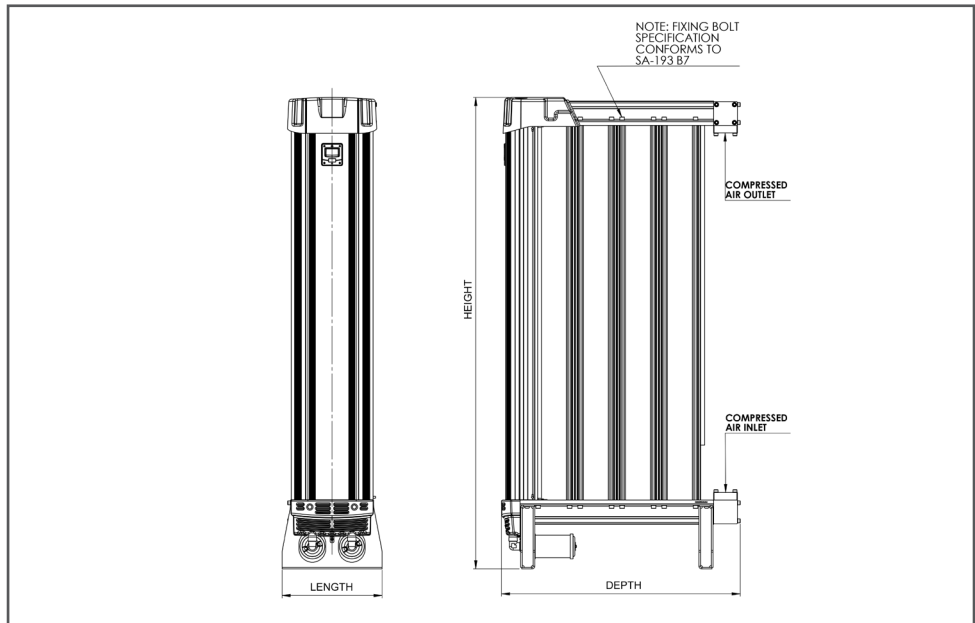

experience