

BPA 500

460VAC/60Hz -500 scfm desiccant air dryer

The nano D⁵ twin tower blower purge desiccant air dryer provides clean dry air for a wide range of industrial applications. These dryers use a blower and an external heater to provide heated ambient air for regeneration. With purge air usage less than 2% (averaged over cycle) and a zero purge option, these dryers offer the lowest cost of operation for most applications.



general characteristics

rated capacity (scfm)*	500
regeneration air (scfm)*	25
absorbed power (kW)	12.1
power supply (V/Ph/Hz)	460 VAC / 60 Hz

operating limits

minimum/design/maximum operating pressure range (psig)	80 / 100 / 150
minimum/design/maximum ambient temperature range (°F)	38 / 100 / 120
minimum/design/maximum inlet temperature (°F)	38 / 100 / 120

desiccant chambers

desiccant type	activated alumina
desiccant weight (lbs)	700

controls/design

dryer design	PSA externally heated blower purge dryer
controller type	PLC
NEMA rating	NEMA 4

heater

absorbed power (kW)	10
---------------------	----

blower

absorbed power (hp)	2.75
---------------------	------

air circuit

air circuit connections (NPT(F))	2"
----------------------------------	----

ISO class

ISO air quality class (water content)	class 2 (-40°F pdp)
---------------------------------------	---------------------

*in compliance with CAGI (ADF 100) / NFPA (class H): inlet temperature 100°F, ambient temperature 100°F, inlet pressure 100 psig, pressure dew point -40°F. For all other conditions, contact support@n-psi.com

features

- UL/cUL compliant
- ASME coded pressure vessels
- visual moisture indicator
- integral energy saving outlet dew point control (optional)
- pre- and after filters recommended
- variety of options including bypass and pre-packaged systems
- high-performance butterfly valves made in USA

electrical features

- PLC controller
- fiberglass cUL control panel for NEMA 4X protection class
- ETL approved electrical panel
- four-hour timed NEMA cycle with thermocouple heater override to prevent overheating in periods of low demand
- two contactors to prevent runaway heater

nano-purification solutions llc
charlotte, north carolina
united states

nano-purification solutions penn
new bethlehem, pennsylvania
united states

nano-purification solutions
st. catharines, ontario
canada

nano-purification solutions ltd
gateshead, tyne and wear
united kingdom

nano-purification solutions GmbH
krefeld, germany

tel: 704.897.2182
fax: 704.897.2183
email: support@n-psi.com
web: www.n-psi.com

technical specification

dimensions & weight

length in (mm)	50 (1270)
depth in (mm)	60 (1524)
height in (mm)	87.4 (2220)
weight lbs (kgs)*	2750 (1247)

*does not include desiccant

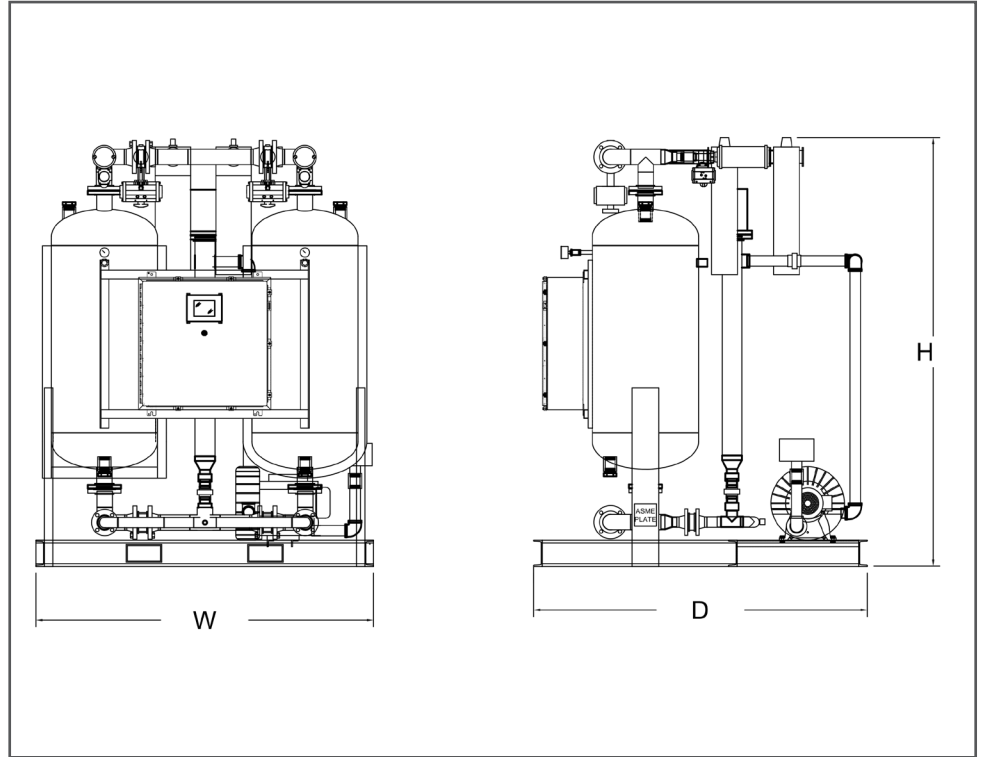

experience