

## MEL 1500

1500 scfm mist eliminator

Exceptional performance, reliability and durability with a low operating cost are all essential in a compressed air system. The nano F<sup>6</sup> MEL range of mist eliminators delivers all this and more. With a service life of over 10 years and an initial pressure drop of less than 0.5 psig, utility-rebate friendly MEL provides the most economic value on the market for general purpose protection.



### general characteristics

rated capacity (scfm)*	1500
------------------------	------

### operating limits

recommended operating temperature range (°F)	60 - 180
--	----------

design operating temperature range (°F)	35 - 248
---	----------

design operating pressure range (psig)	20 - 150
--	----------

### filtration

initial differential pressure (psig)	less than 0.5
--------------------------------------	---------------

recommended pressure differential for element change (psid)	1.0
---	-----

filtration performance	0.3 micron @ 99.97% efficiency
------------------------	--------------------------------

### air circuit

air circuit connections NPT(F)	4" Flg
--------------------------------	--------

ISO class	2.7.3
-----------	-------

\*at 100 psig. For all other conditions, contact support@n-psi.com

### features

- differential pressure gauge kit supplied as standard for on-site installation
- heavy duty pressure vessel built in accordance with latest edition of section VIII Div 1 ASME Code
- long service life of 10 + years
- external powder coated as standard; optional interior powder epoxy coating for corrosive environments
- pleated glass fiber coalescing media is 99.97% efficient with particle removal down to 0.3 micron including coalesced liquid water and oil
- element is reinforced with epoxy coated steel wire and epoxy potting compound with perforated metal core for additional support and protection
- pleated media has a far greater surface area for filtration, providing lower pressure drop when compared to a conventional wrapped element
- energy efficient units are utility rebate-friendly
- serviceability without inlet & outlet pipe disruption
- automatic drain vent ports and safety valve port included as standard

**nano-purification solutions llc**  
charlotte, north carolina,  
united states

**nano-purification solutions**  
st. catharines, ontario,  
canada

**nano-purification solutions ltd**  
gateshead, tyne and wear,  
united kingdom

tel: 704.897.2182  
fax: 704.897.2183  
email: support@n-psi.com  
web: www.n-psi.com

## technical specification

### dimensions & weight

width (ins)	28.0
height (ins)	71.0
minimum clearance for element change (ins)	22.5
weight (lbs)	662

## product overview

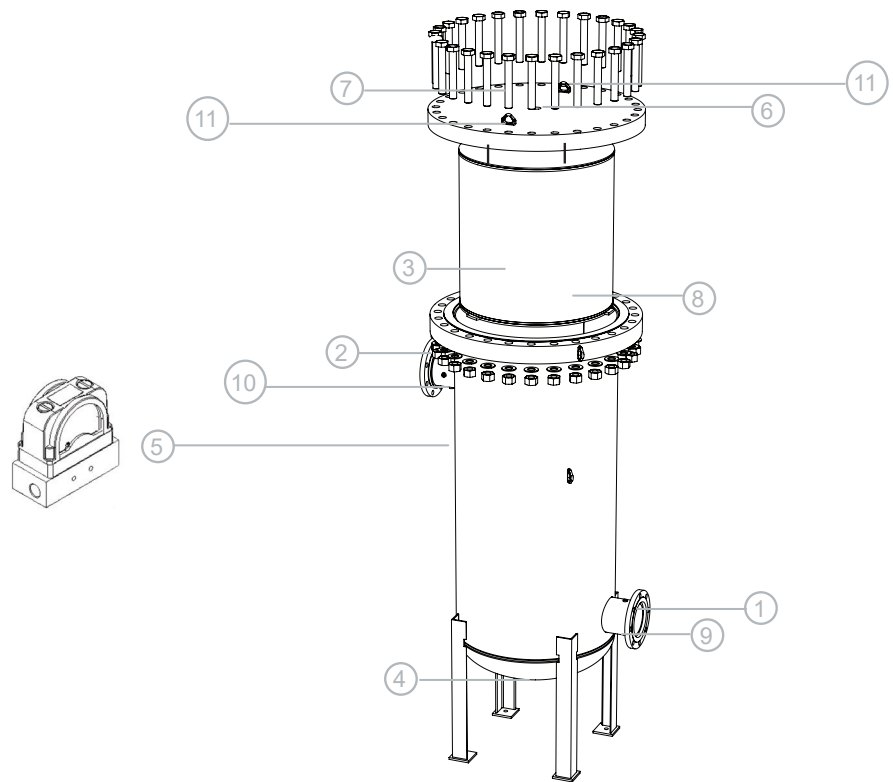

number	description	number	description
1	compressed air inlet	7	blind flange
2	compressed air outlet	8	element removal
3	element	9	inlet automatic drain port
4	drain port	10	automatic drain vent port
5	differential pressure indicator	11	lifting lugs
6	safety relief valve port		