



nano D^{1|2|3}: Modular Desiccant Air Dryers

NDL 130 GFN

100-240 VAC/50 or 60 Hz – 177 scfm Desiccant Air Dryer

The nano D² modular air dryer provides clean dry air for a wide range of industrial applications. These dryers use the pressure swing adsorption principle in a modular design to dehydrate and purify your compressed air in a simple, efficient and compact package. With digital PLC controls that manage energy consumption and provide dew point monitoring, the D² modular desiccant air dryer provides substantial energy savings under various seasonal conditions for critical applications.



GENERAL CHARACTERISTICS	
Rated capacity (scfm) ⁽¹⁾	177
Regeneration air (scfm)	35.4
Absorbed power (kW)	0.0360
Power supply (V/Ph/Hz) ⁽²⁾	100 to 240 /50 or 60
OPERATING LIMITS	
Design operating pressure range (psig)	58 to 232
Design operating temperature range (°F)	35 to 100
Minimum/maximum ambient temperature (°F)	35 to 122
Maximum inlet temperature (°F)	122
DESICCANT CHAMBERS	
Desiccant type	activated alumina
Desiccant cartridges with integrated afterfilter (kit no)	NDK 130
CONTROLS/ DESIGN	
Dryer design	PSA
Controller type (PLC)	programmable logic controller
NEMA rating	NEMA 1
AIR CIRCUIT	
Air circuit connections (NPT)	1"
ISO CLASS	
ISO air quality class (water content)	class 2 (-40°F pdp)

(1) In compliance with CAGI (ADF 100) / NFPA (class H): inlet temperature 100°F, ambient temperature 100°F, inlet pressure 100 psig, pressure dew point -40°F (-94°F optional). For all other conditions, contact support@airandgassolutions.com.

(2) Optional 24 V DC

Dimensions & Weight

DIMENSIONS AND WEIGHT	
A (ins)	72.7
B (ins)	16.8
C (ins)	11.1
Weight (lbs)	247

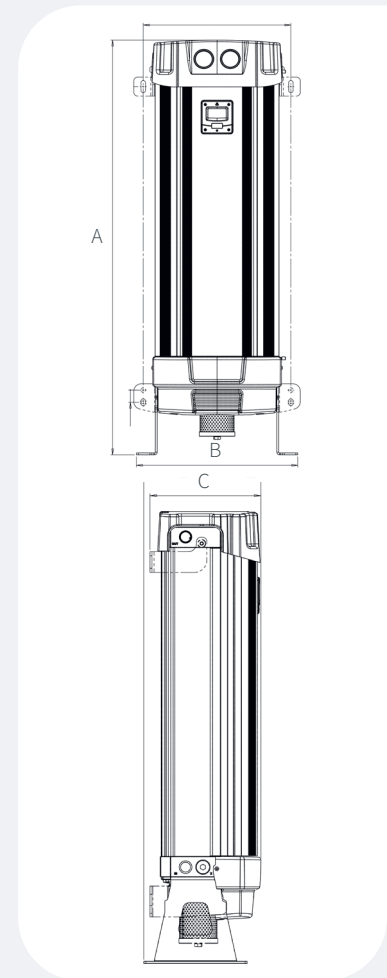

nano D¹¹²¹³: Modular Desiccant Air Dryers

Features

- C-ETL-US certification
- Includes a separate GFN M01 grade prefilter (shipped loose) and a built in 1 micron afterfilter.
- Patented combined filter & desiccant cartridge; no afterfilter required
- Advanced PLC controlled operation
- Built in reliability with a 2-year warranty
- Energy saving (ES) dew point control (optional)
- Floor or wall mounted (optional wall mounting brackets available) installation
- Reliable high-performance valves
- Tower pressure gauges
- Tower equalization for constant flow and pressure
- Designed for tough industrial settings.
- Integrated compressor synchronization function
- Alarm indication

Advanced PLC Features

- Energy-aware control with PDP switching (Optional sensor)
- Continuous pressure and temperature monitoring
- Clear alarms, event logs, and guided diagnostics
- Intuitive HMI with quick start/stop
- Modbus TCP connectivity
- Industrial protection (up to IP65/NEMA 4, panel-mounted with gasket)
- Drop-in retrofit or factory-fit
- Service-friendly wiring harness
- Audit-ready data logging
- Interoperability with companion equipment

Technical specifications subject to change without notice.
Publication Reference: NDL130-US-EN-Version-000
©2026 Air & Gas Solutions LLC



nano

Experience. Customer. Service.

nano-purification solutions
www.nano-purification.com

United States
Charlotte, North Carolina
Phone: +1 704 897 2182
Email: support@airandgassolutions.com

United States | Canada | United Kingdom | Singapore