

MODEL	PORT SIZES	DIMENSION MM (INCHES)	WEIGHT
	BSPP (NPT)	A	KG (LBS)
NDM-060-PNU	G1" (1")	734.75 (29)	40 (88)
NDM-070-PNU		915.50 (36)	54 (119)
NDM-080-PNU		1090.50 (43)	64 (141)
NDM-090-PNU		1240.50 (59)	76 (167)
NDM-100-PNU		1489.40 (49)	91 (200)
NDM-110-PNU		1839.75 (72)	112 (247)
NDM-120-PNU			
NDM-130-PNU			

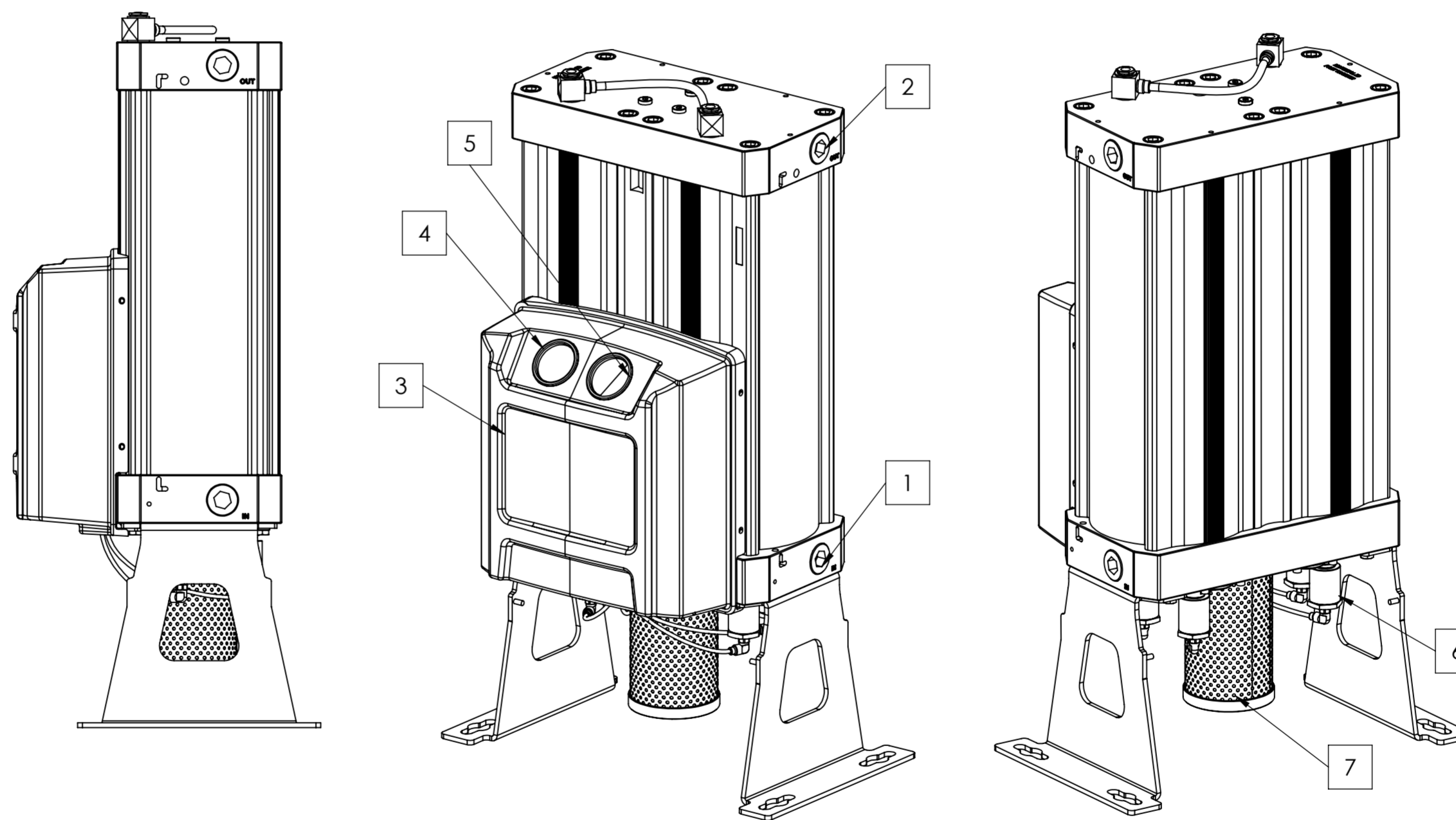

SPECIFICATION	
ISO 8573 - 1: 2001 QUALITY CLASSES	CLASS 2: DIRT: 1µ CLASS 2: WATER: -40°C (-40°F) PDP
MINIMUM WORKING PRESSURE	6 barg (87 psig)
MAXIMUM WORKING PRESSURE	16 barg (232 psig)
MINIMUM INLET TEMPERATURE	+1.5°C (35°F)
MAXIMUM INLET TEMPERATURE	50°C (122°F)

ITEM NUMBER	ITEM DESCRIPTION
1	COMPRESSED AIR INLET
2	COMPRESSE AIR OUTLET
3	CONTROL BOX
4	COLUMN 'A' PRESSURE GAUGE
5	COLUMN 'B' PRESSURE GAUGE
6	PILOT VALVE [x4]
7	EXHAUST SILENCER

REVISIONS		
REV.	DESCRIPTION	DATE
C-00	INITIAL REVISION	28/09/2022

NOTES:
SEE SPECIFICATION TABLE

GENERAL TOLERANCES UNLESS OTHERWISE STATED:
X ± 0.5mm | X.X ± 0.25mm | X.XX ± 0.1mm
ANGLES ± 0.5°

	DRAWN	CHECKED	APPROVED
NAME	CK	IC	JP
DATE	22/9/22	22/9/22	22/9/22

nano-purification solutions limited
www.n-psi.co.uk 

© NANO-PURIFICATION SOLUTIONS LTD 2022.
THE ORIGINAL OF THIS DRAWING IS COPYRIGHT AND CONTAINS CONFIDENTIAL INFORMATION.
IT IS THE PROPERTY OF NANO-PURIFICATION SOLUTIONS LTD. WITHOUT PERMISSION IT MAY NOT
BE COPIED, SHOWN OR HANDLED TO A THIRD PARTY OR OTHERWISE USED AND IT IS TO BE RETURNED
PROMPTLY UPON REQUEST TO NANO-PURIFICATION SOLUTIONS LTD.

MATERIAL: SEE DETAILS WEIGHT (KG): SEE DETAILS
FINISH: SEE DETAILS

TITLE: SERIES 2 PNU COMPRESSED AIR DRYER

DWG NO. PD-0068	REVISION: C-00
SCALE - 1:5	SHEET 1 of 1 SHEET SIZE A2
DO NOT SCALE DRAWING	