

REVISIONS		
REV.	DESCRIPTION	DATE
C-01	INITIAL REVISION	28/09/2022

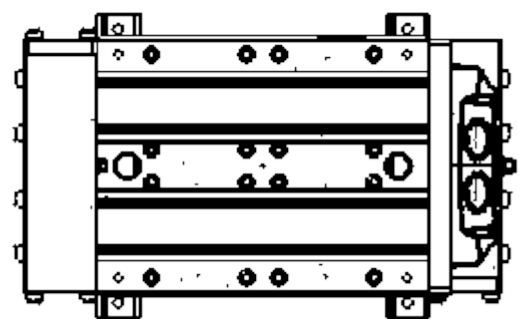

MODEL	CONNECTION		DIMENSION											APPROX. WEIGHT		SILENCER CORES	
			A		B		C		D		E		F				
			BSPP	NPT	HEIGHT		WIDTH		LENGTH		AIR OUTLET		AIR INLET		FLOOR MOUNTING		kg
NDM-2110 PNU	2"	2"	1249	49.1	400	15.7	659	25.6	1124	44.3	284	11.2	382	15.0	123	348	2
NDM-2120 PNU	2"	2"	1499	59.0					1374	54.1					134	394	2
NDM-2130 PNU	2"	2"	1849	72.8					1724	67.9					159	478	2
NDM-3130 PNU	2"	2"	1849	72.8			827	32.2	1724	67.9			550	21.7	208	652	2
NDM-4130 PNU	2.5"	2.5"	1849	72.8			991	38.8	1124	44.3			718	28.3	261	833	3
NDM-6120 PNU	2.5"	2.5"	1499	59.0			1327	52.1	1374	54.1			304	963	3		
NDM-6130 PNU	2.5"	2.5"	1849	72.8					1724	67.9			1054	41.5	367	1197	4

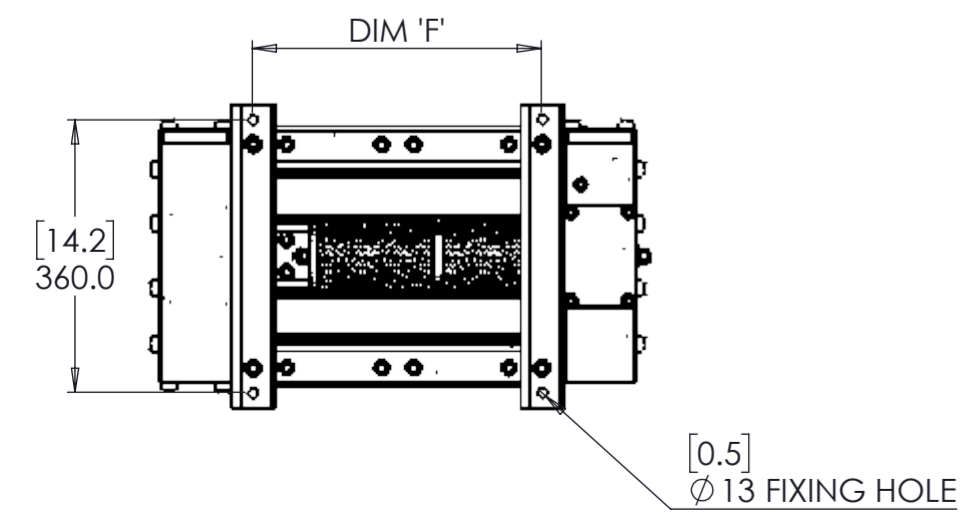
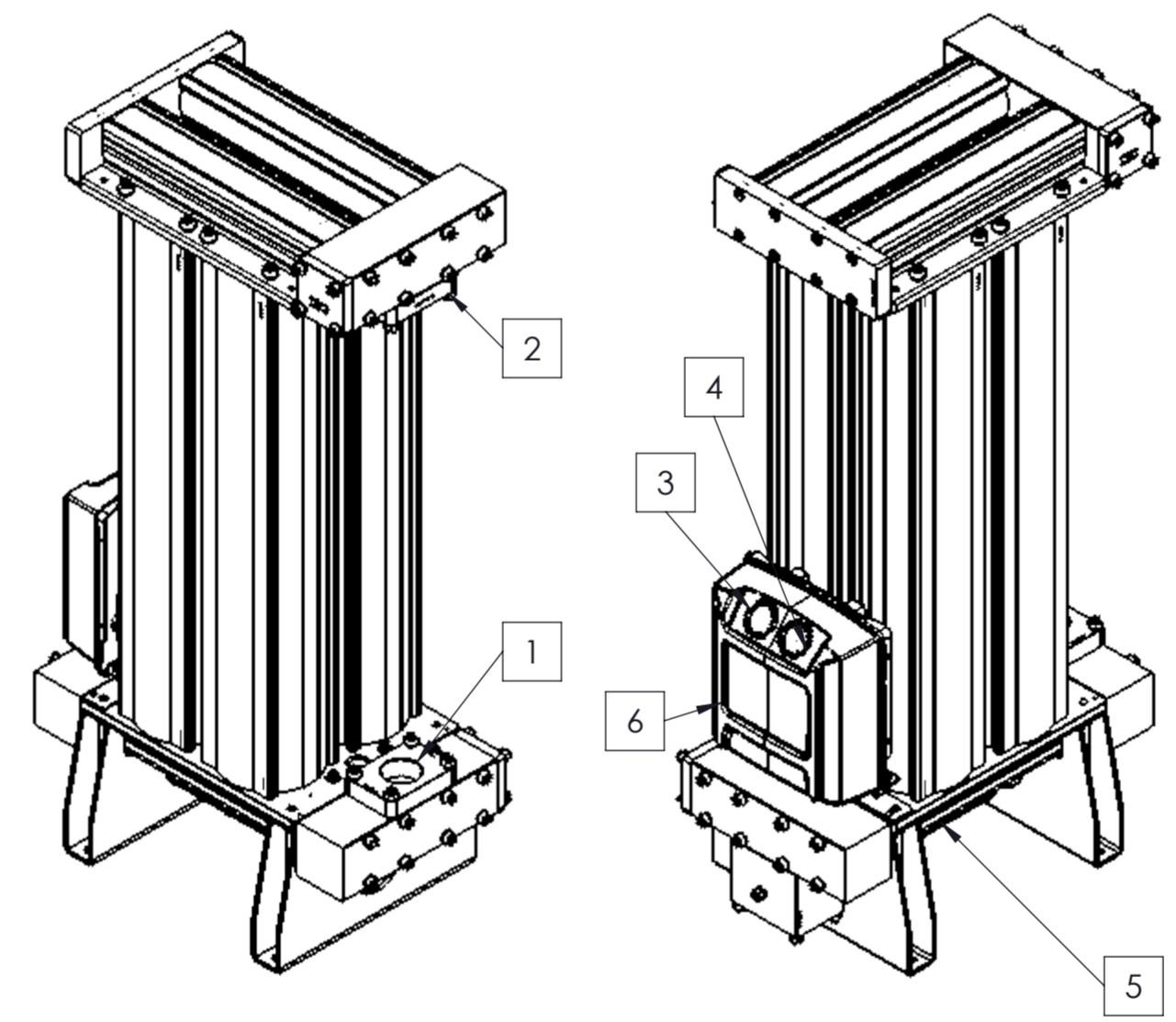
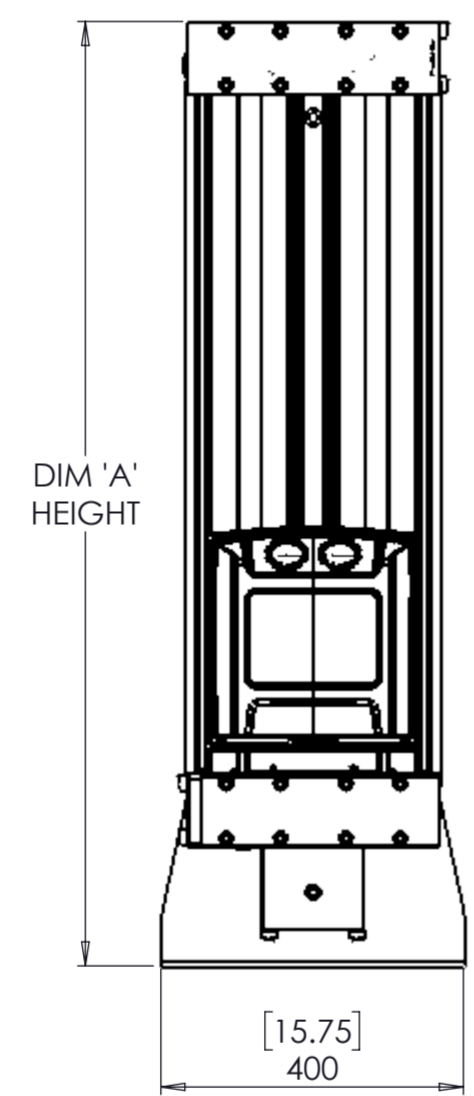
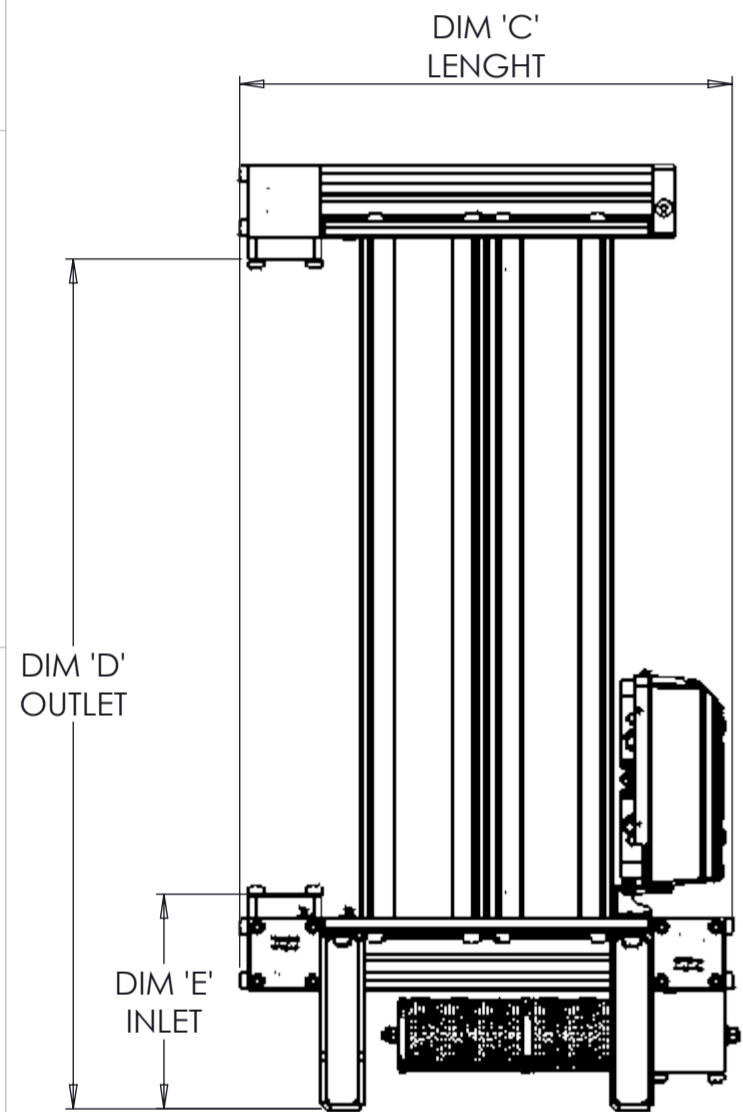

ITEM NUMBER	ITEM DESCRIPTION
1	COMPRESSED AIR INLET
2	COMPRESSED AIR OUTLET
3	COLUMN 'A' PRESSURE GUAGE
4	COLUMN 'B' PRESSURE GUAGE
5	EXHAUST SILENCER
6	CONTROL BOX

NOTES:

ISO 8573-1: 2001 QUALITY CLASSES
 CLASS 2: DIRT 1µ
 CLASS 2: WATER -40 C (-40 F) PDP

MINIMUM WORKING PRESSURE
 6 barg (87 psig)

MAXIMUM WORKING PRESSURE
 10 BARG (145 PSIG)

POWER SUPPLY
 N/A

MINIMUM INLET TEMPERATURE
 +1.5 C (35 F)

MAXIMUM INLET TEMPERATURE
 50 C (122 F)

GENERAL TOLERANCES UNLESS OTHERWISE STATED:
 X ± 0.5mm | X.X ± 0.25mm | X.XX ± 0.1mm
 ANGLES ± 0.5°

	DRAWN	CHECKED	APPROVED
NAME	CK	IC	JP
DATE	22/09/22	22/09/22	22/09/22

nano-purification solutions limited
www.n-psi.co.uk

© NANO-PURIFICATION SOLUTIONS LTD 2022.
 THE ORIGINAL OF THIS DRAWING IS COPYRIGHTED AND CONTAINS CONFIDENTIAL INFORMATION.
 IT IS THE PROPERTY OF NANO-PURIFICATION SOLUTIONS LTD WITHOUT WHOSE PERMISSION IT MAY NOT
 BE COPIED, SHOWN OR HANDLED TO A THIRD PARTY OR OTHERWISE USED AND IT IS TO BE RETURNED
 PROMPTLY UPON REQUEST TO NANO-PURIFICATION SOLUTIONS LTD.

MATERIAL:	SEE DETAILS	WEIGHT (KG):	SEE DETAILS
FINISH:	SEE DETAILS		

TITLE:
 SERIES 3 PNU COMPRESSED AIR DRYER

DWG NO. PD-0070	REVISION: C-01
SCALE - 1:10	SHEET 1 of 1
DO NOT SCALE DRAWING	SHEET SIZE A2