

ITEM NO	QTY	DESCRIPTION
1	2	DESICCANT VESSEL
2	2	INLET BUTTERFLY VALVE
3	2	PURGE EXHAUST BUTTERFLY VALVE
4	1	PURGE EXHAUST MUFFLER
5	2	OUTLET CHECK VALVE
6	2	HEATER OUTLET CHECK VALVE
7	2	VESSEL PRESSURE GAUGE
8	2	PRESSURE RELIEF VALVE
9	1	HEATER
10	1	PURGE ADJUSTMENT VALVE
11	1	PURGE PRESSURE GAUGE
12	1	ELECTRICAL ENCLOSURE
13	1	PRE-FILTER
14	1	AFTER FILTER
15	1	ZERO-LOSS DRAIN

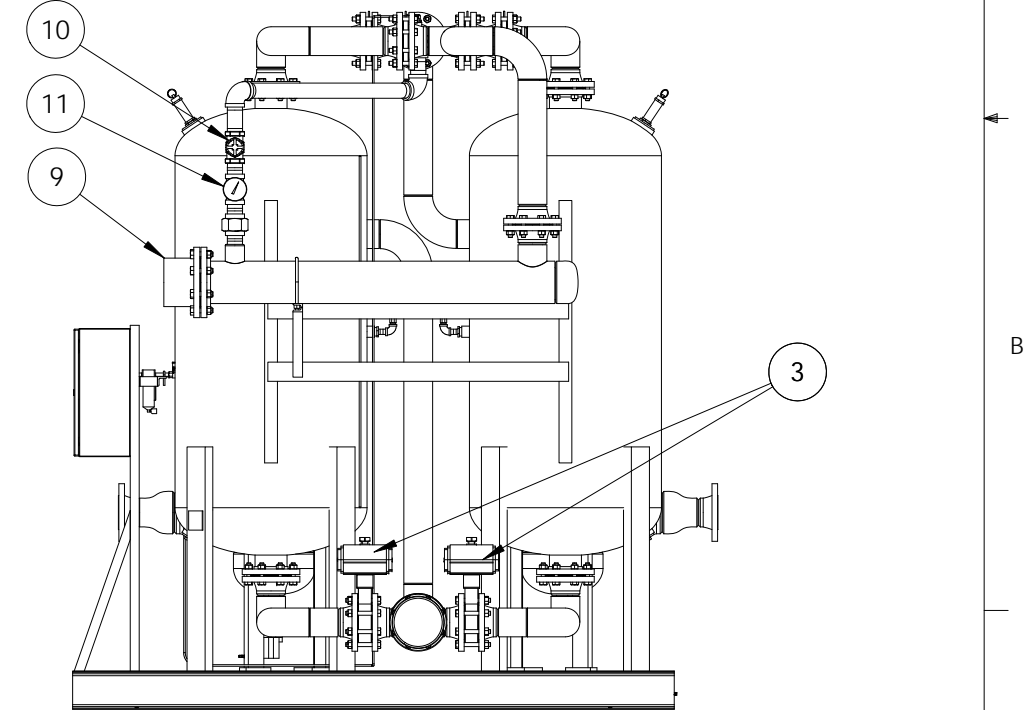
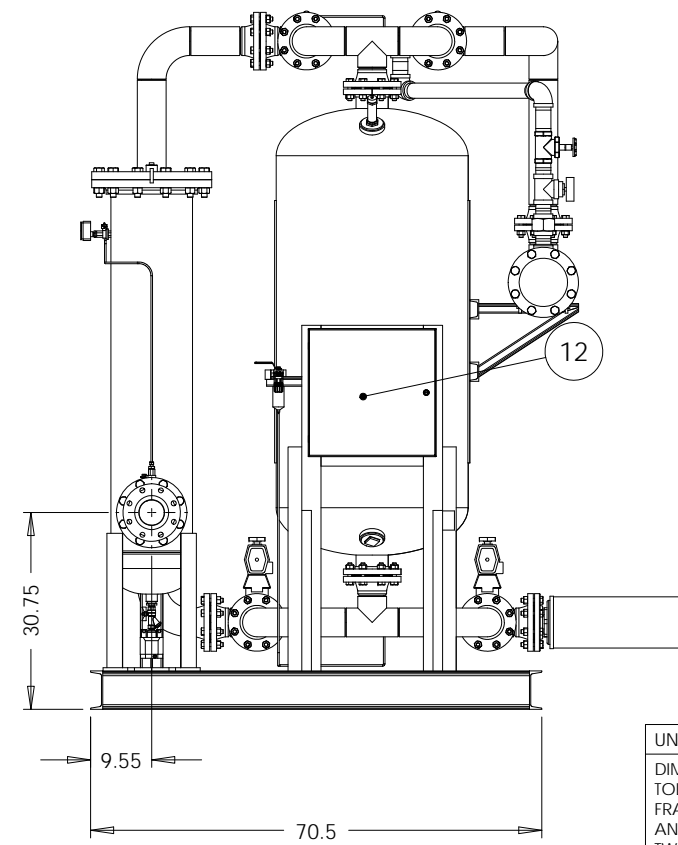
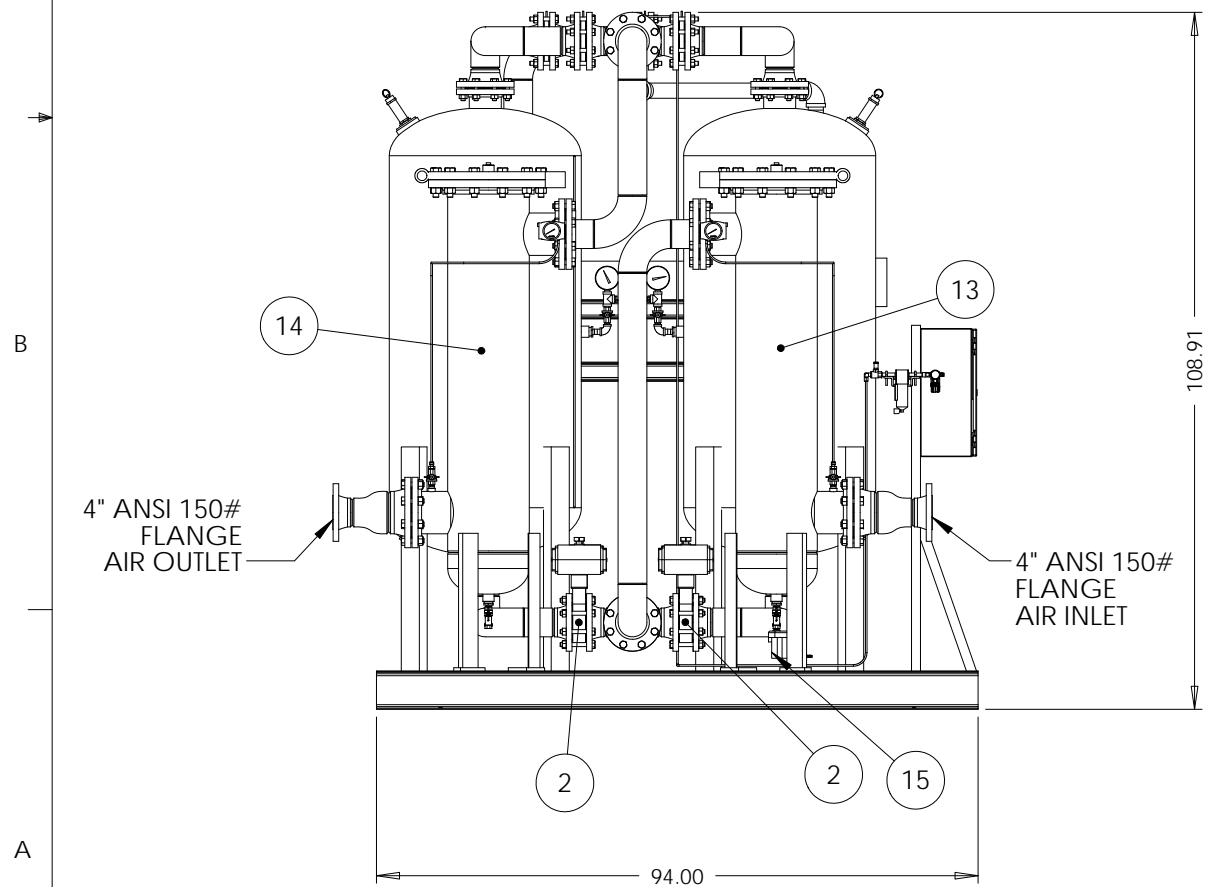

UNLESS OTHERWISE SPECIFIED:
 DIMENSIONS ARE IN INCHES
 TOLERANCES:
 FRACTIONAL ± 0.125
 ANGULAR: ± 0.5°
 TWO PLACE DECIMAL ± .03
 THREE PLACE DECIMAL ± .003

THIRD ANGLE PROJECTION

MATERIAL

FINISH

DO NOT SCALE DRAWING

	NAME	DATE
DRAWN	O.P.	09/30/13
CHECKED	M.S.	09/30/13
ENG APPR.		
MFG APPR.		
Q.A.		
COMMENTS:		

nano nano-purification solutions - TN
 323 crisp circle
 maryville, tn 37801
 P: (865) 681-7066

TITLE: DRYER, DESICC., AEHD-2500, PACK B, 1 PRE & 1 AFTER FILTER, 150 PSIG, 100 DEG F, T-30, REV 1

SIZE	DWG. NO.	REV
B	AG9935540-B	1

SCALE: 1:50 WEIGHT: SHEET 1 OF 1

PROPRIETARY AND CONFIDENTIAL
 THE INFORMATION CONTAINED IN THIS DRAWING IS THE SOLE PROPERTY OF NANO PURIFICATION SOLUTIONS ANY REPRODUCTION IN PART OR AS A WHOLE WITHOUT THE WRITTEN PERMISSION OF NANO PURIFICATION SOLUTIONS IS PROHIBITED.