

ITEM NO	QTY	DESCRIPTION
1	2	DESICCANT VESSEL
2	2	INLET BUTTERFLY VALVE
3	2	PURGE EXHAUST BUTTERFLY VALVE
4	2	OUTLET CHECK VALVE
5	2	HEATER OUTLET CHECK VALVE
6	2	VESSEL PRESSURE GAUGE
7	2	PRESSURE RELIEF VALVE
8	1	HEATER
9	1	PURGE ADJUSTMENT VALVE
10	1	PURGE PRESSURE GAUGE
11	1	ELECTRICAL ENCLOSURE
12	1	PRE-FILTER
13	1	AFTER FILTER
14	1	ZERO-LOSS DRAIN

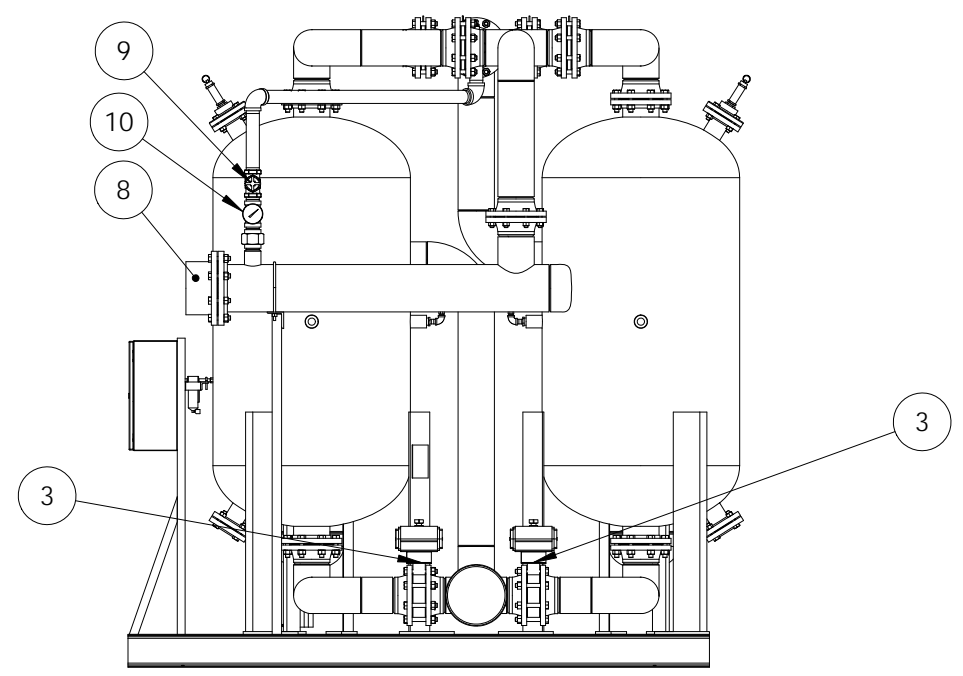
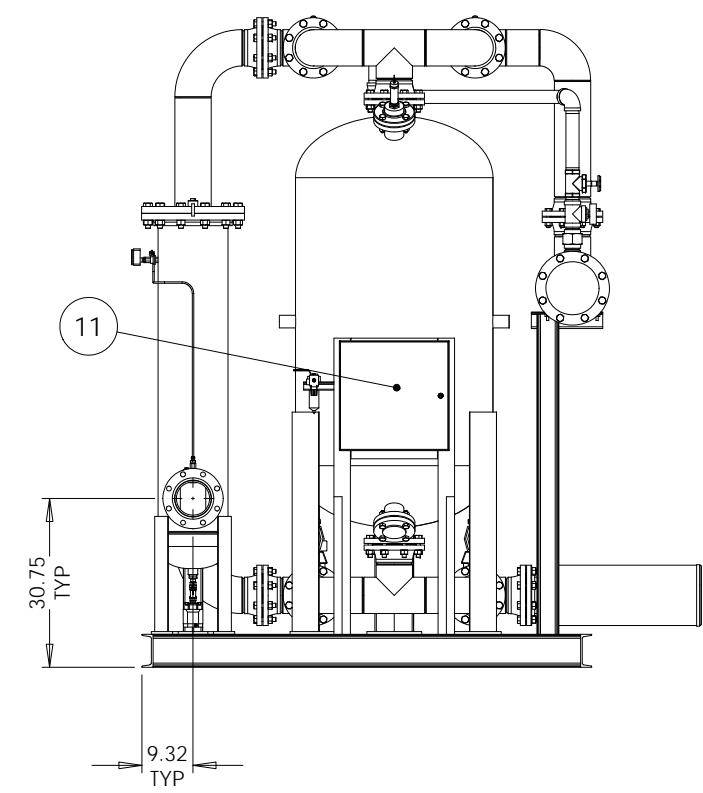
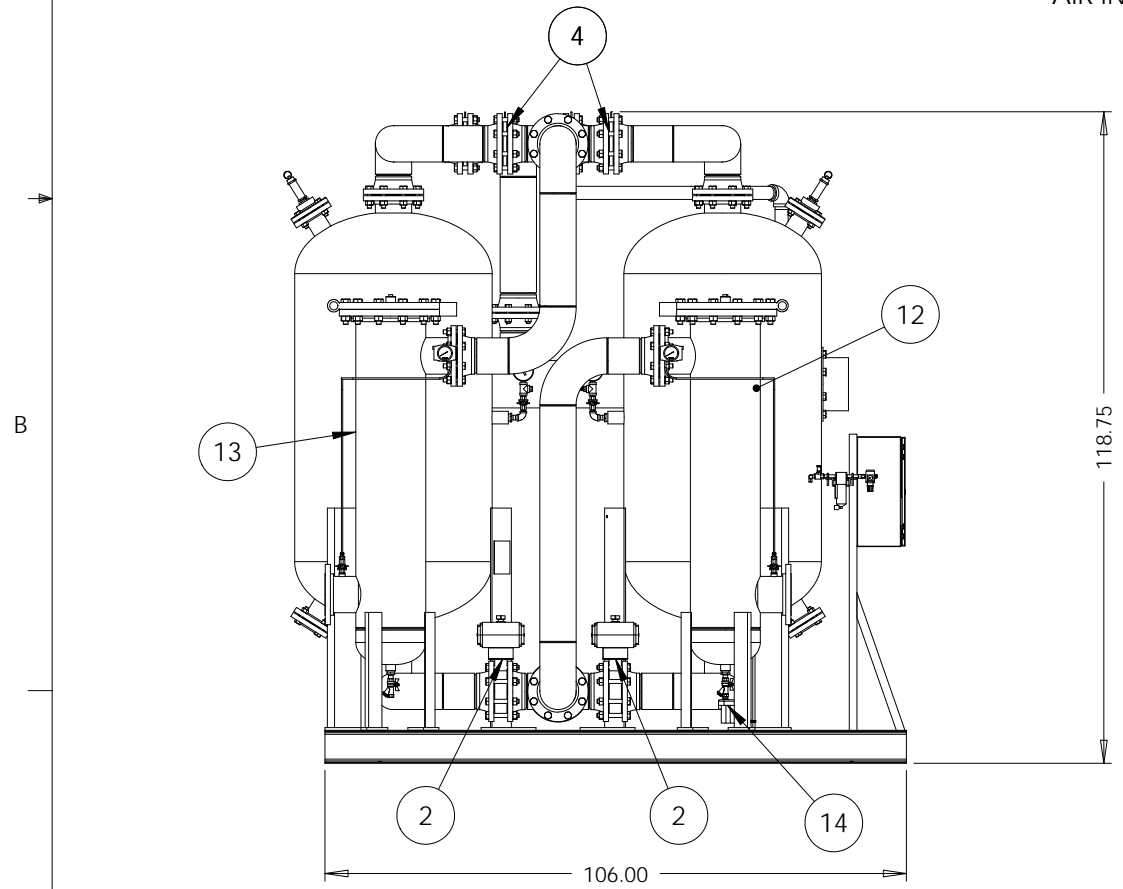

PROPRIETARY AND CONFIDENTIAL
 THE INFORMATION CONTAINED IN THIS DRAWING IS THE SOLE PROPERTY OF NANO PURIFICATION SOLUTIONS ANY REPRODUCTION IN PART OR AS A WHOLE WITHOUT THE WRITTEN PERMISSION OF NANO PURIFICATION SOLUTIONS IS PROHIBITED.

UNLESS OTHERWISE SPECIFIED:
 DIMENSIONS ARE IN INCHES
 TOLERANCES:
 FRACTIONAL ± 0.125
 ANGULAR: ±0.5°
 TWO PLACE DECIMAL ± .03
 THREE PLACE DECIMAL ± .003

THIRD ANGLE PROJECTION

MATERIAL

FINISH

DO NOT SCALE DRAWING

	NAME	DATE
DRAWN	O.P.	09/30/13
CHECKED	M.S.	09/30/13
ENG APPR.		
MFG APPR.		
Q.A.		
COMMENTS:		

nano nano-purification solutions - TN
 323 crisp circle
 maryville, tn 37801
 P: (865) 681-7066

TITLE: DRYER, DESICC., AEHD-3000, PACK B, 1 PRE & 1 AFTER FILTER, 150 PSIG, 100 DEG F, T-36, REV 1

SIZE B	DWG. NO. AG9935640-B	REV 1
SCALE: 1:50		WEIGHT:
		SHEET 1 OF 1