

DESCRIPTION	INLET FLOW RATE m3/hr (scfm)	INLET/OUTLET PIPE SIZE MM (INCHES)	DIMENSION 'A'	DIMENSION 'B'	DIMENSION 'C'	MOUNTING HOLES	APPROX WEIGHT kg (lbs)
<b>NDL-010</b>	5.1 (3)	8mm (3/8") PUSH-IN	440 (17.3)	264 (10.4)	222 (8.7)	156 (6.1)	9 (19.8)
<b>NDL-020</b>	8.5 (5)	8mm (3/8") PUSH-IN	440 (17.3)				9 (19.8)
<b>NDL-030</b>	17 (10)	8mm (3/8") PUSH-IN	650 (25.6)				13.5 (29.8)
<b>NDL-040</b>	25.5 (15)	8mm (3/8") PUSH-IN	890 (35.0)	330 (13.0)	276 (10.9)	276 (10.9)	18.5 (40.8)
<b>NDL-050</b>	34 (20)	12mm (1/2") PUSH-IN	1190 (46.8)				25.5 (56.2)

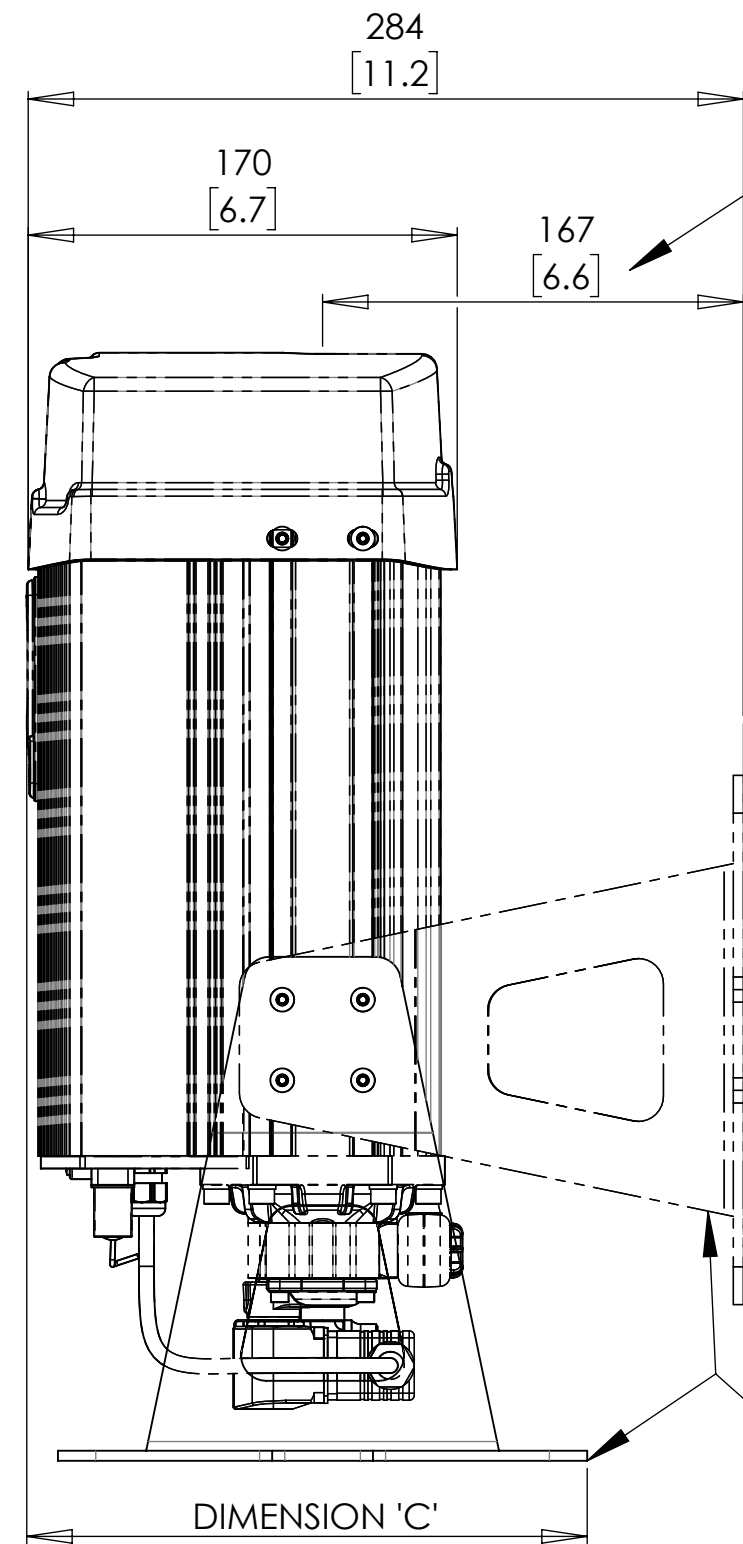

DIMENSION TO CENTRE OF INLET & OUTLET

STANDARD BRACKETS ALLOW BOTH FLOOR AND WALL MOUNTING

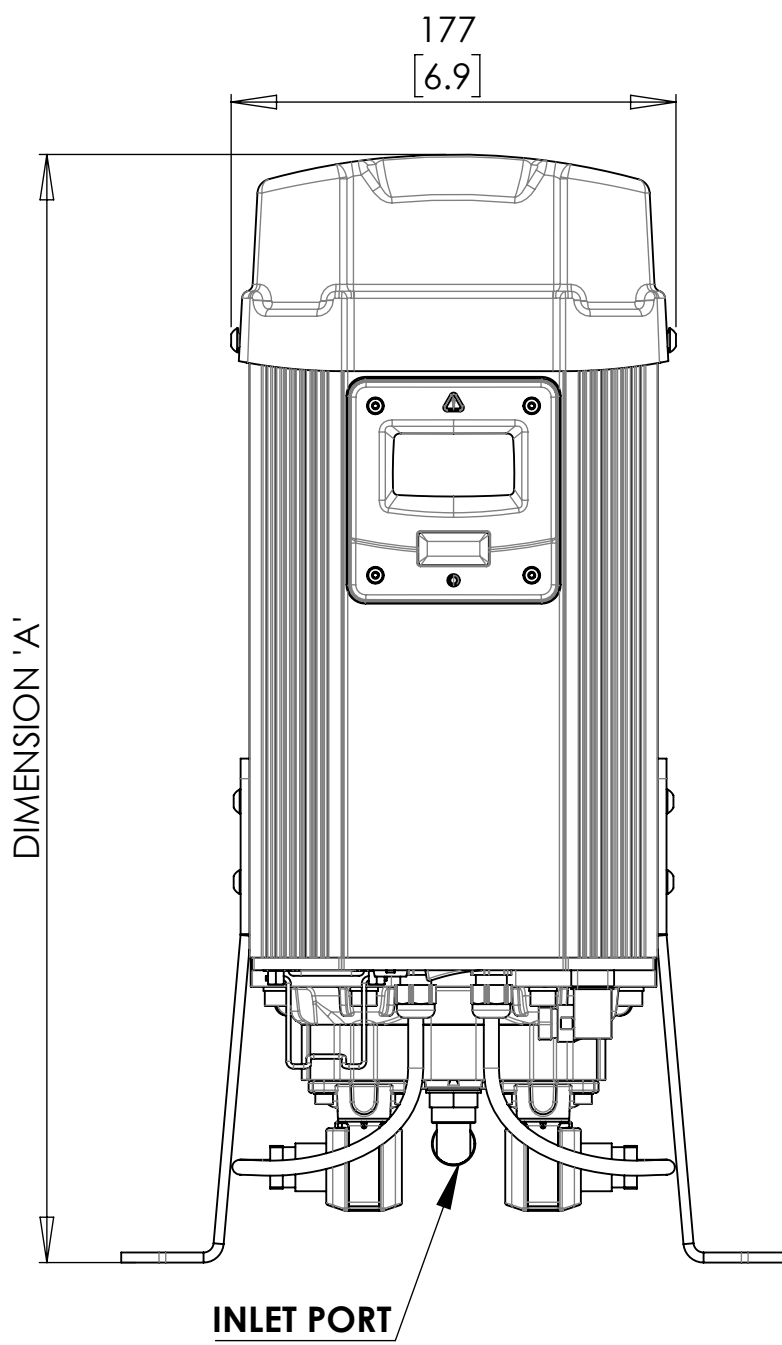
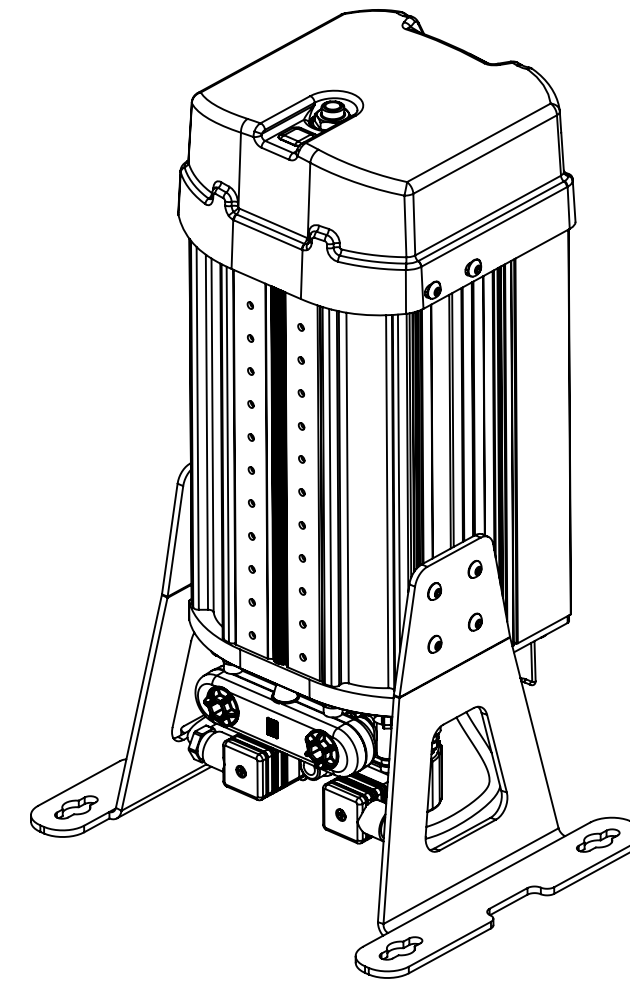

**PICTORIAL VIEWS**

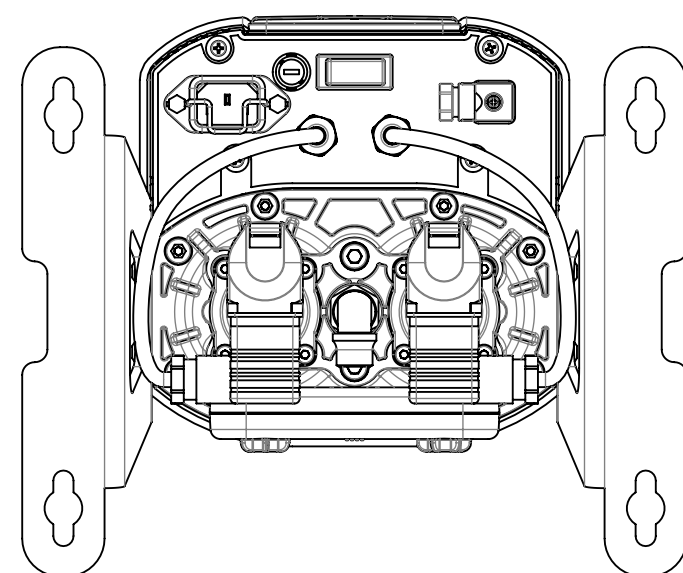

SPECIFICATION	EUROPEAN & NORTH AMERICAN	CANADIAN (CRN)
<b>ISO 8573 - 1: 2001 QUALITY CLASSES</b>	CLASS 2: DIRT: 1µ CLASS 2: WATER: -40°C (-40°F) PDP	CLASS 2: DIRT: 1µ CLASS 2: WATER: -40°C (-40°F) PDP
<b>MINIMUM WORKING PRESSURE</b>	4 barg (58 psig)	4 barg (58 psig)
<b>MAXIMUM WORKING PRESSURE</b>	16 barg (232 psig)	7 barg (101 psig)
<b>POWER SUPPLY</b>	110 - 240V AC / 50-60 Hz	110 - 240V AC / 50-60 Hz
<b>MINIMUM INLET TEMPERATURE</b>	+1.5°C (35°F)	+1.5°C (35°F)
<b>MAXIMUM INLET TEMPERATURE</b>	50°C (122°F)	50°C (122°F)

REVISIONS			
REV.	DESCRIPTION	DATE	APPROVED
C-01	SPECIFICATION UPDATED	5-3-12	ME
C-04	TABLE UPDATES	03/02/2021	
C-05	TABLE UPDATE	08/02/2021	
C-06	TABLE INFO (PUSH-IN CONNECTIONS) UPDATED	09/12/2021	

NOTES:

GENERAL TOLERANCES UNLESS OTHERWISE STATED:  
X ± 0.5mm | X.X ± 0.25mm | X.XX ± 0.1mm  
ANGLES ± 0.5°

	DRAWN	CHECKED	APPROVED
NAME	PC	ME	ME
DATE	16/03/10	27/08/10	02/09/10

nano-porous solutions limited  
www.n-psl.com

© NANO-POROUS SOLUTIONS LTD 2014. THE ORIGINAL OF THIS DRAWING IS COPYRIGHT AND CONTAINS CONFIDENTIAL INFORMATION. IT IS THE PROPERTY OF NANO-POROUS SOLUTIONS LTD WITHOUT WHOSE PERMISSION IT MAY NOT BE COPIED, SHOWN OR HANDLED TO A THIRD PARTY OR OTHERWISE USED AND IT IS TO BE RETURNED PROMPTLY UPON REQUEST TO NANO-POROUS SOLUTIONS LTD.

MATERIAL:	ASSY	WEIGHT (KG):	
FINISH:			

TITLE: **D1 COMPRESSED AIR DRYER (NDL-010 - NDL-050)**

DWG NO. PD-0001	REVISION: <b>C-07</b>
SCALE - 1:3	SHEET 1 of 1
DO NOT SCALE DRAWING	SHEET SIZE A2