

DRAIN PORT TYPE:	MAX. ALLOWABLE WORKING PRESSURE:
AUTOMATIC	16 barg (232 psig)
ADAPTOR	16 barg (232 psig)

GENERAL PROPERTIES	
<b>FILTER MODEL OPTIONS (ELEMENT MODEL):</b>	
GF 0280 WS	GF 0325 WS
<b>PORT SIZE (A) VALID FOR G &amp; NPT CONNECTIONS:</b>	
1 1/4"	1 1/2"
<b>FLOW RATE:</b>	
132.2 l/s (280 SCFM)	151.4 l/s (321 SCFM)

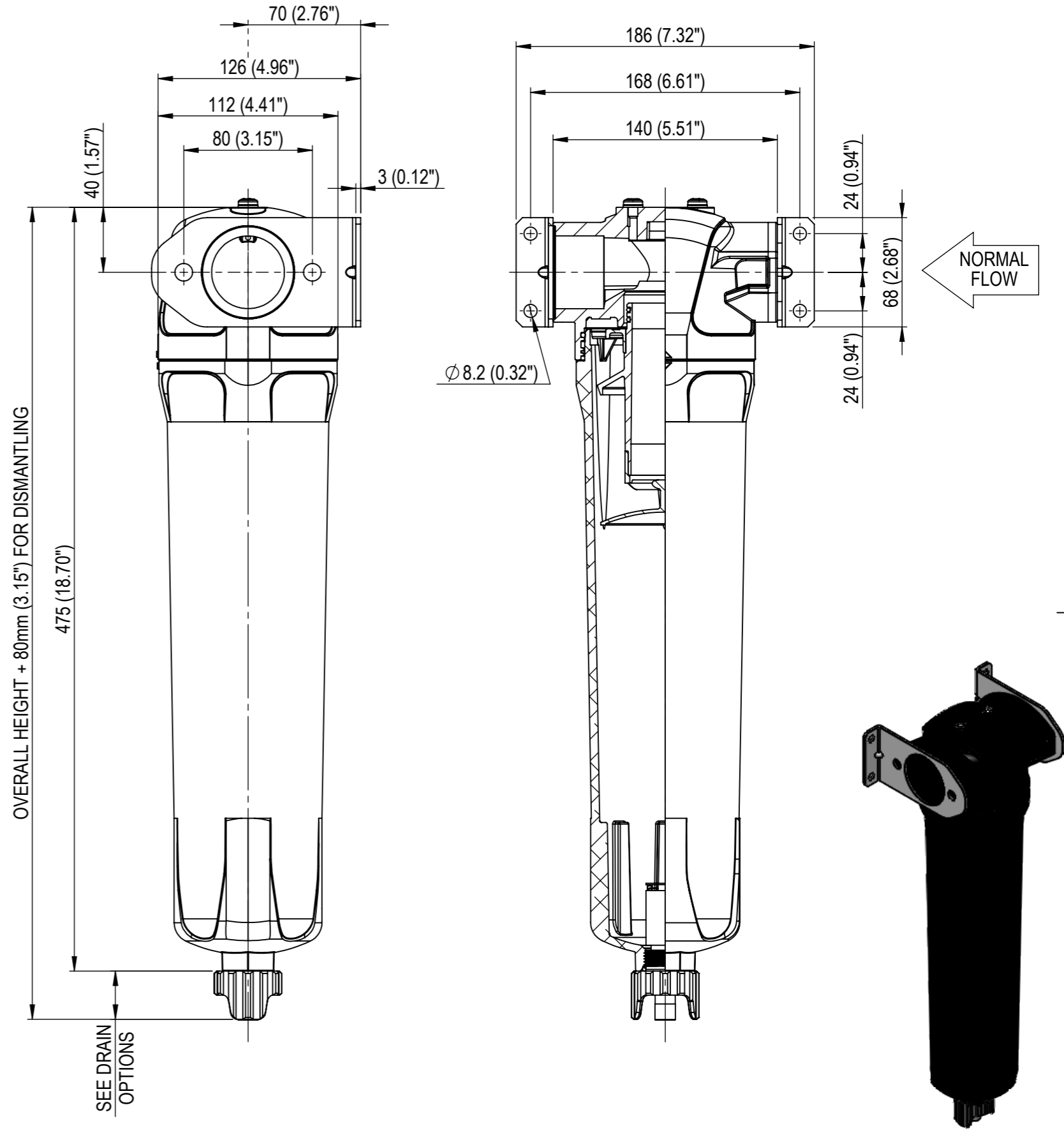

\* CLASS IN ACCORDANCE WITH ISO8573-1:2010  
\*\* FLOW DIRECTION VISUALLY INDICATED ON FILTER HOUSING

				PROJECT REFERENCE		DRG. TITLE <b>SIZE 9 &amp; 10 WATER SEPARATOR SPECIFICATION</b>	DRG. NUMBER A3- 42-1430	MATERIAL N/A	CHECK IA	REV A
				DESIGN REF						
		CREATED BY IA	DATE 19.8.19							
		REVISED BY JL	DATE 13.9.19							
REV	CHANGE ORDER	DATE	BY							