

All materials supplied are in compliance with the requirements of the List of Prohibited Substances

AS SHOWN: FILTERS: NF 0070M1 + NF 0070M01
MEMBRANE DRYER: DHM 0075 55F

2

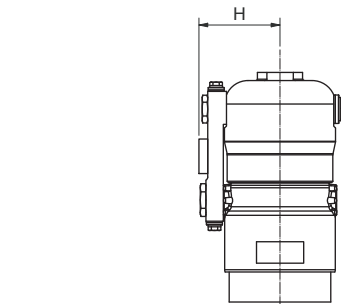
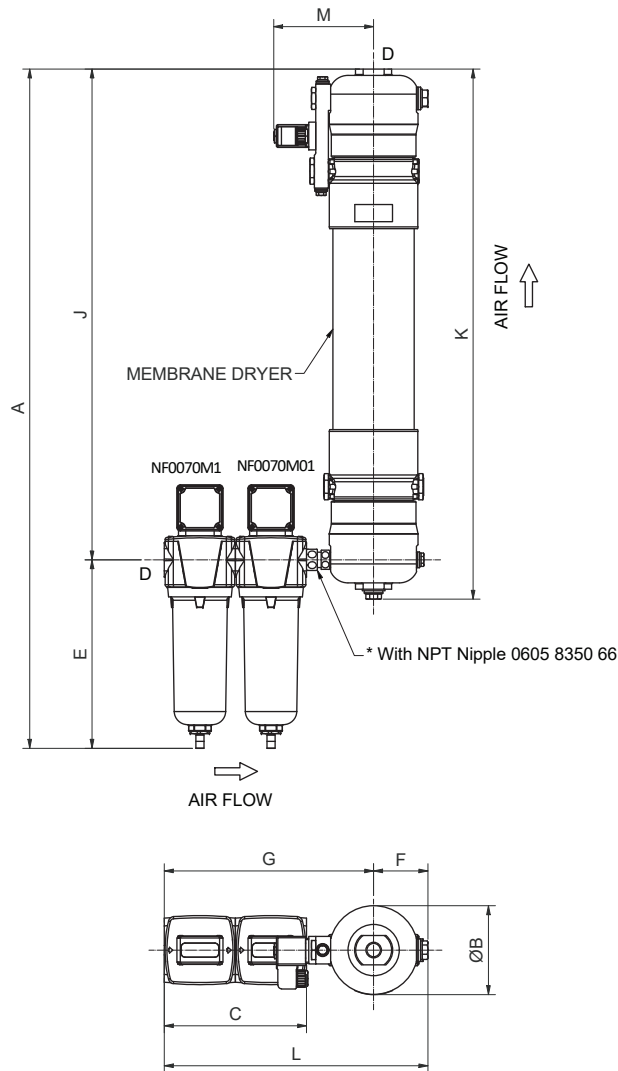

DETAIL: DRYER WITHOUT SOLENOID VALVE

2 * With NPT Nipple 0605 8350 66

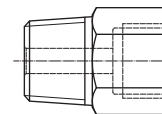

2

Membrane Dryer Type	Filter	A	ØB	C	D	E	F	G	H	J	K	L	M
DHM 0005 55F	NF 0050	744	55.4	140	G1/2	235	41	195	56	509	543	236	106
DHM 0010 55F	NF 0050	744	55.4	140	G1/2	235	41	195	56	509	543	236	106
DHM 0020 55F	NF 0050	934	78.5	140	G1/2	235	52	211	68	699	747	264	118
DHM 0030 55F	NF 0050	934	78.5	140	G1/2	235	52	211	68	699	747	264	118
DHM 0040 55F	NF 0050	909	99.6	140	G1/2	235	63.5	222	79	674	722	284	128
DHM 0050 55F	NF 0050	909	99.6	140	G1/2	235	63.5	222	79	674	722	284	128
DHM 0075 55F	NF 0070	963	125	200	G1/2	265	76	294	91	690	745	371	141
DHM 0003 100F	NF 0050	927	55.4	140	G1/2	235	41	195	56	692	724	236	106
DHM 0007 100F	NF 0050	1270	55.4	140	G1/2	235	41	195	56	1035	1069	236	106
DHM 0013 100F	NF 0050	1277	78.5	140	G1/2	235	52	211	68	1042	1090	264	118
DHM 0019 100F	NF 0050	1277	78.5	140	G1/2	235	52	211	68	1042	1090	264	118
DHM 0028 100F	NF 0050	1275	99.6	140	G1/2	235	63.5	222	79	1039	1087	284	128
DHM 0036 100F	NF 0050	1275	99.6	140	G1/2	235	63.5	222	79	1039	1087	284	128
DHM 0055 100F	NF 0070	1344	125	200	G1/2	265	76	294	91	1071	1126	371	141

Tolerances, if not indicated, according to:		General tolerances		
STANDARD CLASS		1350K - m		
Name	DIMENS. DRWG		DHM DRYER VERTICAL SET UP	
Material	Not Applicable		Internal	
Treatment	Not Applicable		INV	
Scale 1:5		Family	A2/Compare	
Drawn by INEBM		Blank nr.		Replaces
Version Drwg 01.00		Blank wt. 0 Kg		Designation
Des checked.		Prod checked.	Approved.	Date 10-07-2021
Parent 3D model		Ed. Version 3D		Sheet 1 / 1
Released				9827730603-01

CONFIDENTIAL: This document is our property and shall not be reproduced, stored in a retrieval system, or transmitted in any form or by any means, electronic, mechanical, photocopying, recording, or by any information storage and retrieval system, without our prior written permission.

2	Table modified. Nipple added.	06-04-2022	INEshma
Ed	Position	Modified from	Date
		Intr./Appd.	