

All materials supplied are in compliance with the requirements of the List of Prohibited Substances

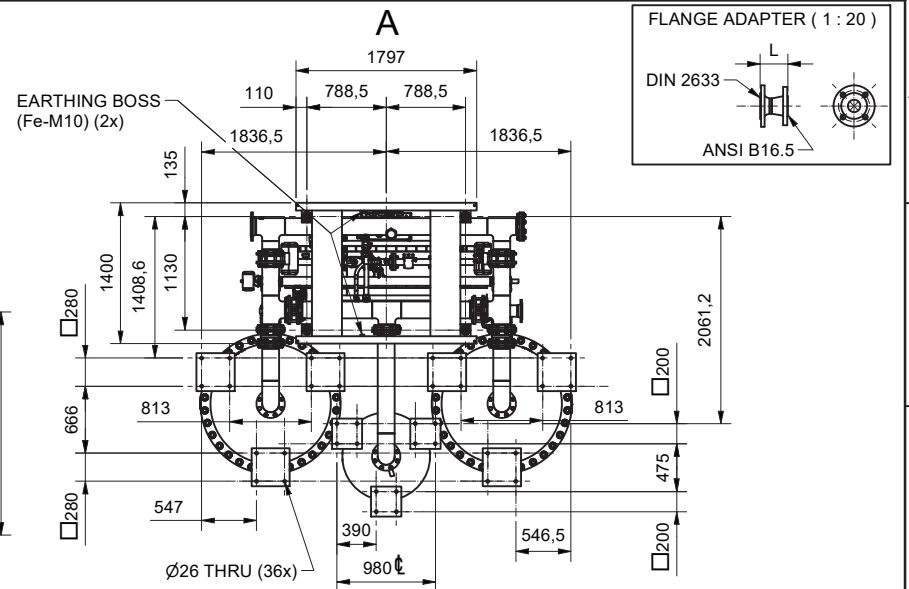
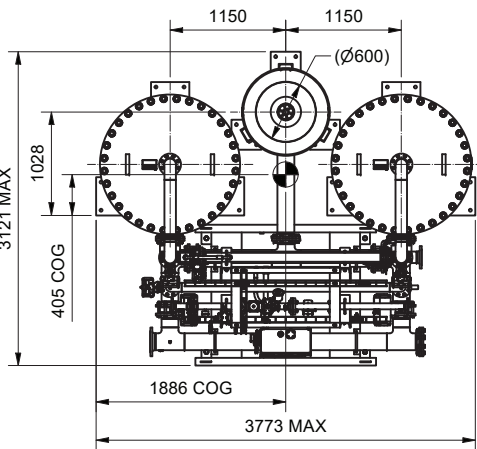
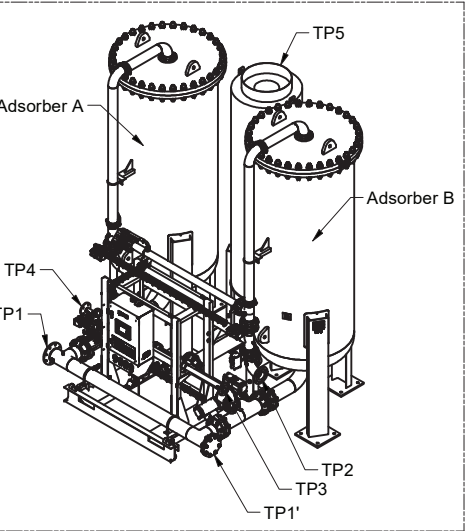
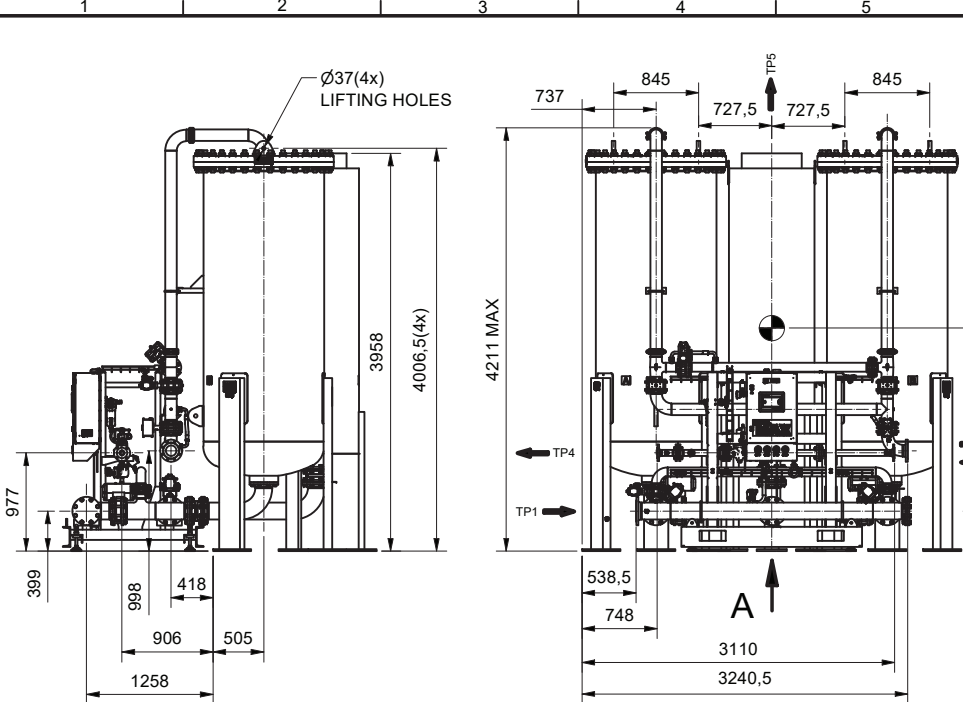

Note:
 ASME units will be delivered with the DIN to ANSI adapters (shipped as loose items), to be installed on TP1 to TP4

Weights:
 Total vessel weight (filled, each) : 4302 Kg
 Silencer : 685 Kg
 Frame including pipeset : 1232 kg

● Center of Gravity (±100mm)

| TIE- IN POINTS | | | | | | |
|----------------|--------------------|----------|--------|------------|--------|------------------------------------|
| SYMBOL | DESCRIPTION | DIN 2633 | | ANSI B16.5 | | DIN to ANSI Adapter Length (L)(mm) |
| | | SIZE | RATING | SIZE | RATING | |
| TP1 | AIR INLET | DN150 | PN16 | 6" | 150Lbs | 145 |
| TP1' | AIR INLET REVERSED | DN150 | PN16 | 6" | 150Lbs | 145 |
| TP2 | TO PRODUCT TANK | DN100 | PN16 | 4" | 150Lbs | 130 |
| TP3 | FROM PRODUCT TANK | DN50 | PN16 | 2" | 150Lbs | 110 |
| TP4 | GAS OUTLET | DN50 | PN16 | 2" | 150Lbs | 110 |
| TP5 | WASTE EXHAUST GAS | Ø600mm | | Ø600mm | | NA |

| | | | | | | |
|---|--|----------------|--|------------------|--|--------------------------------------|
| Tolerances, if not indicated, according to: | | | | | | |
| STANDARD CLASS | | | | | | |
| Name | | DIMENS. DRWG | | GEN2-MAX 39K PPM | | Confidentiality Class acc. to 1102 K |
| Material | | Not applicable | | | | Internal |
| Treatment | | Not Applicable | | | | INV |
| Scale | | 1 : 50 | | Family | | A3 Compare |
| Drawn by | | INEBM | | Blank nr. | | Replaces |
| Version Drwg | | Blank wt | | Kg Fini wt. | | Designation |
| Des checked. | | Prod checked. | | Approved. | | Date |
| Released | | | | | | 19/01/2022 |
| | | | | | | Sheet 1 / 1 |
| | | | | | | 1607011170-01 |

CONFIDENTIAL:
 This document is our property and shall not without our permission be altered, copied, used for manufacturing or communicated to any other person or company.

| | | | | | |
|----|---------------|------------|-------------|-----------------|-----------------|
| 1 | | 21/04/2022 | User Agent | 1607011170-M1 | |
| Ed | Position | Date | Intr./Appd. | Parent 3D model | Ed . Version 3D |
| | Modified from | | | | |

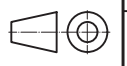

Drawing owner
 NLY