

All materials supplied are in compliance with the requirements of the List of Prohibited Substances

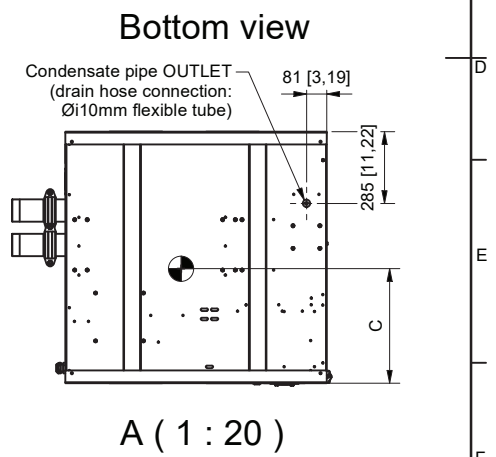
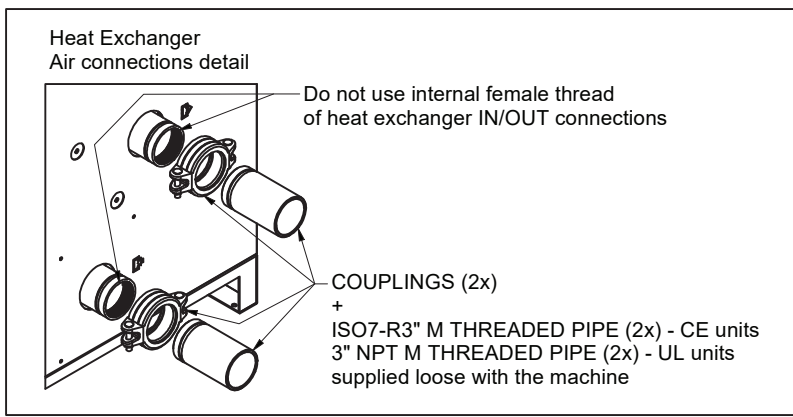
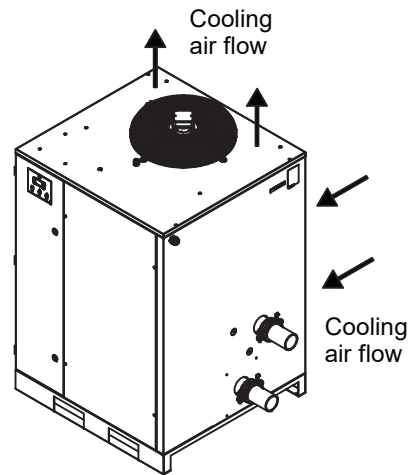
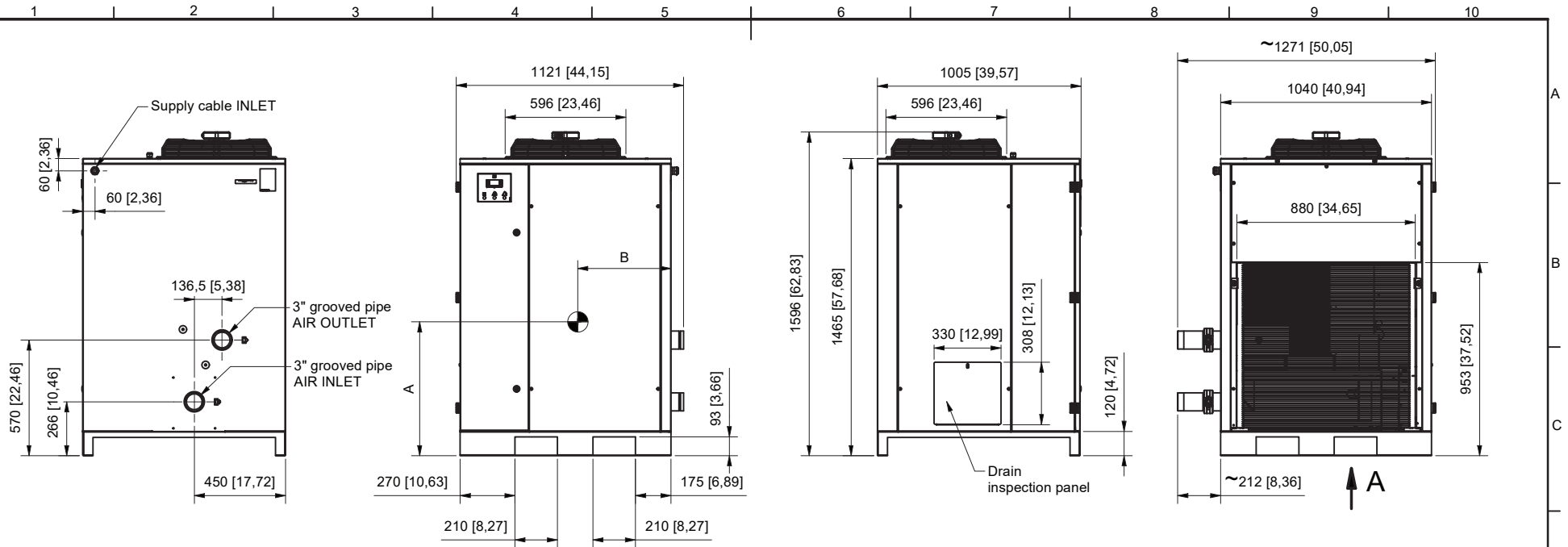

Weights and quotes (mm [inch]) - approx.						
Dryer	Variant	A	B	C	Weight	
DXR1050N	400V / 460V / 380V	668 [26,30]	448 [17,64]	457 [17,99]	325 kg / 717 lb	
DXR1050N	575V	652 [25,67]	462 [18,19]	448 [17,64]	335 kg / 739 lb	
DXR1250N	400V / 460V / 380V	674 [26,54]	456 [17,95]	460 [18,11]	338 kg / 745 lb	
DXR1250N	575V	658 [25,91]	468 [18,43]	452 [17,80]	348 kg / 767 lb	

Centre of gravity  
All dimensions: mm [inch]

00	First release. CID28382. DN22054160	10-26-2022	caisson	9828084787	
Ed	Modified from	Date	Intr./Appd.	Parent 3D model	Ed . Version 3D

Tolerances, if not indicated, according to:					
Name DIM. DRWG E16-17 - DXR1050N - DXR1250N					
Material Not Applicable				Confidentiality Class acc. to 1102 K Internal	
Treatment Not Applicable				INV	
Scale 1 : 20		Family		Compare	
Drawn by caisson		Blank nr.		Replaces	
Drawing format Blank wt				Fini wt.	
STATUS A3		Kg		See Drawing	
Des checked.		Prod checked.		Approved.	
Date 05/07/2022		Designation		Sheet 1 / 1	
Approved Internal				9828084787	

CONFIDENTIAL: This document is our property and shall not be used without our permission. It is not to be copied, used for manufacturing or communicated to any other person or company.