

All materials supplied are in compliance with the requirements of the List of Prohibited Substances

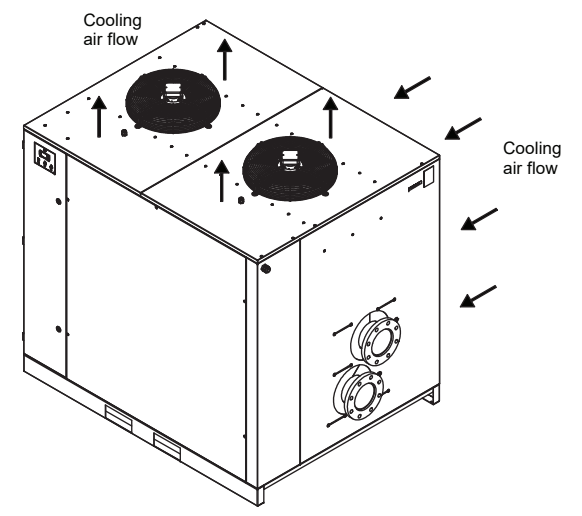
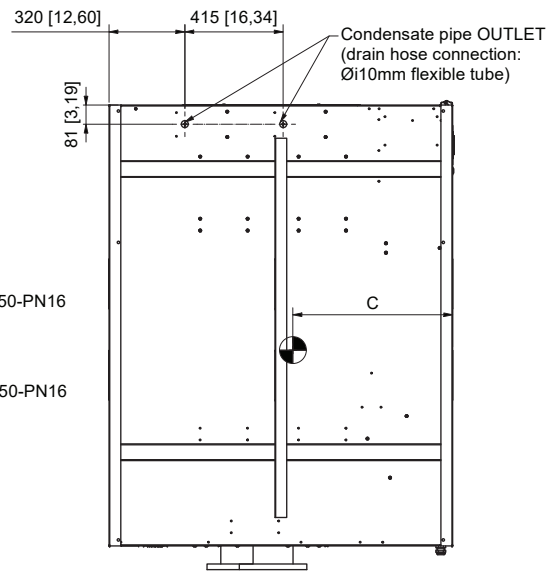
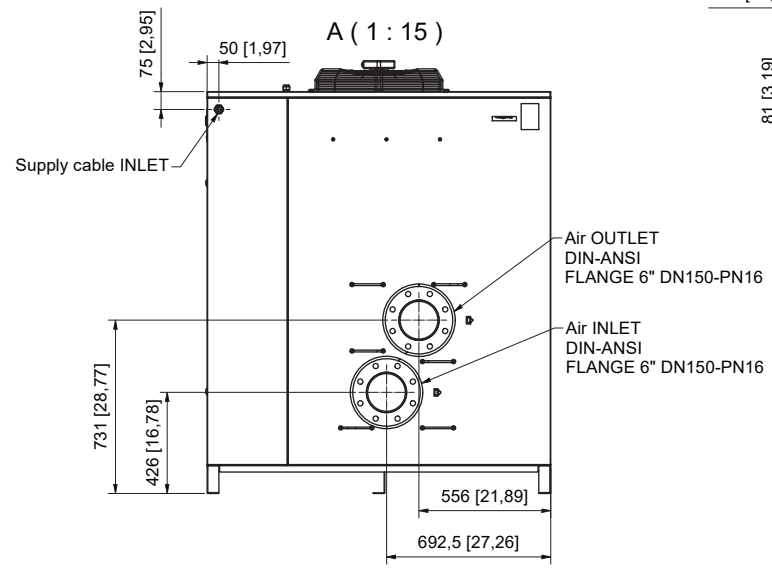
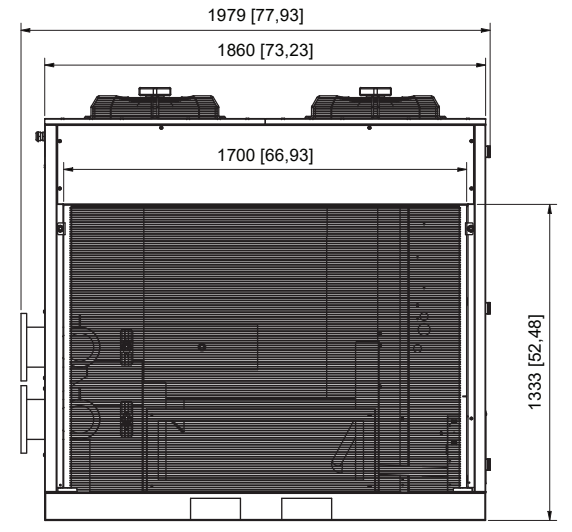
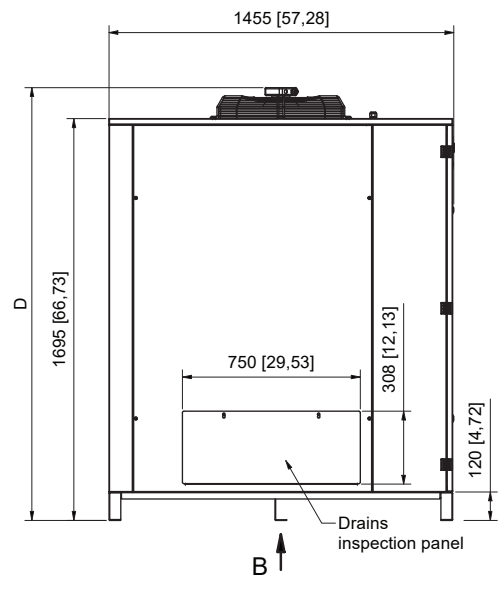
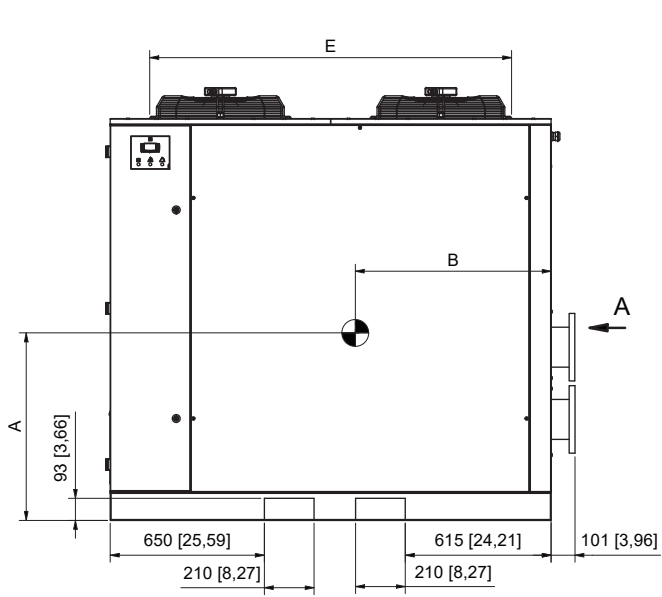

Dryer	Variant	A	B	C	D	E	Weight
DXR3000N	400V / 460V / 380V	793 [31,22]	828 [32,60]	676 [26,61]	1826 [71,89]	1527 [60,10]	810 kg / 1786 lb
DXR3000N	575V	784 [30,87]	839 [33,03]	670 [26,38]	1826 [71,89]	1527 [60,10]	825 kg / 1819 lb
DXR3500N	400V / 460V / 380V	791 [31,14]	826 [32,52]	674 [26,54]	1826 [71,89]	1527 [60,10]	815 kg / 1797 lb
DXR3500N	575V	783 [30,83]	837 [32,95]	668 [26,30]	1826 [71,89]	1527 [60,10]	830 kg / 1830 lb
DXR4200N	400V / 460V / 380V	834 [32,83]	887 [34,92]	682 [26,85]	1833 [72,17]	1659 [65,30]	900 kg / 1984 lb
DXR4200N	575V	826 [32,52]	897 [35,32]	676 [26,61]	1833 [72,17]	1659 [65,30]	917 kg / 2022 lb

B (1:15)
Bottom view

Centre of gravity
All dimensions: mm [inch]

Tolerances, if not indicated, according to:					
Name	DIM. DRWG E20-22 - DXR3000N- DXR4200N			Confidentiality Class acc. to TRG K	
Material	Not Applicable			Internal	
Treatment	Not Applicable			INV	
Scale	1 : 15	Family		Compare	
Drawn by	caisbon	Blank nr.		Replaces	
Drawing format	A2	Blank wt.		Designation	
STATUS	Des checked.	Prod checked.	Approved.	Date	21/07/2022
Parent 3D model	9828084790	Ed . Version 3D		Sheet	1 / 1
Approved Internal				9828084790	

CONFIDENTIAL: This document is our property and shall not be without our permission be altered, copied, reproduced or disseminated in any form or by any means, electronic or mechanical, including photocopying, recording, or by any information storage and retrieval system.

Ed	Position	Modified from	Date	Intr./Appd.
00		First release. CID28382. DN2054160	10-26-2022	caisbon