

All materials, supplies, etc. in compliance with the requirements of the List of Prohibited Substances

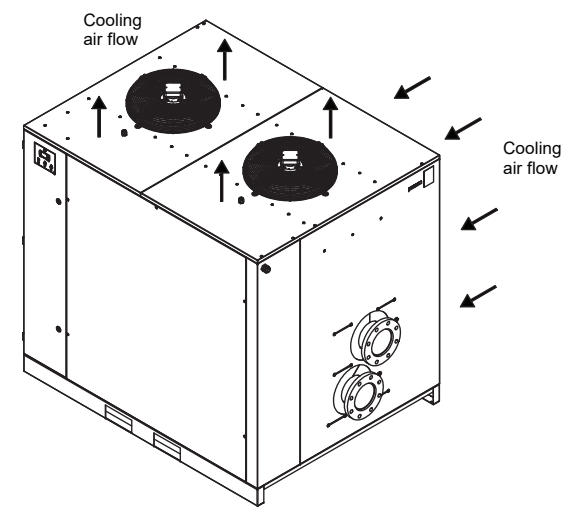
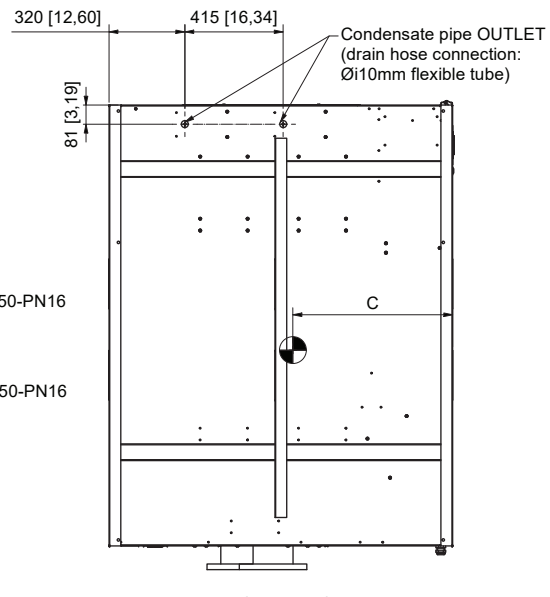
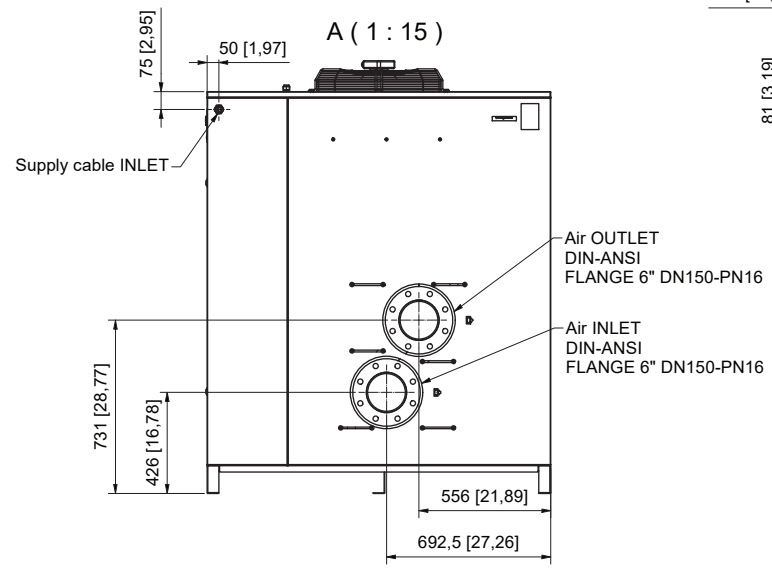
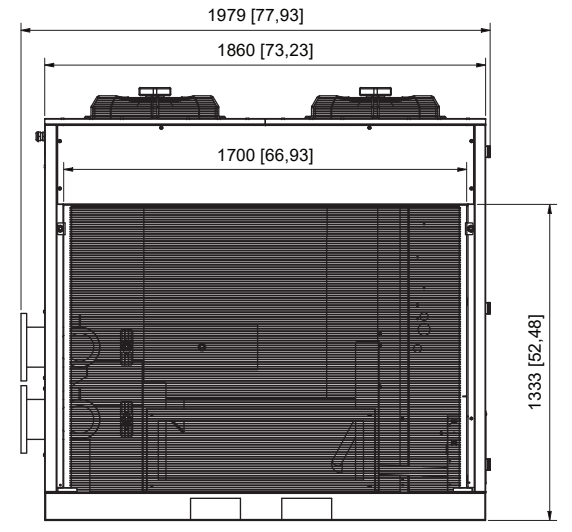
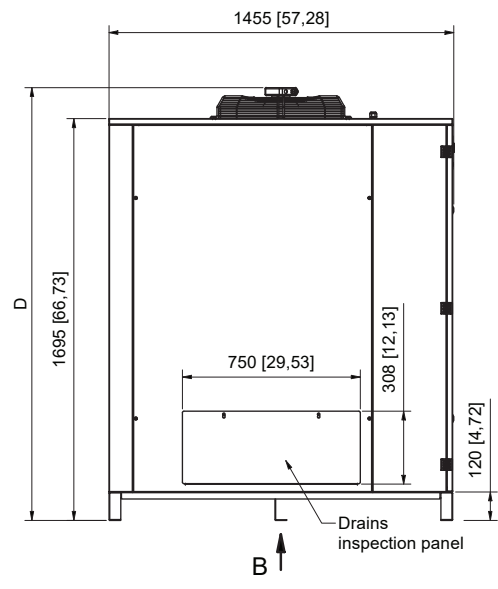
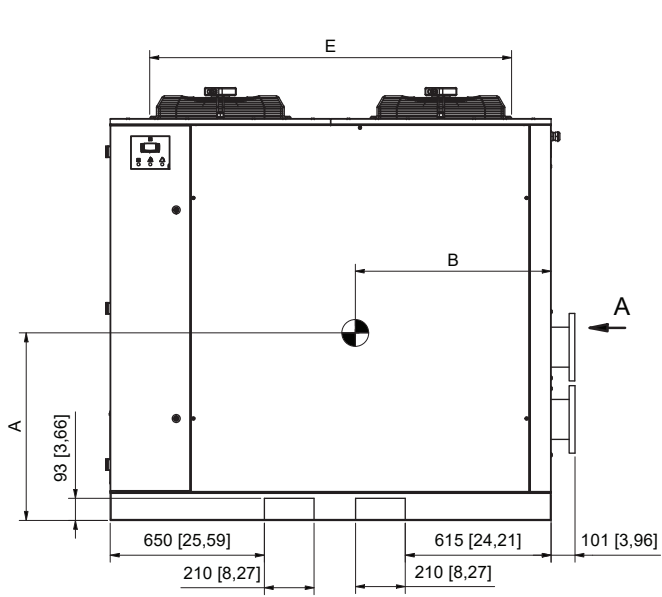

**B (1 : 15)**  
Bottom view

Weights and quotes (mm [inch]) - approx.							
Dryer	Variant	A	B	C	D	E	Weight
E20	400V / 460V / 380V	793 [31,22]	828 [32,60]	676 [26,61]	1826 [71,89]	1527 [60,10]	810 kg / 1786 lb
E20	575V	784 [30,87]	839 [33,03]	670 [26,38]	1826 [71,89]	1527 [60,10]	825 kg / 1819 lb
E21	400V / 460V / 380V	791 [31,14]	826 [32,52]	674 [26,54]	1826 [71,89]	1527 [60,10]	815 kg / 1797 lb
E21	575V	783 [30,83]	837 [32,95]	668 [26,30]	1826 [71,89]	1527 [60,10]	830 kg / 1830 lb
E22	400V / 460V / 380V	834 [32,83]	887 [34,92]	682 [26,85]	1833 [72,17]	1659 [65,30]	900 kg / 1984 lb
E22	575V	826 [32,52]	897 [35,32]	676 [26,61]	1833 [72,17]	1659 [65,30]	917 kg / 2022 lb

Centre of gravity  
All dimensions: mm [inch]

Tolerances, if not indicated, according to:							
Name DIM. DRWG E20-22						Confidentiality Class acc. to ITC 10	
Material Not Applicable						Internal	
Treatment Not Applicable						INV	
Scale 1 : 15		Family		Compare		Drawing Owner	
Drawn by caisbon		Blank nr.		Replaces		Transferred from	
Drawing format A2		Blank wt. Kg		Designation		Sheet 1 / 1	
STATUS		Des checked.		Prod checked.		Approved.	
Parent 3D model		Ed . Version 3D		Date 21/07/2022		9828084790	

CONFIDENTIAL: This document is our property and shall not be disclosed or used without our permission. All rights reserved. No part of this document may be reproduced or transmitted in any form or by any means electronic or mechanical, including photocopying and recording, or by any information storage or retrieval system, without the prior written permission of the company.

00	First release. CID28382. DN2054160	10-26-2022	caisbon
Ed	Position	Modified from	Date
		Intr./Appd.	

9828084790	
Parent 3D model	Ed . Version 3D

Approved Internal