

REVISION				
REV.	ECN	DESCRIPTION	DATE	DESIGNER

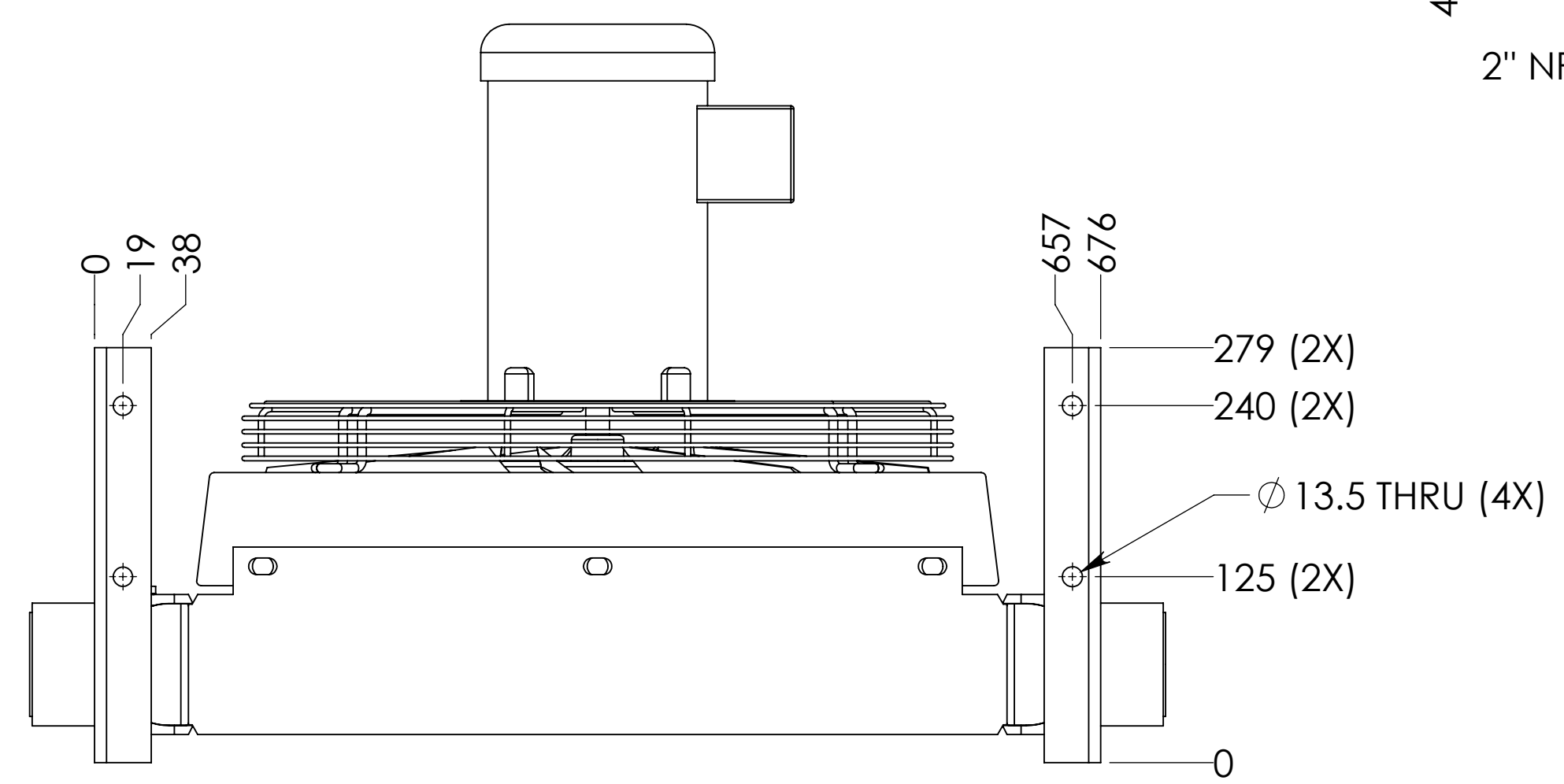
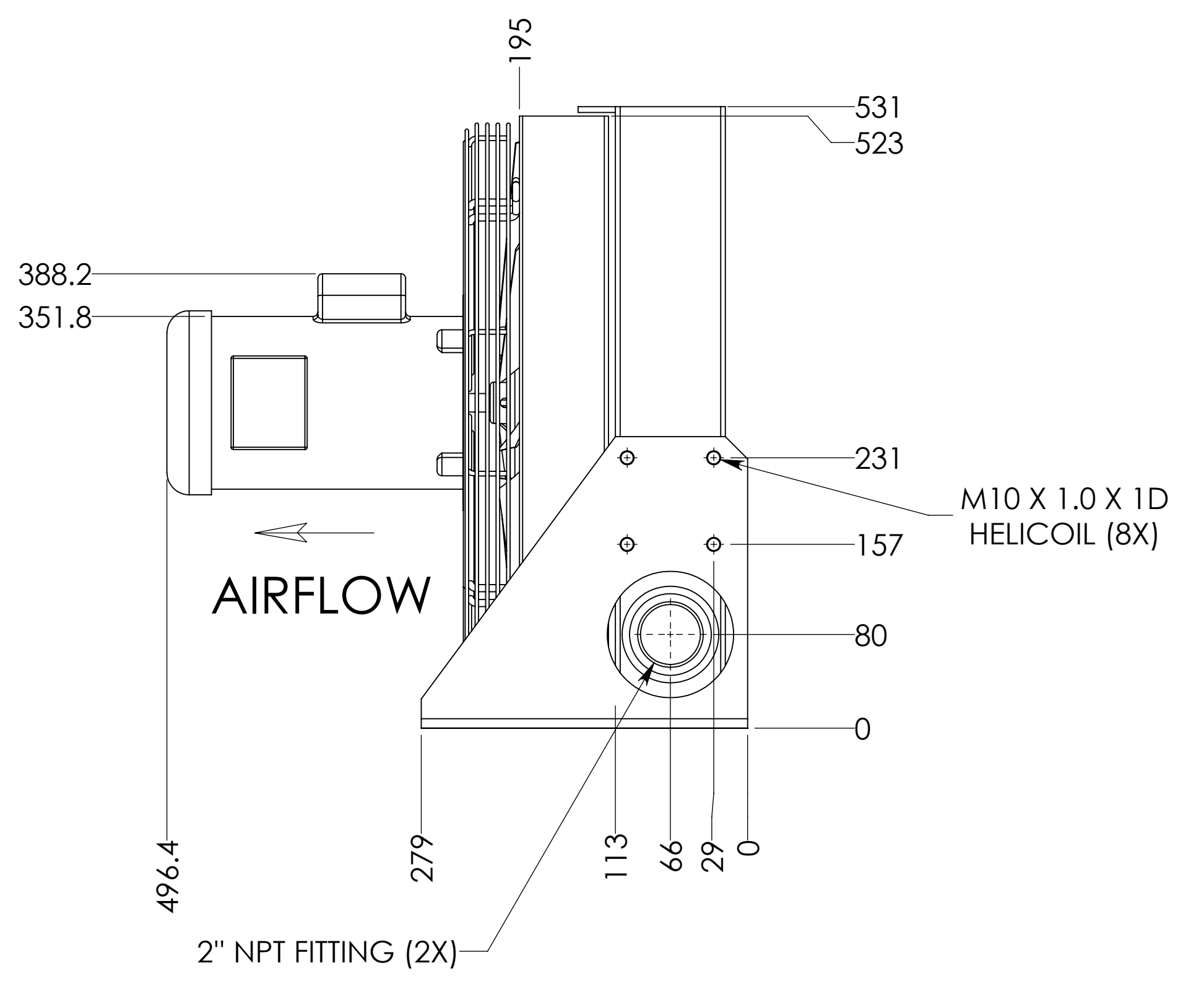
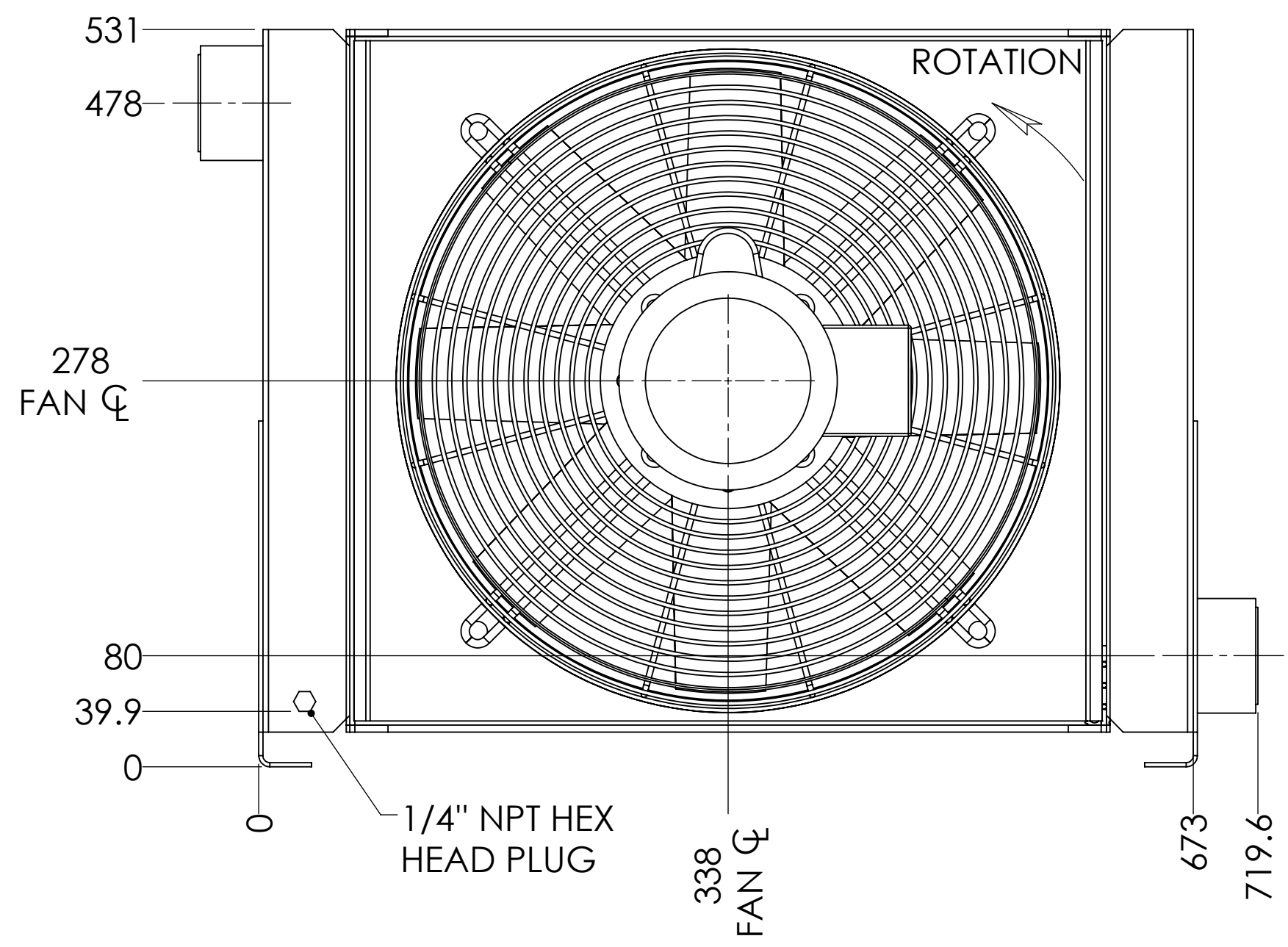

Work Pressure (psi) (Max)	250
Test Pressure (psi) (Max)	190
Max Temperature (°F)	250
Paint	BLACK
Customer Part No:	-

UNLESS OTHERWISE SPECIFIED
ALL DIMENSIONS ARE mm
AND ARE REFERENCE

PROJECTION:



THE INFORMATION HEREON IS THE PROPERTY OF AKGTS. ANY COPYING OR TRANSMITTAL WITHOUT PERMISSION FROM AKG OF AMERICA IS PROHIBITED

DRWN BY: SLATE
DATE: 1/10/17
ENGR: CHESTNUT

TITLE	CC450-1	
DWG. NO.	CC450-1	REV. -
PAGE:	1 of 2	

REVISION				
REV.	ECN	DESCRIPTION	DATE	DESIGNER

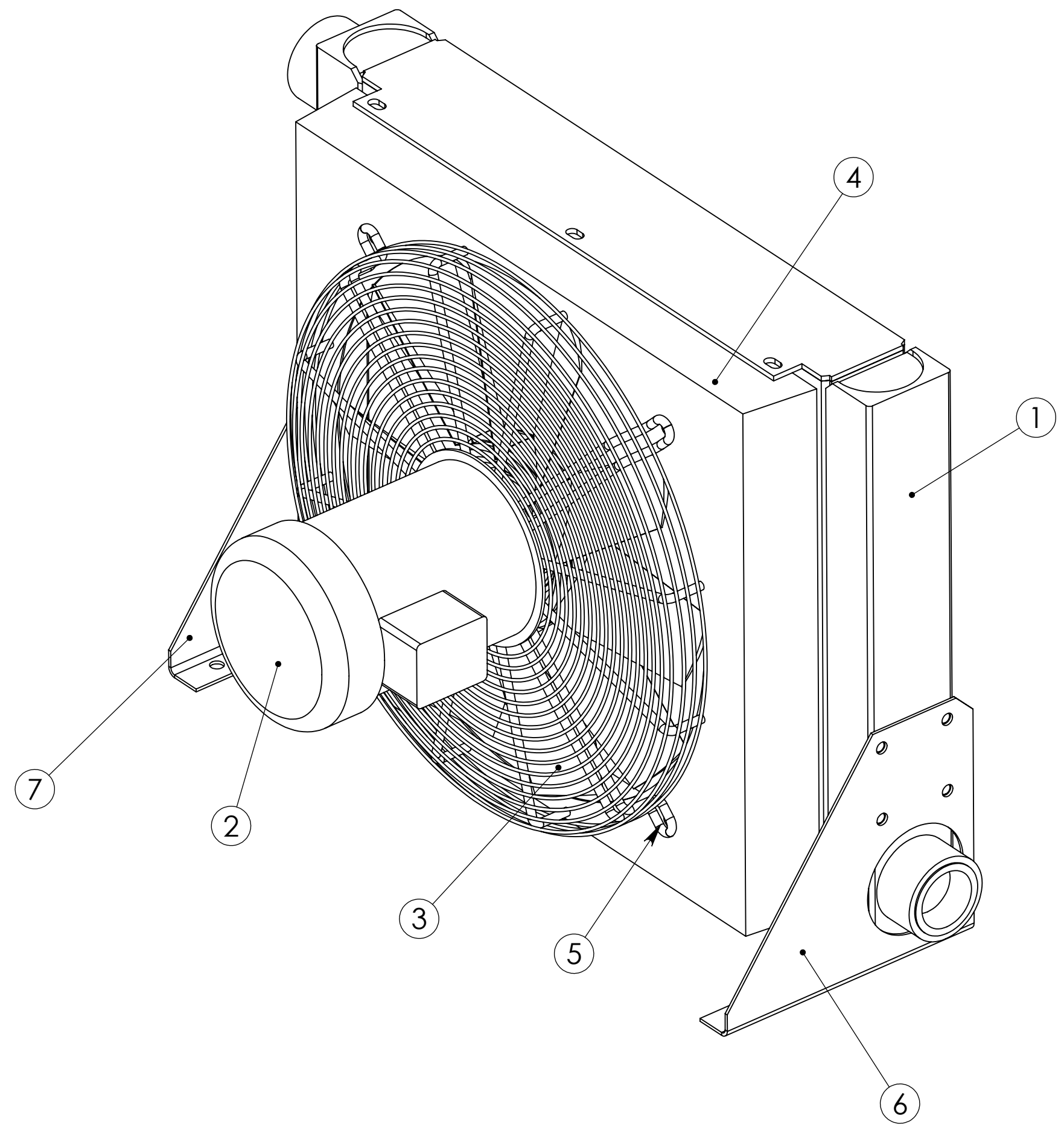

ITEM NO.	QTY.	PART NUMBER	DESCRIPTION
7	1	3703.018.0002	MTG BRKT (L)
6	1	3703.018.0001	MTG BRKT (R)
5	1	3542.033.4030	FAN GUARD
4	1	1872.383.4010	SHROUD
3	1	8400.128.0018	FAN
2	1	8407.712.3102	MOTOR
1	1	CC450-C	CORE

Work Pressure (psi) (Max)	250	UNLESS OTHERWISE SPECIFIED ALL DIMENSIONS ARE mm AND ARE REFERENCE
Test Pressure (psi) (Max)	190	
Max Temperature (°F)	250	PROJECTION:
Paint	BLACK	
Customer Part No:	-	

AKG Thermal Systems, Inc.
 Mebane, NC 27302

THE INFORMATION HEREON IS THE PROPERTY
 OF AKGTS. ANY COPYING OR
 TRANSMITTAL WITHOUT PERMISSION FROM
 AKG OF AMERICA IS PROHIBITED

DRWN BY: **SLATE**
 DATE: **1/10/17**
 ENGR: **CHESTNUT**

TITLE	CC450-1	
DWG. NO.	CC450-1	REV. -
PAGE:	2 of 2	