

ITEM NO	QTY	DESCRIPTION
1	2	DESICCANT VESSEL
2	2	INLET BUTTERFLY VALVE
3	2	OUTLET CHECK VALVE
4	2	PURGE EXHAUST VALVE
5	2	EXHAUST MUFFLER
6	3	PRESSURE GAUGE
7	2	PRESSURE RELIEF VALVE
8	1	ELECTRICAL ENCLOSURE
9	1	PRE-FILTER
10	1	AFTER FILTER

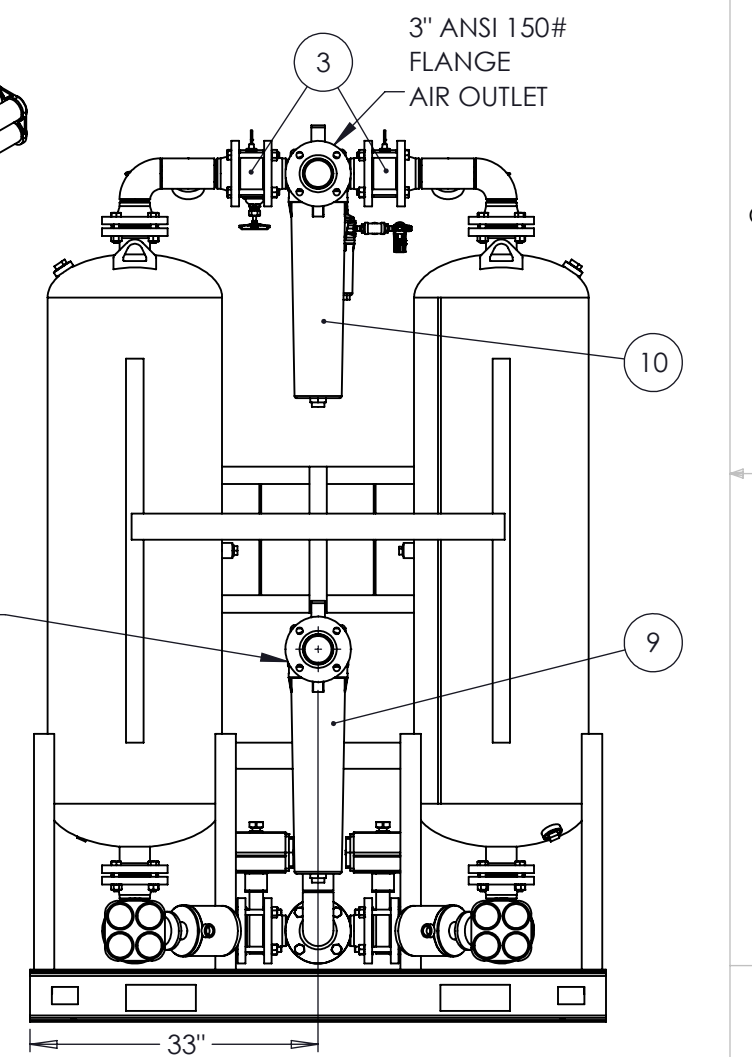

UNLESS OTHERWISE SPECIFIED:

DIMENSIONS ARE IN INCHES

TOLERANCES:

FRACTIONAL ± 0.125

ANGULAR: ± 0.5°

TWO PLACE DECIMAL ± .03

THREE PLACE DECIMAL ± .003

THIRD ANGLE PROJECTION

MATERIAL

FINISH

DO NOT SCALE DRAWING

	NAME	DATE
DRAWN	BH	07/15/24
CHECKED		
ENG APPR.		
MFG APPR.		
Q.A.		
COMMENTS:		

**nano** NANO-PURIFICATION SOLUTIONS  
323 CRISP CIRCLE  
MARYVILLE, TENNESSEE 37801-USA

TITLE: DRYER, DESICCANT, HL1000 HEATLESS, PKG B, 1 PRE & AFTER FILTER; 1000 SCFM, 200 PSI, 100F, TL-20

SIZE **B** DWG. NO. 8102416008 REV **0**

SCALE: 1:50 WEIGHT: SHEET 1 OF 1

**PROPRIETARY AND CONFIDENTIAL**

THE INFORMATION CONTAINED IN THIS DRAWING IS SOLE PROPERTY OF NANO PURIFICATION SOLUTIONS. ANY REPRODUCTION IN PART OR WHOLE WITHOUT THE WRITTEN PERMISSION OF NANO PURIFICATION SOLUTIONS IS PROHIBITED.