

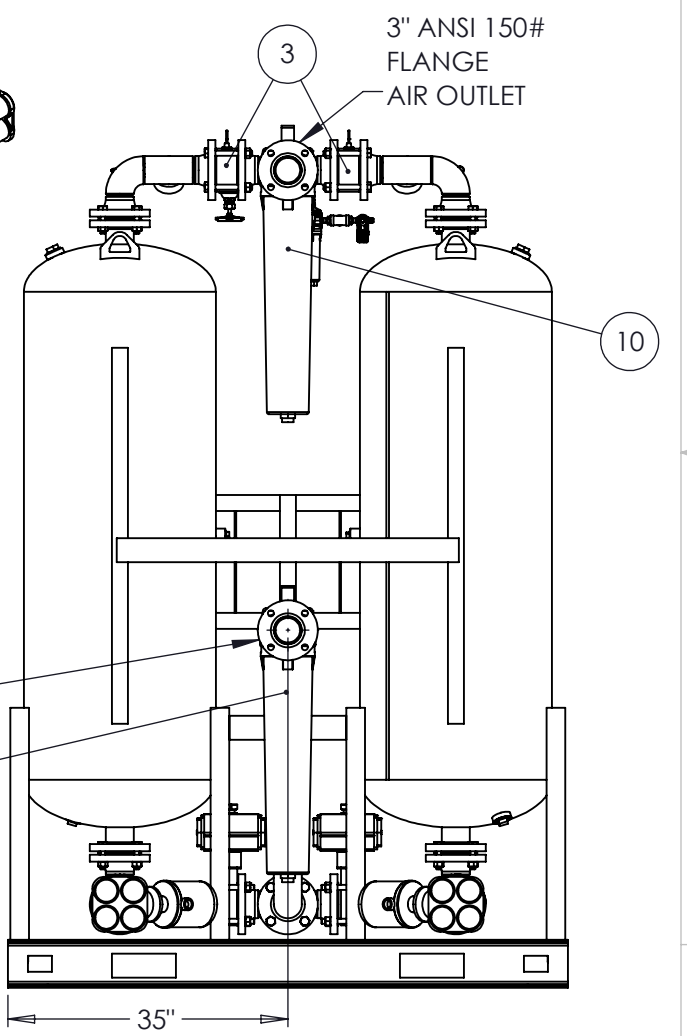

ITEM NO	QTY	DESCRIPTION
1	2	DESICCANT VESSEL
2	2	INLET BUTTERFLY VALVE
3	2	OUTLET CHECK VALVE
4	2	PURGE EXHAUST VALVE
5	2	EXHAUST MUFFLER
6	3	PRESSURE GAUGE
7	2	PRESSURE RELIEF VALVE
8	1	ELECTRICAL ENCLOSURE
9	1	PRE-FILTER
10	1	AFTER FILTER



UNLESS OTHERWISE SPECIFIED:		NAME	DATE	 NANO-PURIFICATION SOLUTIONS 323 CRISP CIRCLE MARYVILLE, TENNESSEE 37801-USA
DIMENSIONS ARE IN INCHES TOLERANCES: FRACTIONAL ± 0.125 ANGULAR: ± 0.5° TWO PLACE DECIMAL ± .03 THREE PLACE DECIMAL ± .003		DRAWN	BH	
 THIRD ANGLE PROJECTION		CHECKED		
MATERIAL		ENG APPR.		
FINISH		MFG APPR.		
DO NOT SCALE DRAWING		Q.A.		
		COMMENTS:		
PROPRIETARY AND CONFIDENTIAL THE INFORMATION CONTAINED IN THIS DRAWING IS SOLE PROPERTY OF NANO PURIFICATION SOLUTIONS. ANY REPRODUCTION IN PART OR WHOLE WITHOUT THE WRITTEN PERMISSION OF NANO PURIFICATION SOLUTIONS IS PROHIBITED.		TITLE: DRYER, DESICCANT, HL1250 ASSY, HEATLESS, PKG B, 1 PRE & AFTER FILTER; 1250 SCFM, 200 PSI, 100F, TL-24		
		SIZE	DWG. NO.	REV
		B	8102417008	0
		SCALE: 1:50	WEIGHT:	SHEET 1 OF 1