

MODEL	DIMENSION "A" / mm [INCHES]	DIMENSION "B" / mm [INCHES]	DIMENSION "C" / mm [INCHES]	DIMENSION TO AIR INLET / mm [INCHES]	DIMENSION N2 OUTLET mm [INCHES]	DIMENSION SAMPLE POINT / mm [INCHES]	DIMENSION FROM BUFFER / mm [INCHES]	DIMENSION TO POWER INLET / mm [INCHES]	DIMENSION TO BUFFER / mm [INCHES]	APPROX WEIGHT / KG (Lbs)
NNG-2110	650 [26]	382 [15]	210 [47]	271 [10.7]	407 [16]	271 [10.7]	497 [19.5]	598 [23.6]	1034 [41]	179 [394]
NNG-2130	650 [26]	382 [15]	1810 [71]	341 [13.5]	497 [19.6]	607 [23.9]	922 [36.3]	1125 [44.3]	1634 [64.3]	261 [575]
NNG-3110	820 [32]	550 [22]	1210 [47]	271 [10.7]	407 [16]	271 [10.7]	497 [19.5]	598 [23.6]	1034 [41]	249 [548]
NNG-3130	32 [820]	550 [22]	1810 [71]	341 [13.5]	497 [19.6]	607 [23.9]	922 [36.3]	1125 [44.3]	1634 [64.3]	331 [729]
NNG-4130	39 [990]	718 [28]	1810 [71]	341 [13.5]	497 [19.6]	607 [23.9]	922 [36.3]	1125 [44.3]	1634 [64.3]	439 [967]
NNG-6130	1320 [52]	1054 [41]	1810 [71]	341 [13.5]	497 [19.6]	607 [23.9]	922 [36.3]	1125 [44.3]	1634 [64.3]	623 [1373]
NNG-8130	1660 [65]	1390 [55]	1810 [71]	341 [13.5]	497 [19.6]	607 [23.9]	922 [36.3]	1125 [44.3]	1634 [64.3]	789 [1739]
NNG-10130	2000 [79]	1726 [68]	1810 [71]	341 [13.5]	497 [19.6]	607 [23.9]	922 [36.3]	1125 [44.3]	1634 [64.3]	883 [1946]
NNG-12130	2330 [92]	2026 [80]	1810 [71]	341 [13.5]	497 [19.6]	607 [23.9]	922 [36.3]	1125 [44.3]	1634 [64.3]	1110 [2447]

REVISIONS			
REV.	DESCRIPTION	DATE	APPROVED
C-03	TABLE & NOTE UPDATES	11/06/2014	ME
C-04	DATA UPDATED	10/12/2014	

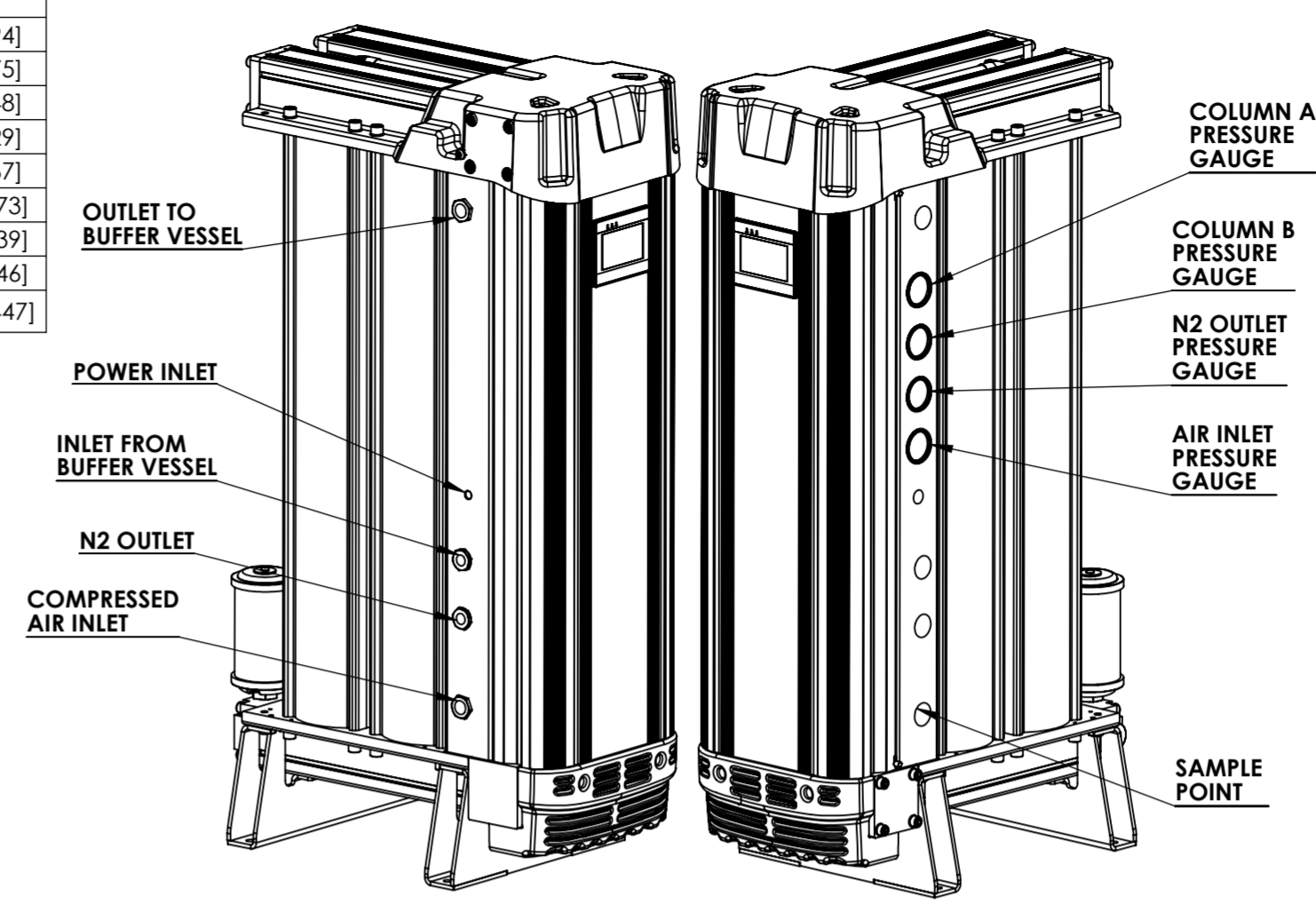

FOR NNG-2110 & 3110 NOTE THE SAMPLE POINT POSITION IS ON THE OPPOSITE SIDE TO THE COMPRESSED AIR INLET

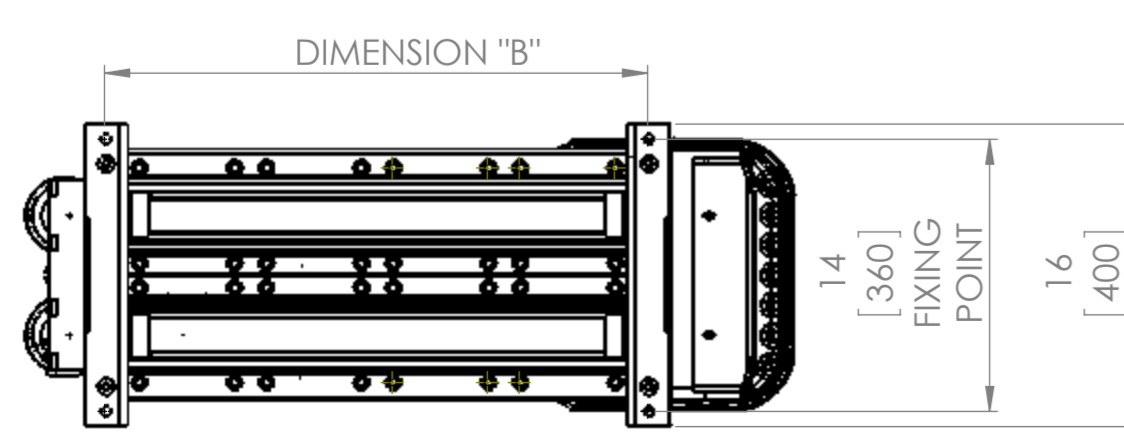
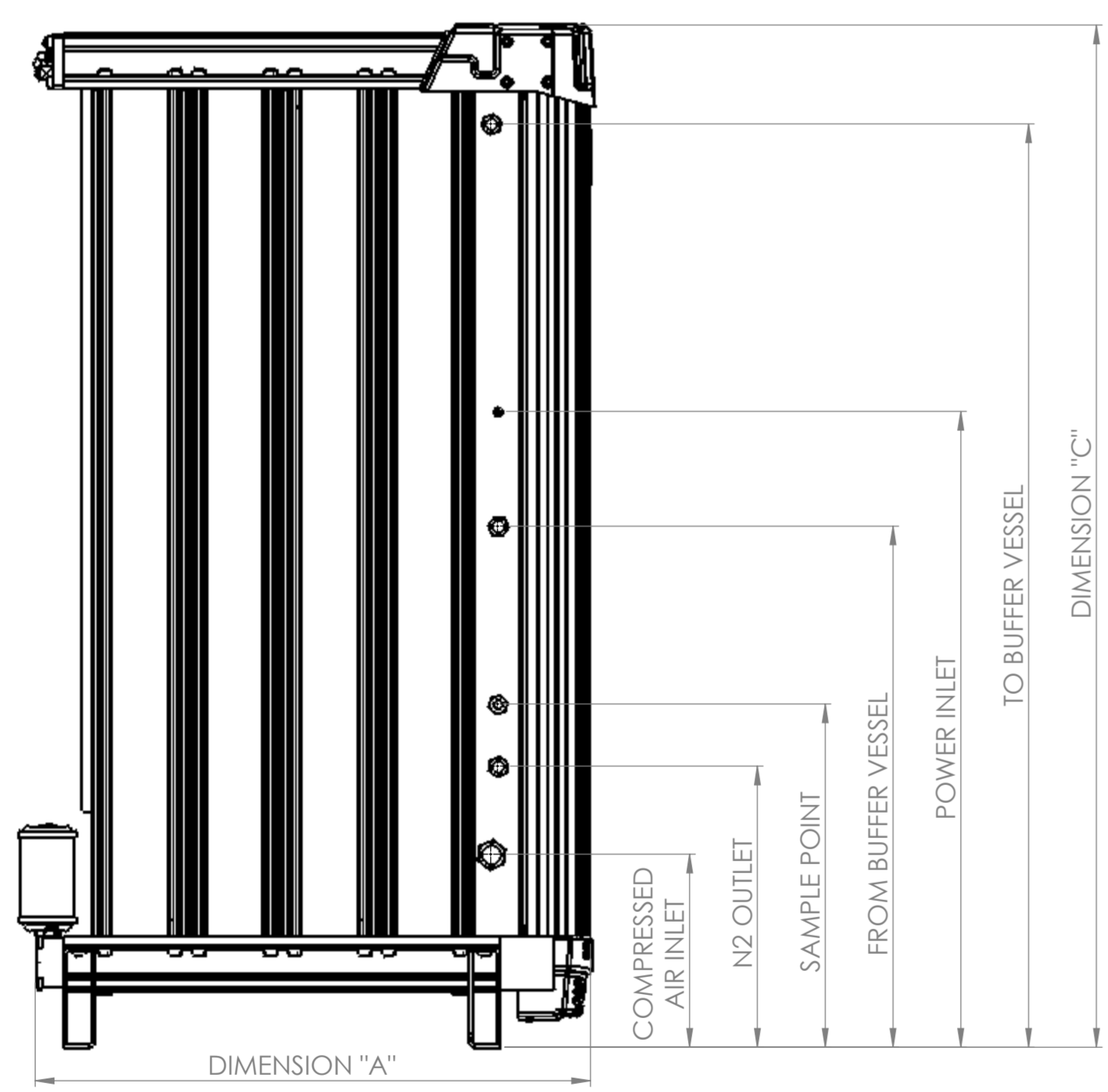
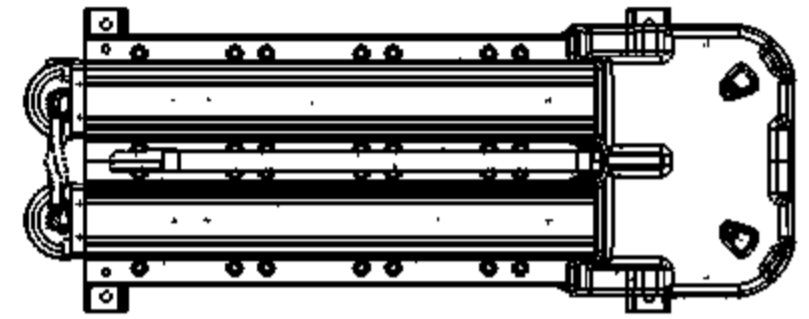
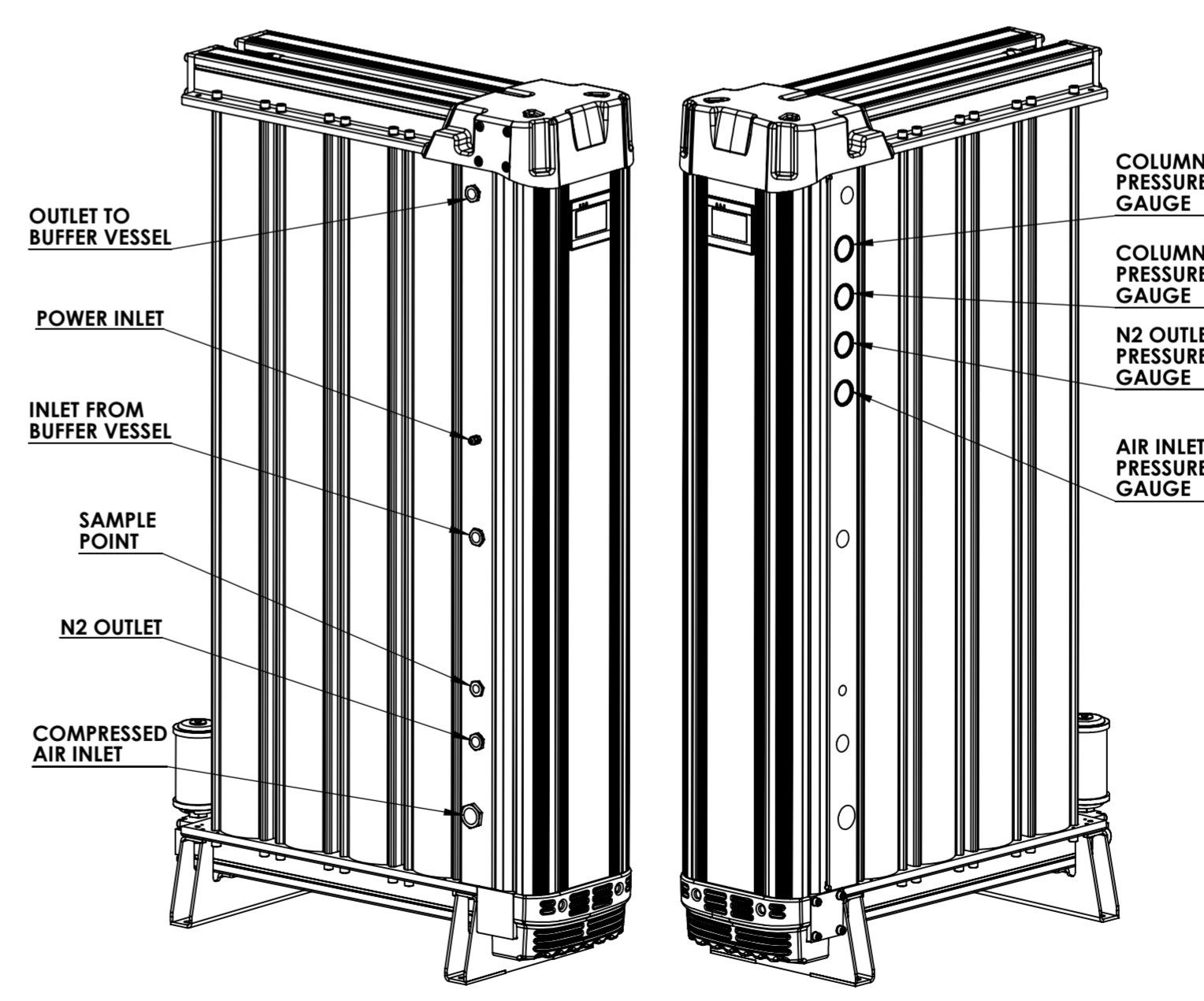

PICTORIAL VIEWS

SPECIFICATION

INLET AIR QUALITY -
ISO 8573:2010 CLASS 2.-.2
(2.2.1 WITH HIGH OIL VAPOUR CONTENT)

MINIMUM WORKING PRESSURE -
6 bar g (87 psi g)

MAXIMUM WORKING PRESSURE -
10 bar g (145 psi g)

SUPPLY VOLTAGE -
100-240V AC / 50-60 Hz or 24V DC

MINIMUM INLET TEMPERATURE -
1.5°C (35°F)

MAXIMUM INLET TEMPERATURE -
35°C (95°F)

CONNECTIONS

ALL CONNECTIONS ARE ROUTED TO THE LEFT HAND SIDE OF THE GENERATOR AS SHOWN

- COMPRESSED AIR INLET:**
1" BSPP (1" NPT)
- N2 OUTLET TO BUFFER**
1/2" BSPP VESSEL (1/2" NPT)
- N2 INLET FROM BUFFER**
1/2" BSPP VESSEL (1/2" NPT)
- N2 OUTLET**
1/2" BSPP (1/2" NPT)

GENERAL TOLERANCES UNLESS OTHERWISE STATED:
X ± 0.5mm | X.X ± 0.25mm | X.XX ± 0.1mm
ANGLES ± 0.5°

	DRAWN	CHECKED	APPROVED
NAME	RM	IC	PH
DATE	09/10/12	19/10/12	01/11/12

nano-porous solutions limited
www.n-psl.com

MATERIAL: ASSY WEIGHT: (KG):
FINISH: -
TITLE: SERIES 3 NITROGEN GENERATOR

DWG NO. PD-0012	REVISION: C-04
SCALE - 1:10	SHEET 1 of 1
DO NOT SCALE DRAWING	SHEET SIZE A2