

All materials supplied are in compliance with the requirements of the List of Prohibited Substances

VDR 2600-5050
AIRCOOLED

FRONT VIEW

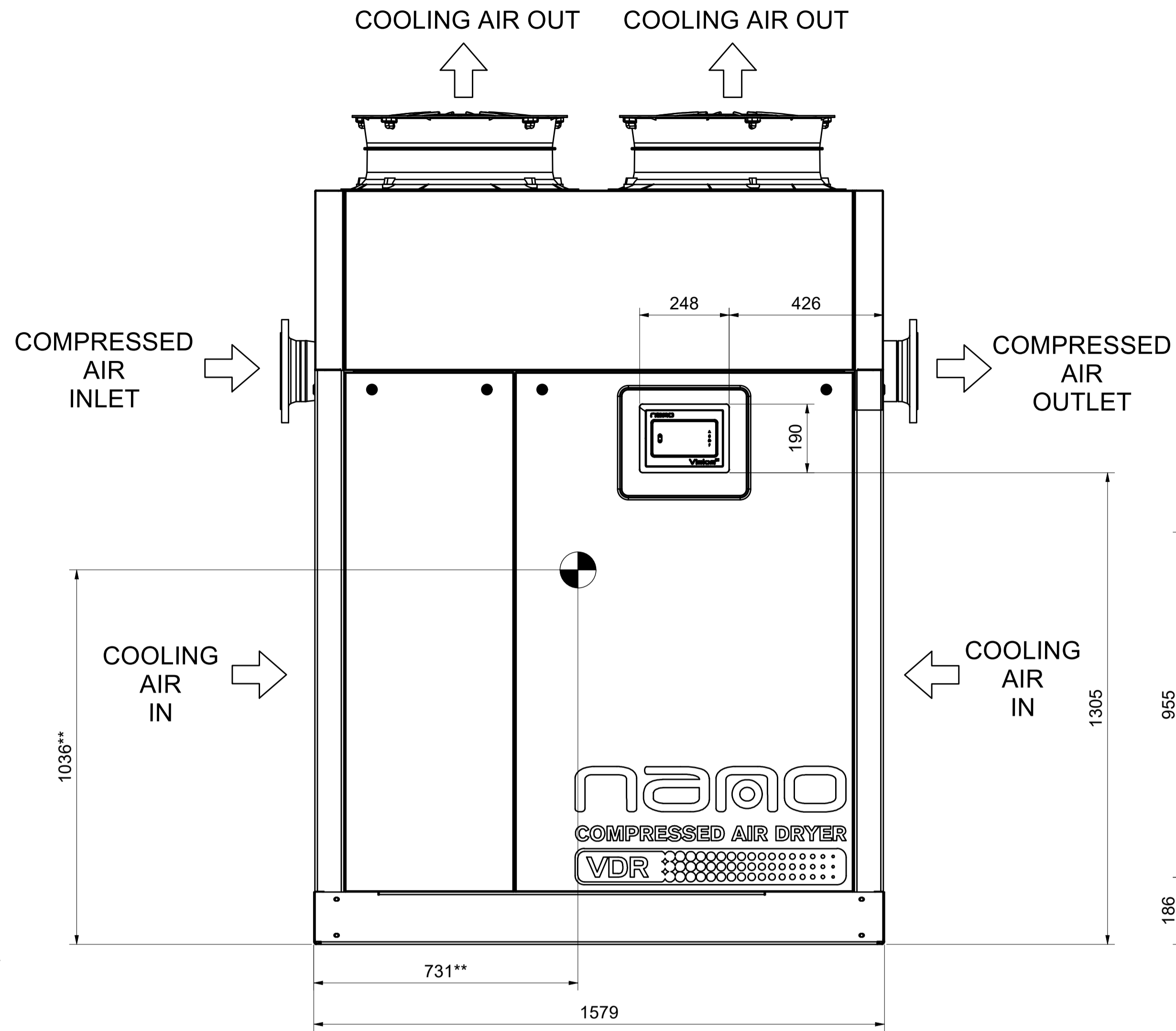

SIDE VIEW

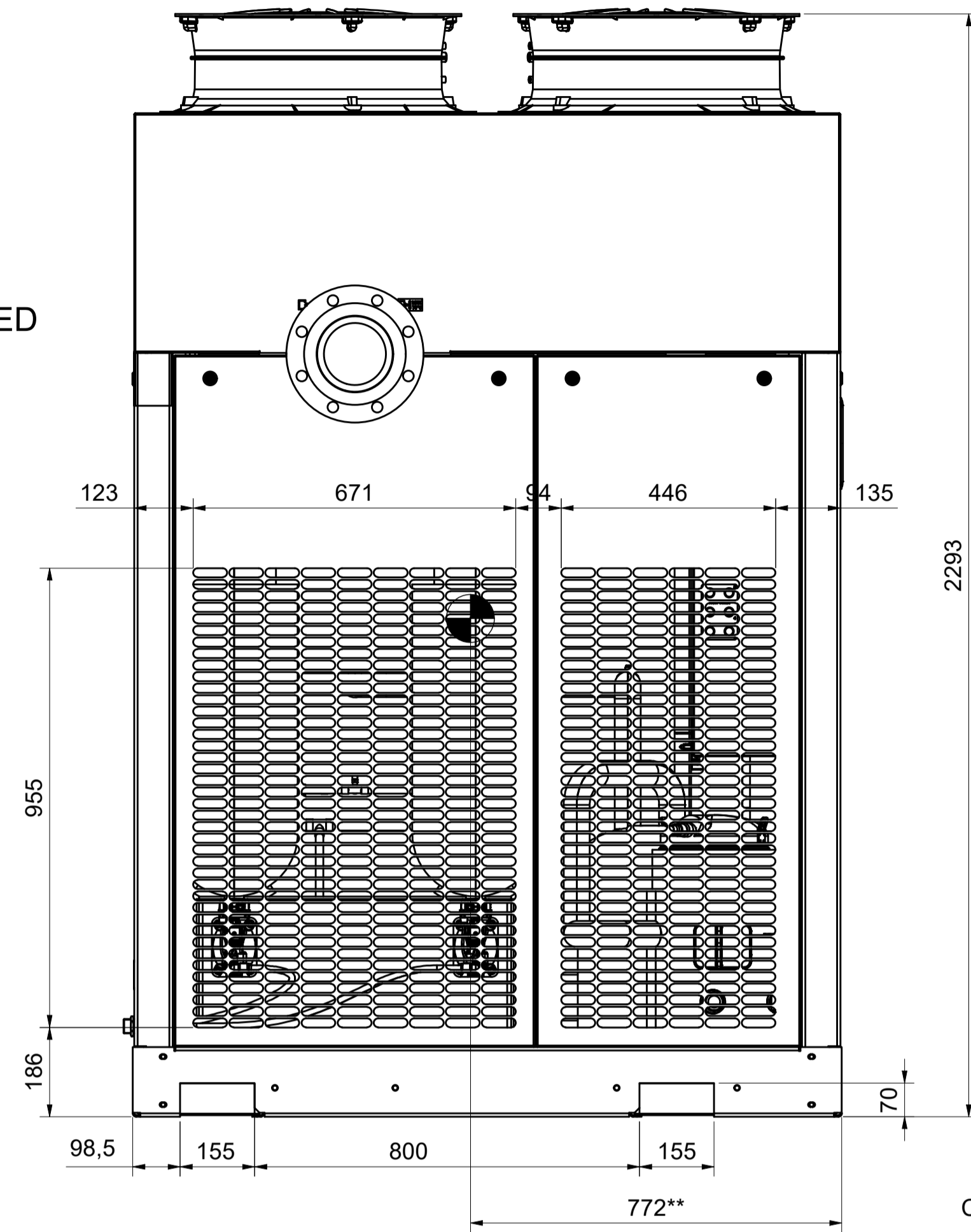

REAR VIEW

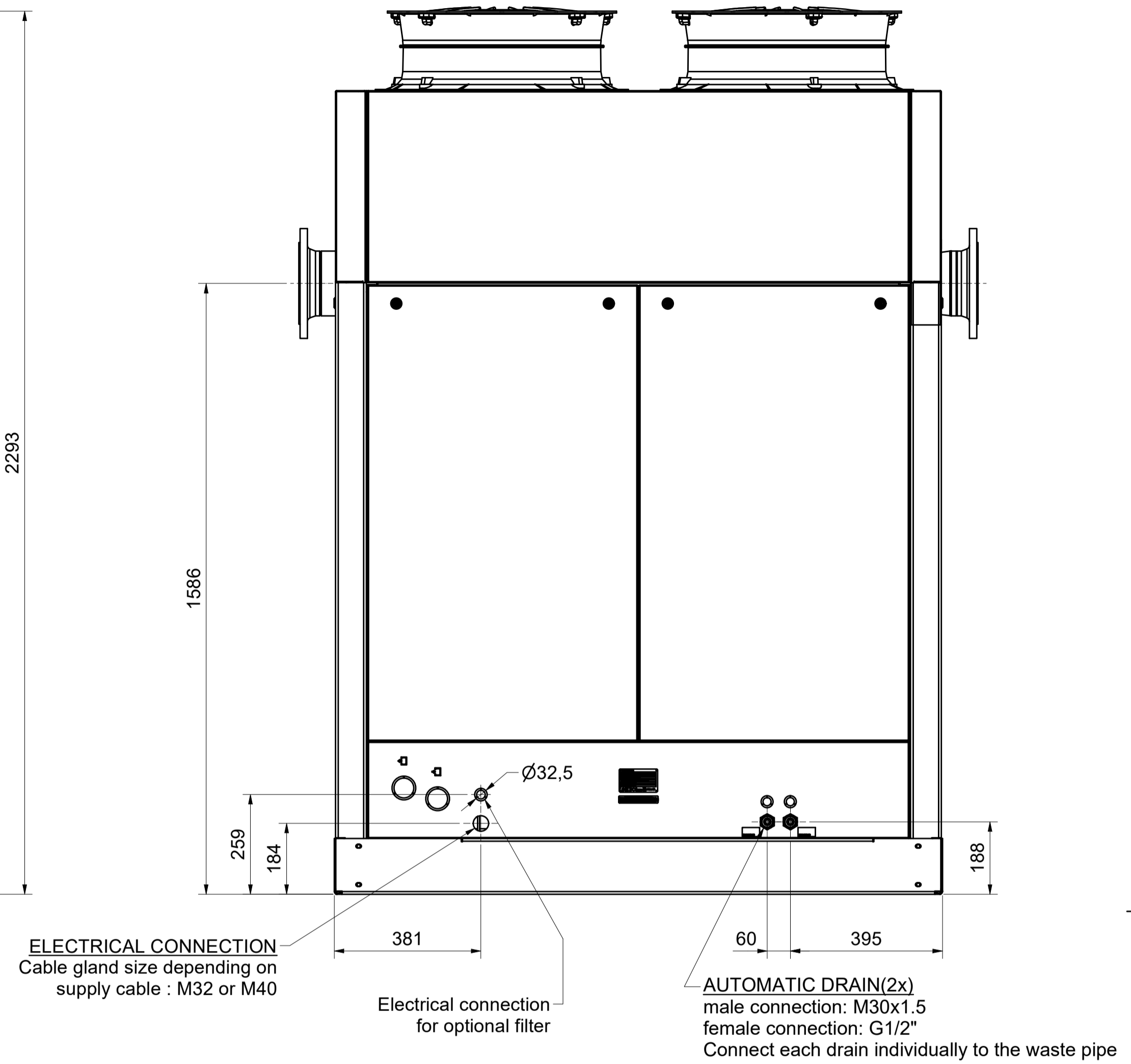

TOP VIEW

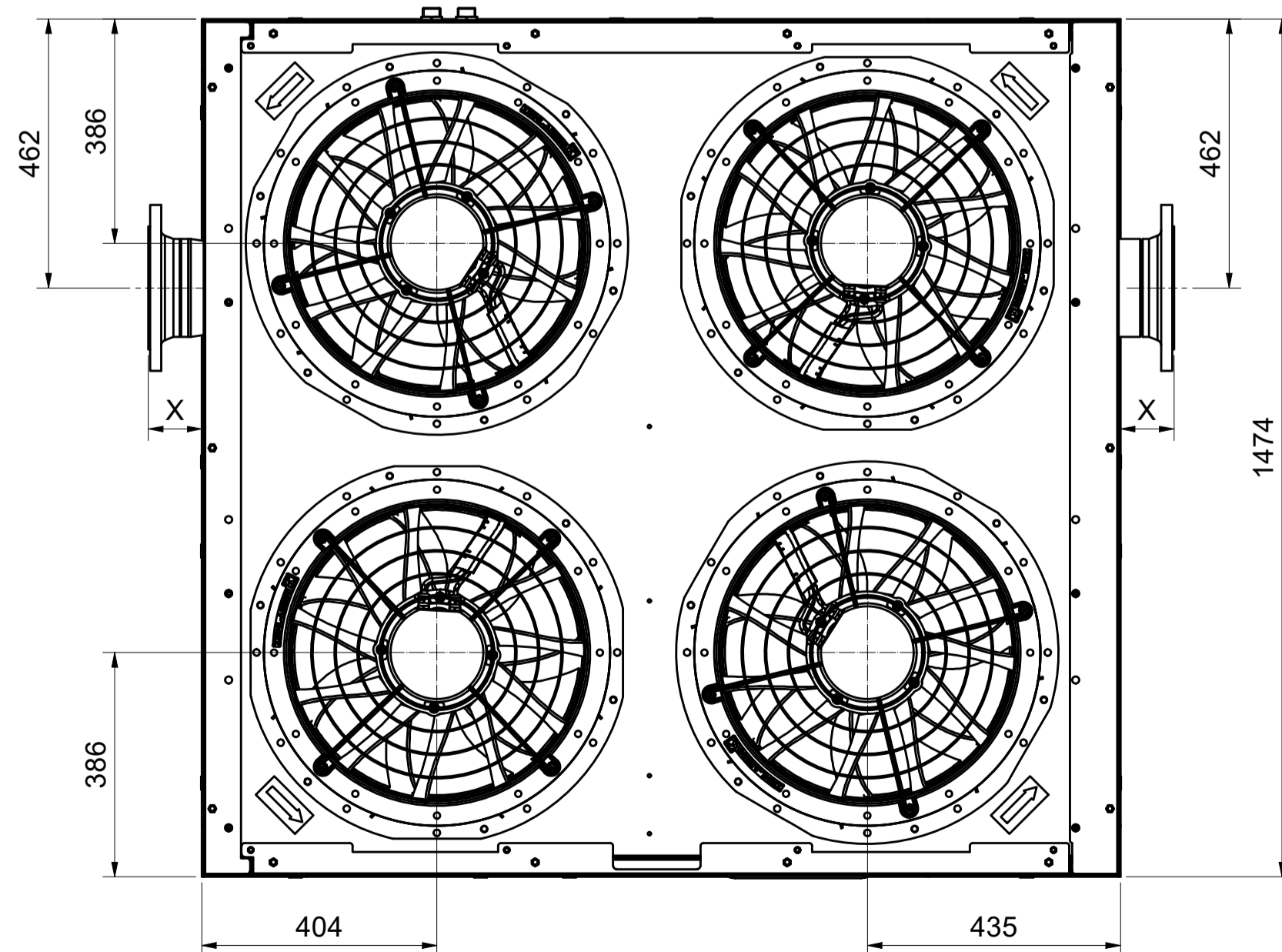

ANSI FLANGE (Zinc Plated)
(1 : 5)

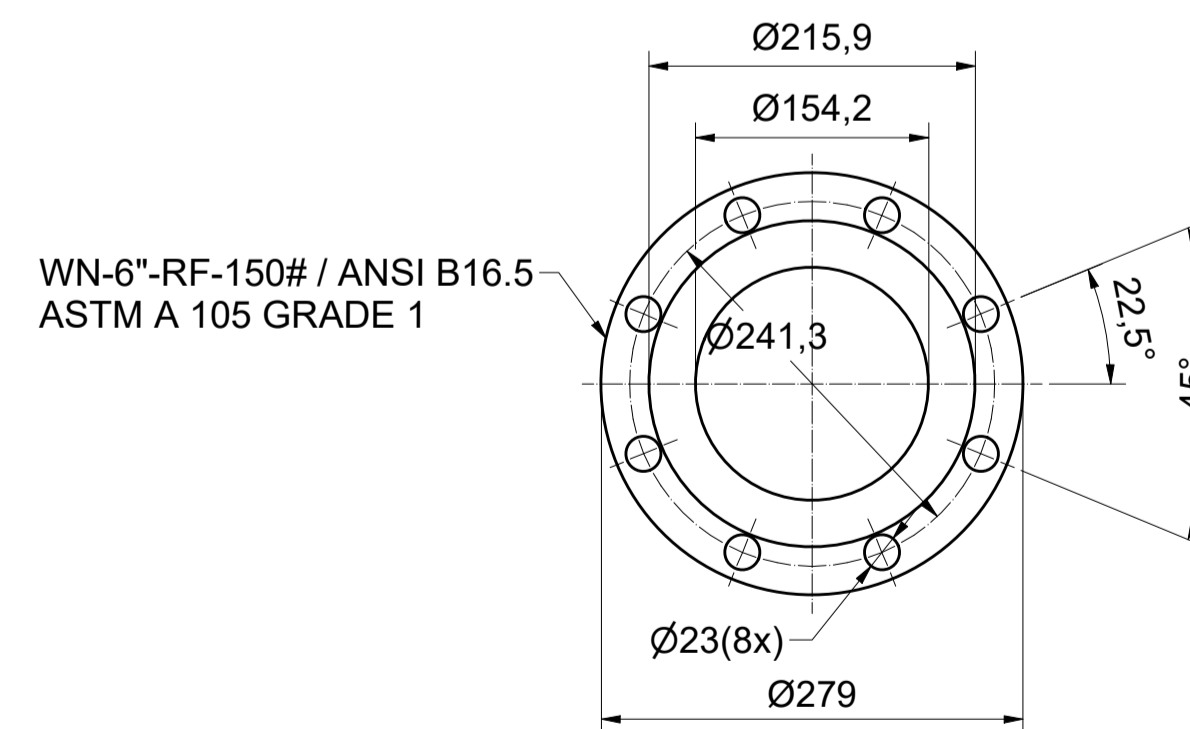

DIN FLANGE (Zinc Plated)
(1 : 5)

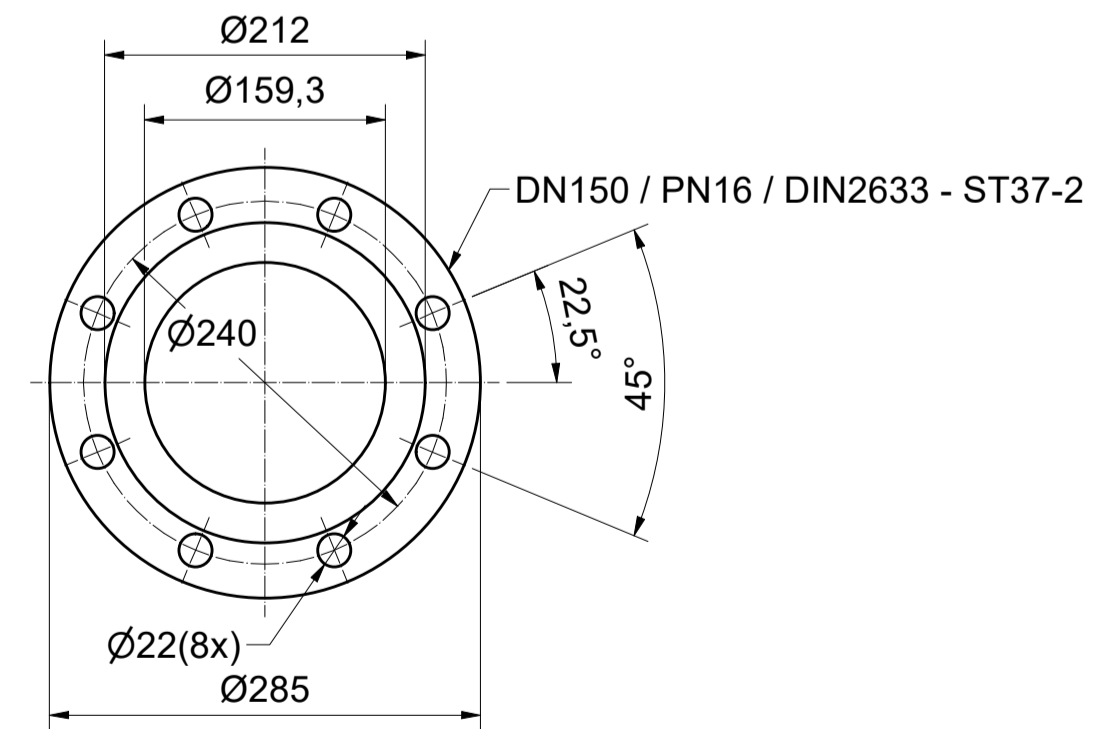

**CENTER OF GRAVITY (APPROXIMATELY)

Dryer Type / Ambient Version	Weight	X DIN FLANGE	X ANSI FLANGE	Fans
VDR2600 / 46°C	880 kg	92 mm	126 mm	4
VDR3150 / 46°C	935 kg	92 mm	126 mm	4
VDR3700 / 46°C	985 kg	92 mm	126 mm	4
VDR4200 / 46°C	990 kg	92 mm	126 mm	4
VDR5050 / 40°C	990 kg	92 mm	126 mm	4

Tolerances, if not indicated, according to:			
STANDARD CLASS			
Name	DIMENS. DRWG	VDR 2600-5050	Confidentiality Class acc. to 1102 K
Material	Not applicable		Internal
Treatment	Not Applicable		INV
Scale	1 : 10	Family	A1 Compare
Drawn by	INEMSI	Blank nr.	Replaces
Version Drwg		Kg Fini wt.	4034.251 kg
Designation		Date	13/12/2021
STATUS	Released	Des checked.	Prod checked.
Parent 3D model	Ed - Version 3D	Approved.	1839007680-01

CONFIDENTIAL: This document is our property and shall not be used without our prior permission. No part of this document may be reproduced, stored in a retrieval system, or transmitted in any form or by any means, electronic, mechanical, photocopying, recording, or by any information storage and retrieval system, without the prior written permission of INEMSI.

1				25/02/2022	User Agent
Ed	Position	Modified from	Date	Intr./Appd.	

1839007680-M1	1
Parent 3D model	Ed - Version 3D

All materials supplied are in compliance with the requirements of the List of Prohibited Substances

ANCHOR PADS

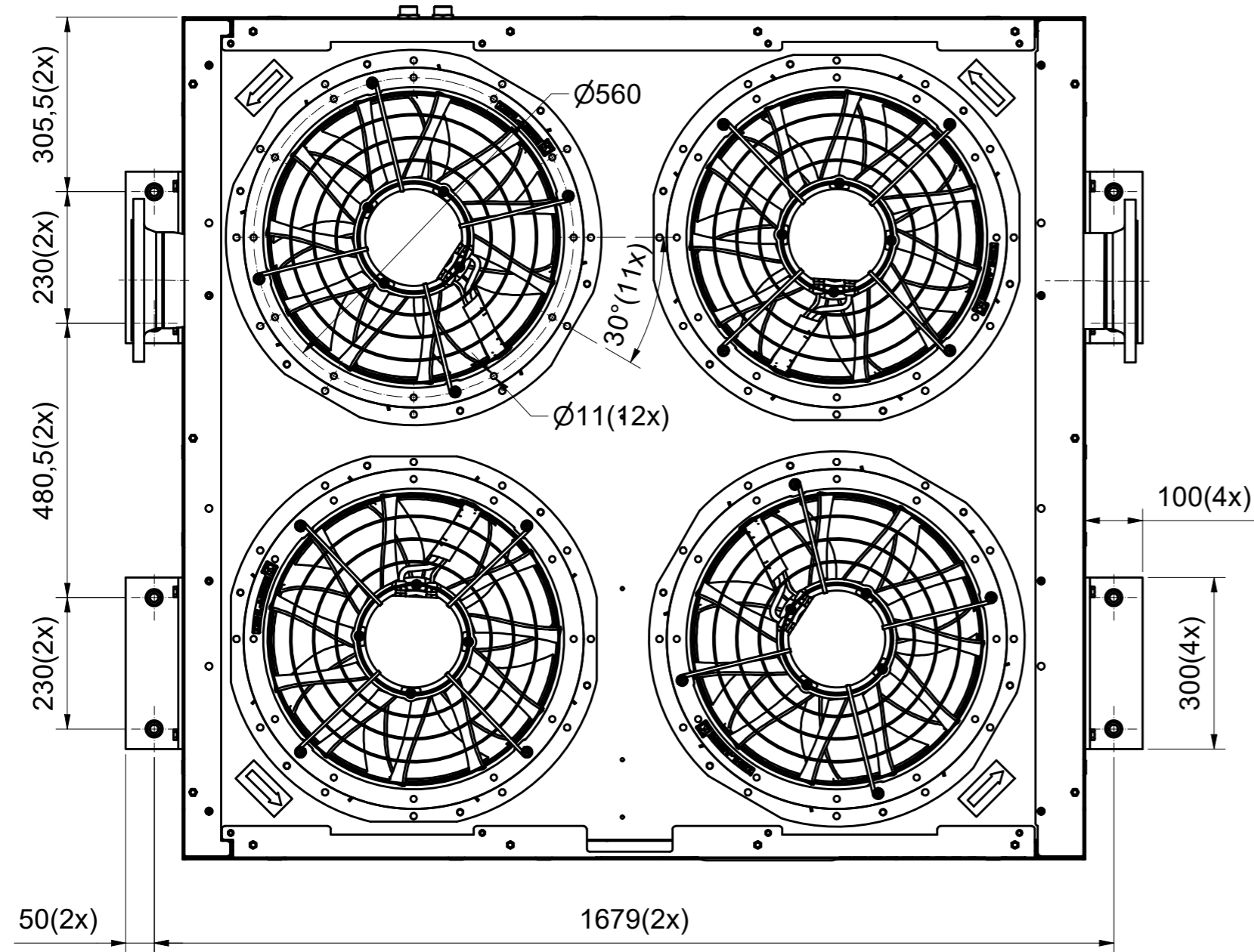

DUCTING CONNECTIONS

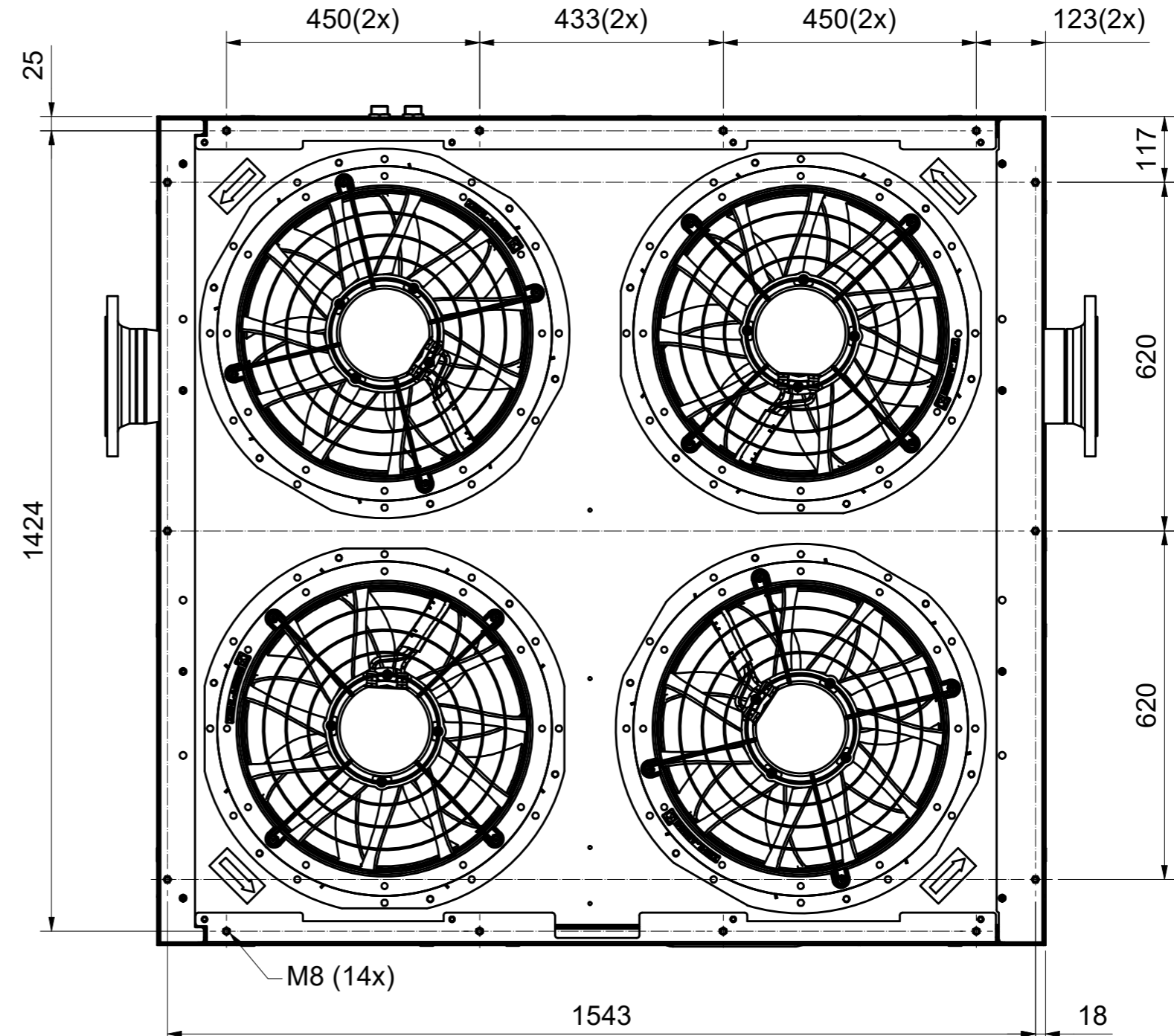

ANCHOR KIT (1:5)

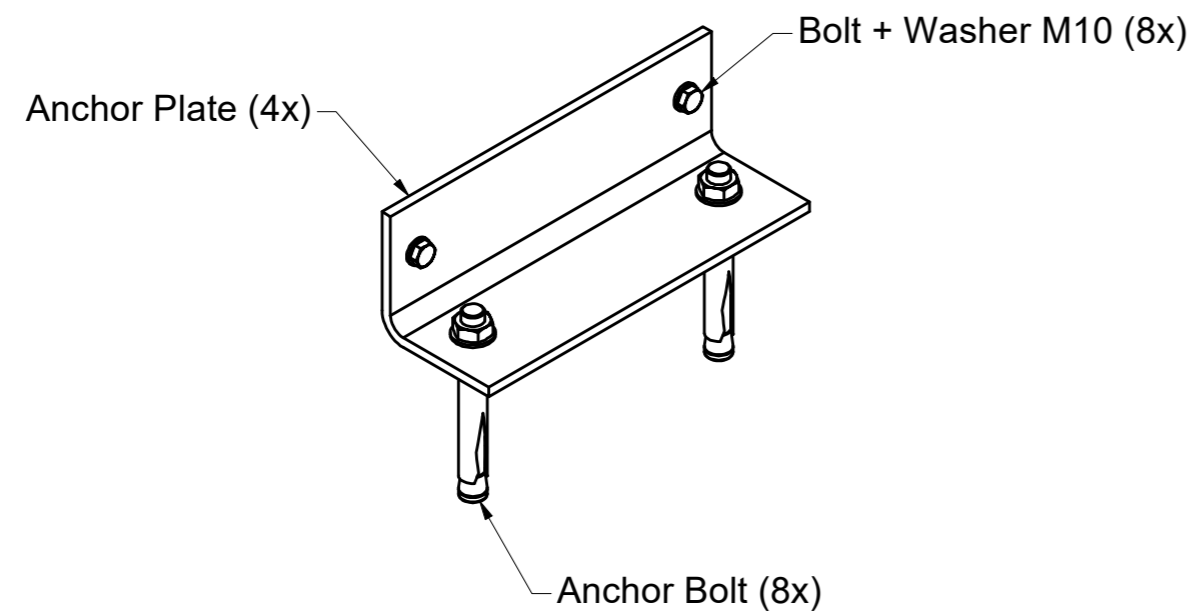

ANCHOR BOLT (1:2)

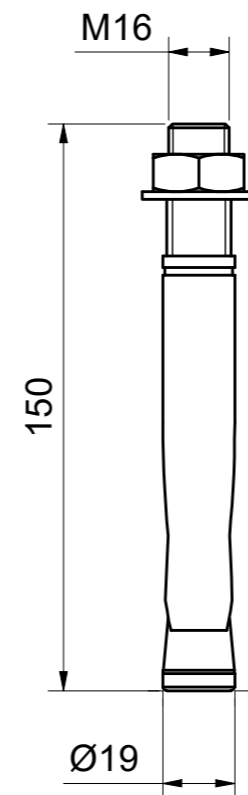

CONFIDENTIAL: This document is our property and shall not without our permission be altered, copied, used for manufacturing or communicated to any other person or company.

1			25/02/2022	User Agent
Ed	Position	Modified from	Date	Intr./Appd.

1839007680-M1	1
Parent 3D model	Ed. Version 3D

Tolerances, if not indicated, according to:							
STANDARD CLASS							
Name		DIMENS. DRWG		VDR 2600-5050		Confidentiality Class acc. to 1102 K	
Material		Not applicable		Internal		INV	
Treatment		Not Applicable		INV		Drawing owner	
Scale		1:10		Family		A2 Compare	
Drawn by		INEMSI		Blank nr.		Replaces	
Version Drwg		Blank wt		Kg		Fini wt. 4034.251 kg	
STATUS		Des checked.		Prod checked.		Approved.	
Released				Date		13/12/2021	
Designation						1839007680-01	
						Sheet 3 / 3	

A
B
C
D
E
F
G