

All materials supplied are in compliance with the requirements of the List of Prohibited Substances

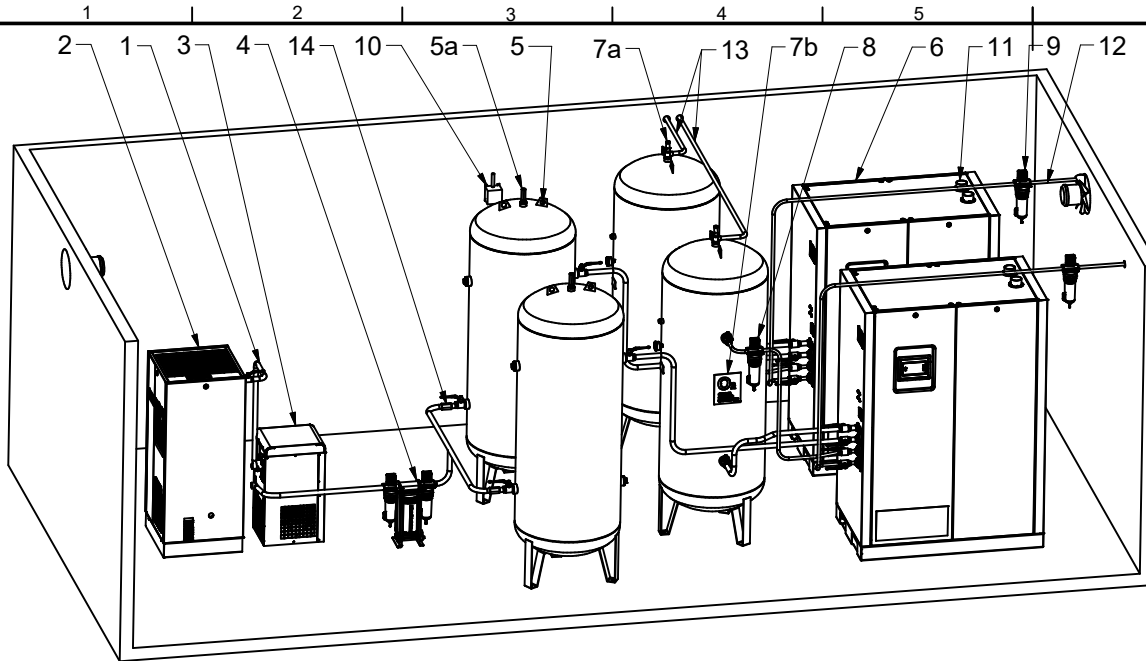

Legend	
1	Piping
2	Compressor
3	Dryer
4	Filtration
5	Air tank
5a	Safety valve
6	Oxygen generator
7	Product tank
7a	Oxygen safety valve
7b	Oxygen tank label
8	Oxygen filter
9	Oxygen filter anti-bacterial (optional)
10	Room oxygen sensor (optional)
11	Waste exhaust
12	Oxygen outlet to customer or storage tank
13	Oxygen safety valve exhaust pipe
14	Check valve

Pipe Connections

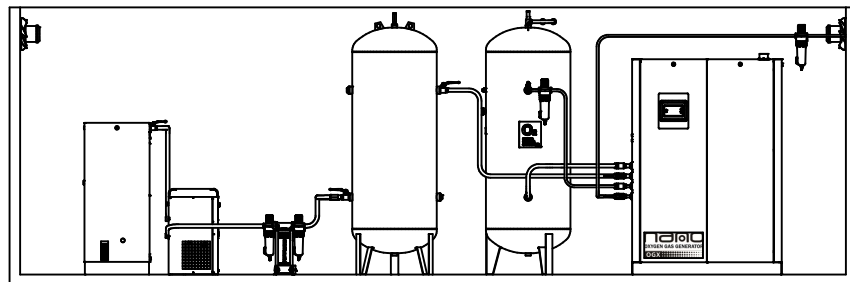
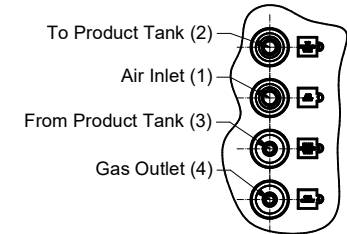

Min 600      Min 600

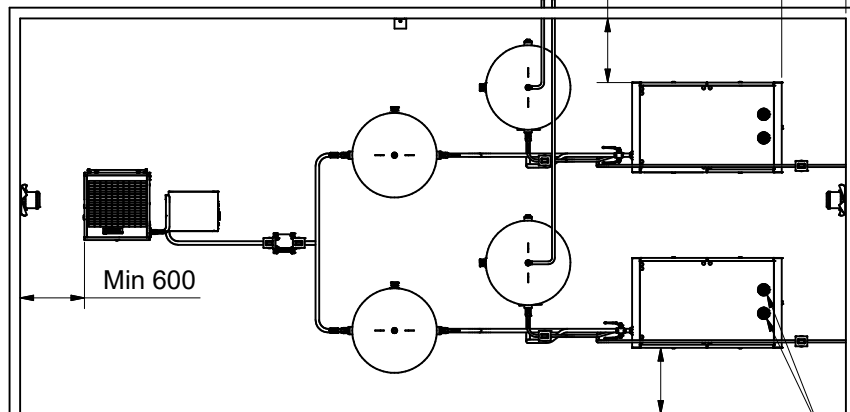

Min 600      Waste Exhaust (5)

Notes:

- Consult the attached step by step instructions 9828530066-03 for further details.
- Inlet air requirement according to ISO 85731:2010 class 1-4-1.
- Diameter of pipe connections in table overview valid up to 5 meters pipe length.
- All equipment must be installed on a level floor suitable for taking the weight of the equipment.
- Allow a free space of minimum 600mm around the equipment.
- Isolate equipment and tanks by means of ball valves.

Tank sizes and pipe connections

MODEL	OGX110	OGX220	OGX330	OGX440	OGX550	OGX640	OGX850	OGX1070
AIR TANK VSD IN LITERS (GALLON)	270(45)	270(85)	500(130)	500(170)	1000(215)	1000(255)	1500(340)	2000(430)
AIR TANK FIXED SPEED IN LITERS (GALLON)	270(60)	500(120)	500(180)	1000(240)	1000(300)	1500(360)	2000(480)	3000(600)
PRODUCT TANK IN LITERS (GALLON)	270(45)	270(85)	500(130)	500(170)	1000(215)	1000(255)	1500(340)	2000(430)
2: TO PRODUCT TANK	G1/2"	G1/2"	G1"	G1"	G1"	G1 1/4"	G1 1/4"	G1 1/4"
1: AIR INLET	G1/2"	G1/2"	G1"	G1"	G1"	G1 1/4"	G1 1/4"	G1 1/4"
3: FROM PRODUCT TANK	G1/4"	G1/4"	G1/2"	G1/2"	G1/2"	G1/2"	G1/2"	G1/2"
4: GAS OUTLET	G1/4"	G1/4"	G1/2"	G1/2"	G1/2"	G1/2"	G1/2"	G1/2"
5: WASTE EXHAUST	Ø80mm	Ø80mm	2xØ80mm	2xØ80mm	2xØ80mm	3xØ80mm	3xØ80mm	3xØ80mm

Tolerances, if not indicated, according to:

STANDARD CLASS

Name DIMENS. INSTALL.

PARALLEL OGX GENERATORS

Confidentiality Class acc. to 1102 K Internal INV

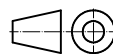

Material Not applicable

Treatment Not Applicable



Scale 1 : 50

Family

A3 Compare

Drawing owner

Drawn by INEBM

Blank nr.

Replaces

API

Version Drwg

Blank wt.

Kg Fini wt.

Designation

Sheet 1 / 1

Des checked.

Prod checked.

Approved.

Date

27/07/2022

9828530066-02

1					9828530066-M1	02.01	
Ed	Position	Modified from	Date	Intr./Appd.	Parent 3D model	Ed . Version 3D	STATUS
							Released

CONFIDENTIAL:

This document is our property and shall not without our permission be altered, copied, used for manufacturing or communicated to any other person or company.