



Installation and Operation Manual

Installation, Operation, and Service Information

Aircel AXHP Series Non-Cycling Refrigerated Air Dryer

Models: AXHP-20, 30, 40, 60, 100, 125, 200, 275



Throughout this manual, signal words are present to advise of safety precautions and/or standard practices.

Obey these signal words as defined below:

DANGER! - indicates an imminently hazardous situation which, if not avoided, will result in death or serious injury.

WARNING! - indicates a potentially hazardous situation which, if not avoided, could result in death or serious injury.

CAUTION! - indicates a potentially hazardous situation which, if not avoided, may result in minor or moderate injury.

Notice: - used to address practices not related to personal injury.

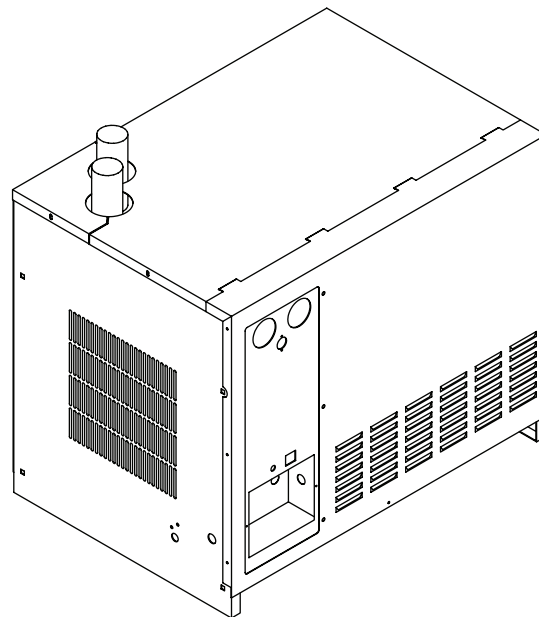

This manual is property of the owner, and should be left with the unit when start-up is complete. Aircel LLC. reserves the right to change design and specifications without prior notice.



WARNING!

General Safety Procedures

- Improper installation, operation, or maintenance may contribute to conditions in the work area or facility that could result in personal injury and product or property damage. Check that all equipment is properly selected and sized for the intended use.
- Consult and comply with national and local codes relating to fire or explosion and all other appropriate codes when determining the location and operation of this equipment.
- Safe and efficient operation of the unit depends on proper installation.
- Authorities with jurisdiction should be consulted before installing to verify local codes and installation procedures. In the absence of such codes, install unit according to the National Electric Code, NFPA No. 70-latest edition.
- A qualified installation and service agent must complete installation and service of this equipment.
- DO NOT weld on / to pressure vessel or modify it in any way.
- DO NOT remove, modify, or adjust protective or safety devices.
- Lock out power supply and depressurize system before performing maintenance or service work.
- DO NOT operate the equipment with the control panel door open.

Notice: For optimum performance, use only Aircel replacement parts.

Notice: For optimum performance, use only original equipment replacement parts.

Notice: For information and notes specific to a custom designed and built dryer, reference the drawing package provided with the unit. See warranty on manual back cover for custom engineered products.

Contents

Safety Statements	2	Shut-Down Procedures.....	16
Data Sheet.....	4	Shut-Down Emergency.....	16
Refrigerant Safety Precautions	5	Short-Term Shut-Down.....	16
Design Parameters.....	6	Service Information.....	17
Description.....	6	Maintenance.....	17
System.....	6	Troubleshooting.....	19
Refrigeration Circuit	7	Electrical	19
Compressed Air Circuit.....	7	Refrigeration	19
Purpose and Intended Use.....	9	Condensate Removal.....	20
Inspection on Arrival	9	Other.....	20
Lifting Information	10	Troubleshooting Table.....	21
Installation Codes and Procedures	10	Appendix	26
Installation	11	R-134A Refrigerant MSDS.....	26
Typical Installation	12	R-404A Refrigerant MSDS.....	31
Preliminary Start-Up Checklist.....	12	Wiring Diagram	38
Automatic Drain Valve Adjustments.....	14	Service Notes	45
Operating Procedure	14	Warranty.....	48
Air Cooled Condenser Requirements	14		
Cooling Water Requirements.....	15		
Water Cooled Condenser Table	15		



This manual contains specific precautionary statements relative to worker safety. Read thoroughly and comply as directed. Discuss the use and application of this equipment with a representative. Instruct all personnel on safe use and maintenance procedures. Understand and obey the following signal words used in this manual.

- **DANGER!** - indicates an imminently hazardous situation which, if not avoided, will result in death or serious injury.
- **WARNING!** - indicates a potentially hazardous situation which, if not avoided, could result in death or serious injury.
- **CAUTION!** - indicates a potentially hazardous situation which, if not avoided, may result in minor or moderate injury.
- **Notice:** - used to address practices not related to personal injury.

Data Sheet

Model Number _____ Serial Number _____

Date of Manufacture _____

Ship Date _____ Installation Date _____

Customer Name

Address _____

Accessories _____

Other _____

Refrigerant Safety Precautions



CAUTION!

Inhalation, Skin, & Eye Irritant

- Use proper safety and protective equipment, including chemical safety goggles or face shield and impervious gloves when handling refrigerants.
- Exercise care to ensure that liquid refrigerant does not come in contact with your skin or eyes.
- DO NOT SMOKE.
- Ventilation in work area must be adequate to keep the concentration of refrigerant below 1,000 ppm.
- System must be free of all refrigerant before any welding or brazing can be performed and must be done in a well ventilated area.
- Decomposition of refrigerants is hazardous! This material can be decomposed by high temperatures caused by an open flame. Hydrofluoric acid and possibly carbonyl fluoride can form in a liquid or gaseous state. Avoid exposure to these toxic fumes and irritating materials.
- Leave the work area immediately if you experience any of the following: smell something unusual, feel light-headed, experience shortness of breath, feel a tingling sensation in your fingers or toes, suddenly feel warm or a rapid heartbeat.

Refrigerant First Aid Recommendations

Inhalation

If high concentrations are inhaled, immediately remove individual from affected area to an area with a fresh air supply. Keep individual calm. If not breathing, give artificial respiration or if having difficulty breathing, give oxygen and call for emergency services.

Skin Contact

In case of contact with the skin, immediately flush skin with clean water for at least 15 minutes. Treat for frostbite if necessary by gently warming affected areas and call for emergency services. Remove any contaminated clothing or shoes.

Eye Contact

In case of contact with the eyes, immediately flush eye(s) with clean water for at least 15 minutes and call for emergency services.

Design Parameters

Type of dryer: Refrigerated

Power supply: 115, 230, 460 Volt / single or three phase / 60Hz

Refrigerant.type: R-134A
R-404A

Chemical Composition: HFC

	Parameter Description	Optimum	Maximum	Minimum
All Models	Air Pressure (psig)	100-125	*See Data Label	225
	Air Inlet Temperature (°F)	80-100	140	40
	Ambient Temperature (°F)	75	120	35
	Evaporation Temperature (°F)	35-42	60	33
R-134A	Suction Gauge Reading (psig)	28-40	60	28
	Discharge Gauge Reading (psig)	160-230	260	80
R-404A	Suction Gauge Reading (psig)	75-90	130	75
	Discharge Gauge Reading (psig)	290-400	450	160

Description

System

The non-cycling refrigerated air dryer product covers the flow range listed on the manual front cover and provides reliable dew point performance in most flow conditions. Through optimization of critical dryer components – heat exchanger, separator, and condensate removal – the system ensures the highest performance at full- and partial-load conditions. R-134a refrigerant is used in dryer models AR-45 through AR-1000 while R-404A is used in the AR-1400 and higher models. R-134a is a pure refrigerant providing consistent performance (zero temperature glide) and easy service (no mixture of different refrigerants). R-404A is a blend of three pure refrigerants: 52% R-143A, 44% R-125, and 4% R134A (by mass). This blend is nearly azeotropic meaning it has a negligible temperature glide. R404A is well suited to larger equipment as the higher operating pressures

and improved heat transfer properties allow for smaller condensers, which leads to air dryers with smaller footprints.

Hot saturated air enters the air-to-air heat exchanger of the Non-Cycling Refrigerated Air Dryer and is pre-cooled by the outgoing dry air. Pre-cooling saves energy by reducing the heat load on the dryer’s compressor. The cool saturated air enters the air-to-refrigerant heat exchanger where air temperature is lowered to the 38 to 42°F range. This dramatic temperature drop condenses water and oil.

The mixture of cold air and condensation then flows into the two-stage separator filter where liquids and contaminants are removed by centrifugal action, directional flow change, and velocity reduction. Once bulk liquids have been removed, the compressed air goes through a stainless steel mist eliminating filter that coalesces oil aerosols and oil vapors within the 100-micron range, and then separates and removes them. At this point, the compressed air is dry and virtually oil-free.

Cold, dry air exits through the pre-cooler heat exchanger and is reheated by incoming hot air. Reheating restores energy and also prevents condensation from forming on the outside of air distribution piping. In the refrigeration unit, the compressor pumps hot, high-pressure gaseous refrigerant to the condenser where it is cooled and liquefied by ambient air. From the condenser, liquid refrigerant first flowsthrough the receiver, then through a filter/dryer, and finally through the expansion valve where pressure and temperature are reduced. This reduction in pressure causes the liquid refrigerant to boil until it reaches the saturation temperature that corresponds to its pressure. As the low-pressure refrigerant passes through the evaporator, heat flows from the compressed air to the refrigerant, causing the boiling to continue until all refrigerant is vaporized. Refrigerant gas is returned to the compressor and the cycle is repeated. A hot gas by-pass valve is used to control temperature in the evaporator.

Refrigeration Circuit

Refrigerant is compressed by the compressor to a gas with high temperature and high pressure, which then travels to the condenser (air or water cooled) to condense the gas into a liquid. Liquid travels to the evaporator (refrigerant-to-air part of the heat exchanger) and back to the compressor suction side. The process then repeats. A thermal expansion hot gas by-pass valve is used on the non-cycling dryers as a freeze protector in low load conditions ([1-1/4 HP] and up).

Compressed Air Circuit

The compressed air dryer circuit uses a patented air-to-air heat exchanger, which acts as a pre-cooler/reheater. Hot, saturated, compressed air first enters the air-to-air heat exchanger, where it is pre-cooled by outgoing air from the air-to-refrigerant heat

exchanger. This energy saving heat exchanger provides several advantages, such as a reduction of the heat load imposed on the refrigerant compressor and condenser, providing more energy to the outlet air, and preventing condensation of moisture on the outside of the plant distribution air line piping. From the air-to-air heat exchanger, air will enter into the evaporator further reducing its temperature to a desired pressure dew point. As the air is cooled, moisture is condensed, separated, and discharged through the condensate drain. The cooled air then reenters the air-to-air heat exchanger, in a direction opposite to the flow of the warm, saturated incoming air. This counter flow action assures high temperature differential throughout the heat exchanger, resulting in a more effective heat transfer.

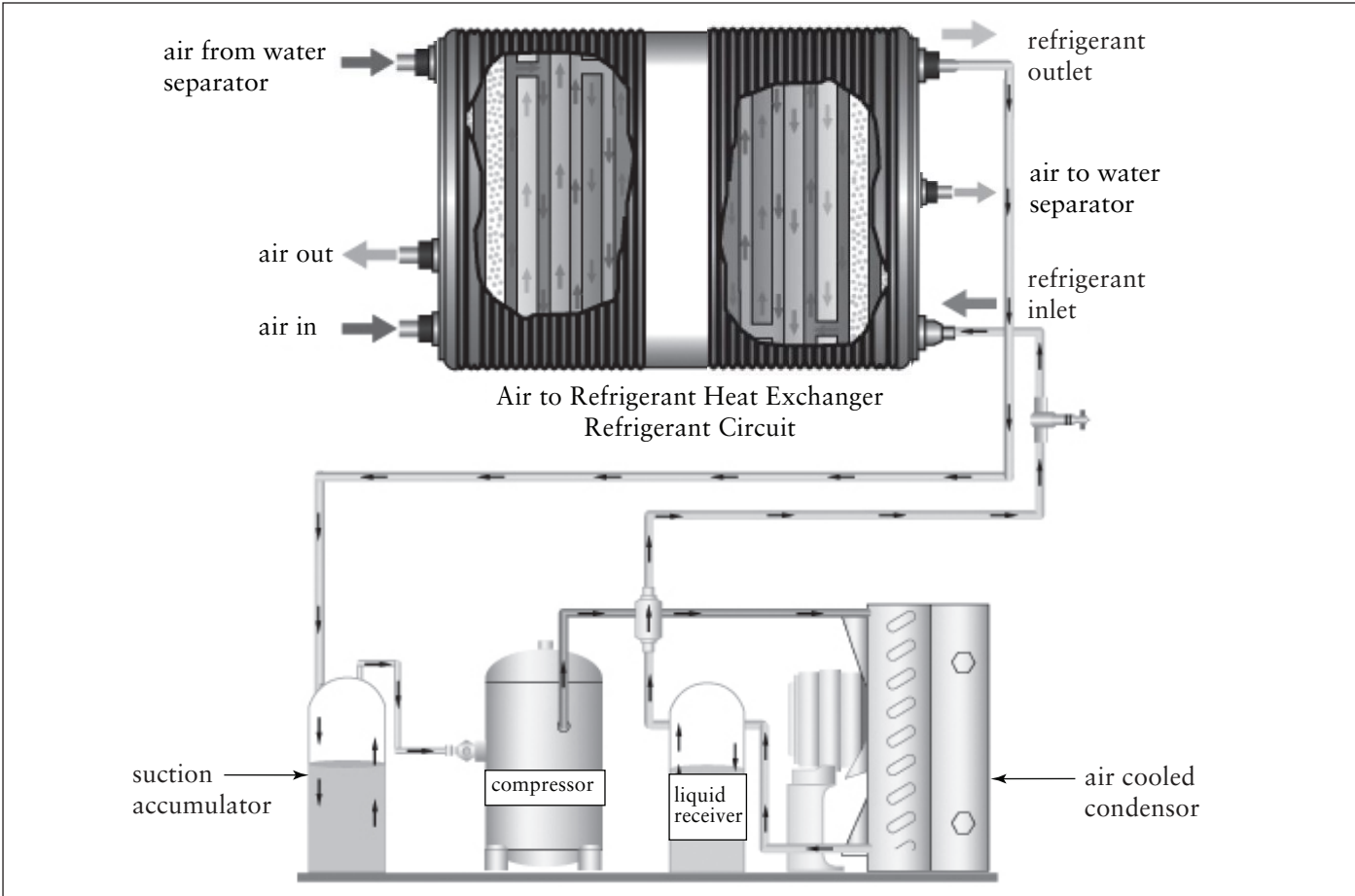

Typical Schematic Flow Diagram

Purpose and Intended Use

Non-cycling refrigerated air dryers are designed to remove moisture from compressed air by use of mechanical refrigeration. They can provide pressure dew points as low as (38° F- 42° F). Refrigerated dryers are used to protect industrial compressed air systems, machinery, and tools. To ensure maximum performance and safe operation of this dryer, everyone associated with its installation, operation, and maintenance must read, understand, and follow the instructions of this manual.

**CAUTION!**

- Do not misuse or modify under any conditions. Misuse or modification of this equipment may result in personal injury.

Inspection on Arrival

All non-cycling refrigerated air dryers are tested and operated before shipment. However, shipping stresses have the potential to cause damage to the unit. To ensure smooth installation, it is recommended that immediately upon receipt of the unit, the system is checked for the following:

1. Report any damage to the delivery carrier.
2. Request a written inspection report from the Claims Inspector to substantiate the claim.
3. File claims with the delivery carrier.
4. Compare unit received with description of product ordered. Check the serial plate label and make sure that it is the correct Model was ordered. Note the equipment Capacity and Power Supply requirements and ensure that they are in accordance with your specifications. The rated conditions of the dryer are indicated on the serial plate label. If there is any discrepancy, contact your representative listed on the manual back cover.
5. Shipping stresses can loosen connections. All pipe and tubing connections should be inspected.
6. Observe pressure of refrigerant suction gauge to determine if refrigerant has leaked during transit. If the gauge reading does not match that mentioned on the serial plate label, immediately contact Technical Support listed on the manual back cover.
7. Report incomplete shipments to the delivery carrier and your service representative.

Lifting Information

1. Use all lifting points provided. Special care must be used when lifting the dryer to prevent tip-over.
2. Use clevis connectors, not hooks, on lifting slings.
3. Only lift unit under support frame/base by using the fork lift openings provided. Do not lift by piping.
4. Check the approximate weight provided on the specification control drawing to ensure adequate lift truck capacity.
5. Allow only qualified operators to lift the equipment.
6. Refer to applicable OSHA regulations and local codes when using cranes, forklifts, and other lifting equipment.



WARNING!

- Failure to lift the unit correctly can result in severe personal injury or property damage.
- Use appropriate lifting equipment and adopt all safety precautions needed for moving and handling the equipment.
- A hand cart, forklift or crane is recommended for unloading and installation.
- Lift unit by lifting lugs and frame only. Do not lift by piping.

Installation Codes and Procedures



WARNING!

- Follow proper lock out/tag out procedures before performing service or maintenance work.
- Electrical installation must be performed by a qualified electrician and comply with all applicable national and local codes.

1. Safe and efficient operation of the unit depends on proper installation.
2. Authorities with jurisdiction should be consulted before installing to verify local codes and installation procedures. In the absence of such codes, install unit according to the National Electric Code and NFPA No. 70-latest edition.
3. A qualified installation and service agent versed in all regulatory codes must complete installation of this unit.



CAUTION!

- A copy of the Operation Manual must be made available to all personnel involved with the installation, operation and maintenance of the equipment, to avoid injury to personnel or property damage.
- Appropriate tools must be used for all installation and maintenance work, to avoid injury to personnel or property damage.

Installation

1. Locate unit on a level foundation. Dryer should be mounted on a suitably structured flat and level floor or base that is free from vibration.
2. Install unit to provide adequate clearance for maintenance services. Dryer and accompanying filters should be installed with at least 2 to 5 feet clearance from the adjoining walls to provide easy access for routine maintenance and adequate air flow across the condensing coil.
3. The frame or cabinet must be securely bolted to the foundation to prevent movement resulting from earth tremors and induced piping vibration.
4. Install unit using the correct pipe size and pressure rating. See drawing package provided with the unit. Connect the inlet of the dryer to the moist gas from the inlet filter. Install the inlet piping and the inlet shutoff valve. Install the outlet piping and the outlet shutoff valve (a union with a valve by-pass can be installed at the inlet and outlet valves to accommodate isolation of the dryer for maintenance).
Compressed air piping has to be at least the same size as that of the inlet and outlet connections of the dryer. Larger pipe sizes can be used with appropriately rated reducers.
Operation at elevated pressure or temperature may cause damage to the dryer or serious injury to personnel. Each dryer is checked at the factory for proper operation at the conditions noted on the serial plate label.
5. Provide adequate power supply. See Design Parameters section. Make all electrical connections to the dryer as shown on the wiring diagram. Special care must be taken in connecting the proper voltage as indicated on the specification sheet and wiring schematic. It is mandatory that the dryer be grounded. Use of your plant's frame as a ground may cause problems with the controls. A fused disconnect is not supplied with this equipment; therefore, one must be supplied by customer. All electrical fuses, breakers, etc. should be sized by a qualified electrician and comply with all applicable national and local codes. Our company is not liable for any code violations, component damage, downtime or consequential damage related to customer supplied electrical components and connections.
6. The ambient temperature should be between 45°F and 100°F. Low temperature could affect the dryer process and result in high outlet dew point. In conditions where the ambient drops below freezing, it is recommended that a heat trace be used for the equipment. This will ensure trouble-free operation during the winter months (the dew point of the outlet air will be consistent). *In some cases, a head pressure control valve may be needed. (optional)
7. Do not place the system in service until the above steps have been completed and that all ratings and specifications have been verified to match the requirements in the drawing package supplied with the unit.
8. If there are any changes in the operating conditions of the system from those published in this manual, contact Technical Support.

Typical Installation

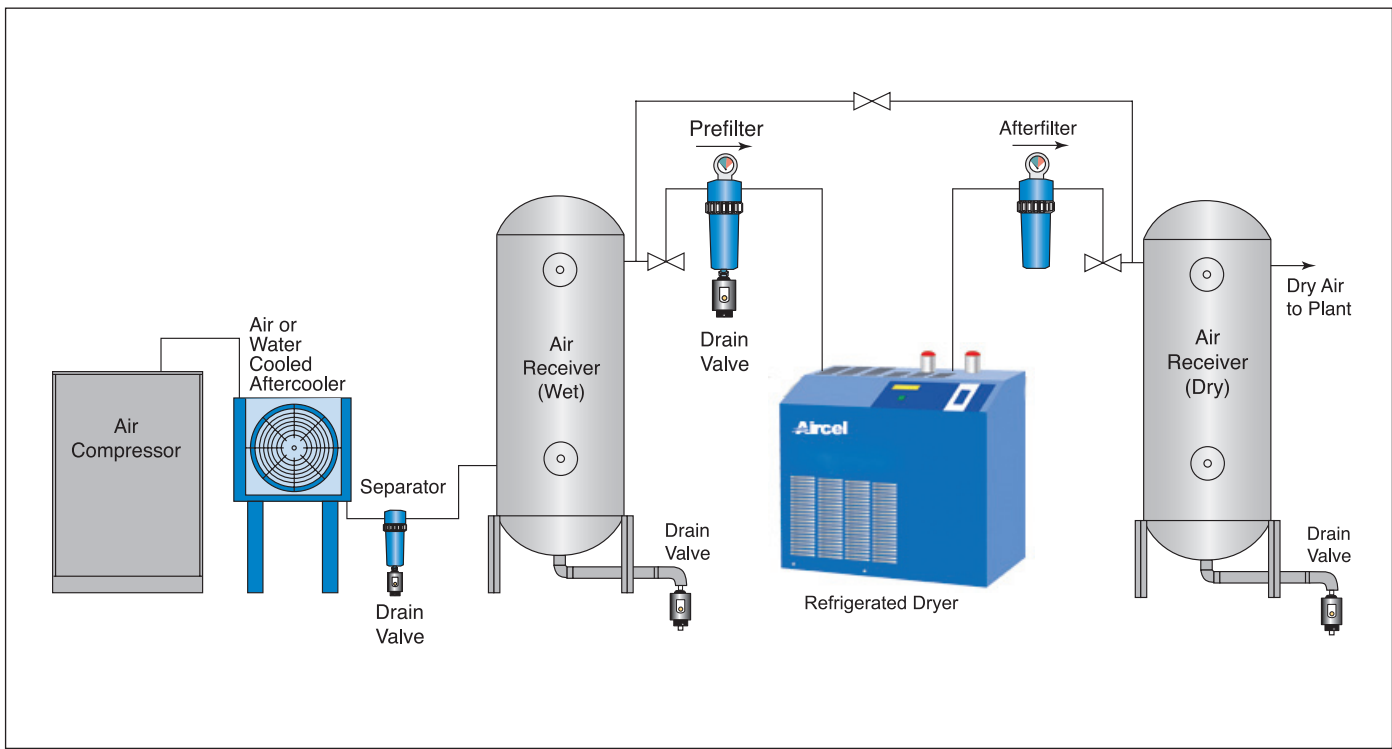

Typical Installation

Preliminary Start-Up Checklist

Notice: For scfm rated models 45 - 260, wait at least 6 hours after transporting or moving of dryer system before starting the dryers. Turn the main power switch to the dryer on, but do not turn the dryer on/off switch to the on position until 6 hours have passed.

For scfm rated models 415 and larger, ensure that the power switch is in the "off" position, but the electrical service to the dryer is energized. This dryer must be in this mode for at least twelve (12) hours to allow the compressor crankcase heater to energize and evaporate any liquid refrigerant from the compressor. After twelve (12) hours, turn ON the power switch of the dryer. The power indicating light should turn ON.

1. Check that the inlet and outlet connections are the correct size and pressure rating, and tightened securely.
2. Check that the correct power supply is connected to the non-cycling refrigerated air dryer system with an adequate disconnect switch.
3. Check that all compressed air line service valves are open and that compressed air is available to be supplied to the non-cycling refrigerated air dryer system.
4. Check that all liquid drain service valves are open. This is to ensure that any residual bulk condensate that may have accumulated in the compressed air lines is discharged immediately upon start up. These drains must be closed once system is brought on line for use. The drain valve on the refrigerated air dryer can be opened by pushing the test button located on the drain body.

5. With the customer-supplied compressed air to the system, OPEN the inlet valve slowly to gradually pressurize the system. Do not open valve too quickly. Opening valve and suddenly pressurizing the system can cause damage to the dryer heat exchanger and other components.
 6. Check the air system piping connections and dryer system connections for leaks at this time. Repair and retest any leaks.
 7. Verify that all instrumentation (pressure gauge/s) and drain air tubing fittings are tight.
 8. Ensure that the air system has come up to full pressure and has filled the dryer with compressed air. Before opening the outlet valve on the system and after the dryer has been started under no load, let the dryer run for at least fifteen (15) minutes to allow stabilization of the system. Verify the following:
 - a. The dryer is designed to run continually and should not be cycling on and off with the air compressor. The non-cycling operation of the dryer is controlled by an automatic expansion valve or a thermostatic expansion valve / hot gas by-pass valve. The valves will open and close automatically depending on the of heat load to the evaporator, thus maintaining the desired pressure dew point.
 - b. Check the inlet compressed air temperature and pressure to the dryer and verify that it meets the specified requirements.
 - c. Fan rotation, for dryers with an air-cooled condenser, rotation should be in accordance with the fan rotation shown on the details located on top and back of the condenser. Cooling air is drawn through the condenser coils. If the motor rotation is not correct, turn off the power switch and put the main power supply disconnect in the “off” position; lock and tag; check the wiring; correct the wire lead locations; recheck for correct rotation.
 - d. The refrigeration gauge readings should be as follows:
 - Refrigerant suction pressure:
R-134A = 28-40 psig
R-404A = 75-90 psig
 - Refrigerant discharge pressure:
R-134A = 160-230 psig
R-404A = 290-400 psig
- Notice: The above discharge pressures depend upon ambient temperature and can vary slightly according to temperature fluctuations.
9. After the preliminary start up checklist has been completed, the compressed air outlet valve on the dryer system can now be slowly opened to supply clean dry compressed air to the facility.
 10. After start-up and approximately one month of service, check that all piping and fittings are tight and free of leaks.
- Notices:
- Models with the hot gas by-pass valves and expansion valves are preset at the factory for the desired dew point. Do not adjust without consulting with the factory.*
 - The dryers are fully automatic and do not require any auxiliary controls.
- *Adjustments not authorized by the factory may void the warranty.

Automatic Drain Valve Adjustments

The automatic drain valve supplied is standard on the separator and should open regularly and discharge any accumulated water into the drain line. The period between openings varies with the dryer and operating conditions (electronic type). To minimize air losses, the timer should be adjusted to open the drain solenoid just long enough to discharge the accumulated condensate. The factory sets the automatic drains to open for 7 seconds about every 7 minutes. If more than two seconds of dry air comes out at the end of every discharge cycle, reduce the open time (seconds) or increase the interval of the discharge (minutes) to minimize air loss. If liquid is still being discharged when the discharge cycle stops, increase the open time (seconds) or shorten the interval of discharges (minutes) so it discharges more often.

Operating Procedure

After the initial startup, the dryer operation is completely automatic. To understand the details of the operation, see the flow diagram on pages 7 and 8.

Air Cooled Condenser Requirements

Cooling air must be drawn from a clean source to reduce dust and dirt accumulation on the condenser coils. Air temperature should not exceed 100°F (38°C).

Model by SCFM Rating	Refrigeration Hp	Cooling air flow (cfm)
HP-20	1/5	275
HP-30	1/4	300
HP-40	1/3	300
HP-60	1/2	350
HP-100	3/4	525
HP-125	1 1/4	750
HP-200	1 1/2	1250
HP-275	2	3000

Cooling Water Requirements (water cooled condensing units)

Cooling water is required for water-cooled refrigerant condensers. The user is responsible for piping the water to and from the condenser. The required water flow rate depends on the water temperature. A water-regulating valve (supplied with the dryer) automatically adjusts the flow to compensate for variation in water temperature,

water pressure, and dryer air load. The table below indicates the amount of cooling water required in gallons per minute (gpm) at given incoming temperatures for the condenser Hp size in each model. The refrigerant discharge pressure control will shut down the refrigerant compressor if cooling is inadequate.

Water Cooled Condenser Requirements Table

Model by SCFM Rating	Condenser Hp	Incoming Water Flow Rate Requirements (in gpm at different inlet water temperatures)			
		70°F	80°F	85°F	90°F
HP-20	1/4	1	1.25	1.5	CF
HP-30	1/3	1.5	1.9	2.25	CF
HP-40	1/2	2	2.5	3	CF
HP-60	3/4	3	3.75	4.5	CF
HP-100	1 1/4	4	5	6	CF
HP-125	1 1/2	7	8.75	10.5	CF
HP-200	2	10	12.5	15	CF
HP-275	3 1/2	12	15	18	CF

(CF) - Consult Factory

Notices:

- Water cooled condensers are pre-set at the factory for city water usage.
- Water regulating valve may need to be adjusted to other water supply conditions. Contact technical support for assistance.
- Minimum water pressure is 25 psig for city water and 35 psig for tower water. Cooling water pressures less than these minimums may reduce dryer drying capacity.
- Maximum water pressure is 125 – 150 psig.

Shut-Down Procedures



WARNING!

- To avoid possible hazard or injury, the operator should be fully familiar with the refrigerated air dryer system and its operation.
- When the system is shutdown and power removed, lock out power supply and depressurize system before performing maintenance or service work to avoid injury to personnel or property damage.

Shut-Down Emergency

The non-cycling refrigerated air dryer system can be shut down under any conditions and at any time by turning the unit off at the dryer or at the main disconnect switch. Once power is removed from the dryer system, the dryer must be isolated from the compressed air stream to avoid a refrigeration circuit over pressure situation.

Short-Term Shut-Down (over night or weekends)

The refrigerated air dryer system can be shut down at any time by turning the unit off at the dryer by using the on/off switch or at the main disconnect switch.

Service Information

To reach a field service technician or for technical support, please call the number on the manual back cover.

Maintenance

Refrigerated air dryers require very little maintenance for satisfactory operation. Optimum performance can be expected if the following routine maintenance steps are taken.



WARNING!

- Before any service or maintenance work is performed on the refrigerated air dryer system, disconnect power supply and lock out power supply and depressurize system before performing maintenance or service work.
- Follow proper lock out/tag out procedures before performing service or maintenance work.
- Prior to performing any maintenance on the dryer, all personnel are strongly advised to familiarize themselves with the equipment by reading the entire contents of this operation manual. Follow all safety procedures prior to performing any maintenance activity on the dryer.

Daily

With the dryer on-line:

- Verify the operating pressure, temperature, and flow rate are correct and conform to those listed in the Design Parameters section. Adjust system if required.
- Always check refrigerant gauges to insure refrigeration system is working properly.
- Check condensate drain separator for proper condensate discharge. If no discharge is evident then depressurize the unit, dismantle and clean separator and/or drain line. Proper drain trap maintenance is the owner's responsibility. It is not covered by warranty.
- Make certain airflow is directed through dryer only. Observe by-pass valves proper positions.

Weekly

- Repeat all daily inspections and record data in the maintenance log.
- Clean the condenser coils of accumulated dust and dirt with a soft brush and/or with air pressure from a compressed air nozzle (maximum 100 psig).
- Check the gauge readings for optimum system operation.
- Check oil removal filter (coalescer) indicator (if applicable); if it is red, replace the filter.

Filter Element Replacement

1. Depressurize the air system to release the compressed air from the air dryer.
Notice: Shutting down the air compressor will not depressurize the air dryer unit.
Close air line valves before and after dryer and then depressurize unit.
Depressurize dryer by pushing the test button on the dryer system drain until there is no more pressure in the dryer system.
2. Remove the filter bowl by turning the bowl 1/4 turn counter clockwise, be sure the O-ring is in place on the top half of the oil filter housing and that the O-ring seats properly. Air leaks may occur if the O-ring is not secured (important).
3. The same procedure applies when removing the filter separator for changing the element (if applicable).

Troubleshooting



WARNING!

- Before any service or maintenance work is performed on the refrigerated air dryer system, disconnect power supply and lock out power supply and depressurize system.
- Follow proper lock out/tag out procedures before performing service or maintenance work.
- Prior to performing any maintenance on the dryer, all personnel are strongly advised to familiarize themselves with the equipment by reading the entire contents of this operation manual.
- Follow all safety procedures prior to performing any maintenance activity on the dryer.

If there is a problem with the refrigerated air dryer or contamination down stream is present, the problem may be identified from one or more of the following sources:

- Electrical
- Refrigeration
- Condensate removal (drains)
- Other

Electrical



WARNING!

- Follow proper lock out/tag out procedures before performing service or maintenance work.
 - Electrical installation or maintenance must be performed by a qualified electrician and comply with all applicable national and local codes.
- Make certain that the dryer is connected to proper power supply in accordance with electrical diagram provided.
 - Check electrical breaker, fuse, or disconnect to determine if there is electrical power to the unit.
 - A quick check should determine if the power switch is turned on and the unit is running.
 - After determining that power is supplied to the unit, go to the next step.

Refrigeration



WARNING!

Refrigerant handling must be performed by a qualified technician and all applicable national and local codes must be followed.

Notice: Always observe refrigerant pressure gauge(s) to determine if and how refrigeration circuit is operating.

Non-cycling refrigerated air dryers with R-134a refrigerant should have a suction gauge pressure reading of 28-40 psig and a discharge gauge pressure reading of 160-230 psig with the unit in the on position under full or partial load. If the refrigerant gauge(s) reads more or less than the above specified pressures, troubleshoot items on the following page.

1. High refrigerant readings generally indicate:

- Dirty condenser - Clean immediately!
- Dryer not turned on.
- Overloading - Airflow or conditions in excess of dryer capacity.
- High ambient temperature (> 100°F)
Provide adequate ventilation for proper cooling, or reduce ambient temperature.
- Condenser fan(s) not running - Call Technical Support.
- Refrigerant control too high - Contact technical support for assistance.

2. Low refrigerant readings generally indicate:

- Low ambient temperature - Temperatures below 40°F. Increase ambient temperatures or install head pressure control valve. Contact technical support for more information.
- Refrigerant control setting too low - Contact technical support for assistance.
- Loss of refrigerant - Call Technical Support or qualified refrigeration service.

Condensate Removal

The non-cycling refrigerated air dryer uses a refrigeration circuit to cool the compressed air which causes moisture to condense. The condensed moisture is separated from the dry air and purged through an automatic drain.

1. Condensate downstream of dryer:

- If the unit is equipped with automatic drain override switch, push manual override button to test drain flow.
- Ensure automatic electronic timer (if applicable) is functioning properly.
- Ensure moisture separator (and coalescer) drain lines are free from blockage.

- If the unit is equipped with y-strainer, disassemble and clean.
- If oil is downstream from the dryer:
 - Oil coalescer element is saturated.
 - Dryer not turned on during air usage.



WARNING!

Before any service or maintenance work is performed on the refrigerated air dryer system, disconnect power supply and lock out power supply and depressurize system before performing maintenance or service work.

Other

Sometimes a water or oil problem downstream from the dryer can be identified by an inadvertent action or inaction by the operator.

- Dryer not turned on before air usage.
- By-pass valves in wrong position.
- Air usage exceeding dryer capacity.
- Oil coalescer element dirty.
- Automatic drains not maintained.

Troubleshooting Table

Problem	Probable Cause	Remedy
Water downstream of dryer system or no discharge from separator/filter.	Failed or short circuited timer on drain.	Replace timer drain.
	Failed drain solenoid.	Replace timer drain.
	Bulk liquid entering the dryer from upstream.	Check drains on after cooler or air compressor.
	Inlet compressed air temperature to dryer exceeds dryer capacity air.	Check inlet air temperature and adjust as required to meet specifications.
	Inlet compressed air CFM flow rate exceeds dryer capacity.	Check in inlet air cfm flow rate and adjust as required to meet specifications.
Water downstream and dryer system not working properly.	Leak in the air to air side of the heat exchanger.	Replace heat exchanger.
	Refrigeration compressor stopped due to plugged or dirty condenser coil. (High Pressure)	Clean condensing coil and ensure adequate ventilation of unit.
	Refrigeration compressor cycles on/off and cannot maintain suction pressure.	Check condensing coil for dirt or debris that could prohibit adequate ventilation of the refrigerant circuit. If it is clean, check refrigerant pressure gauge(s) to determine if the unit is low on refrigerant.
	Low refrigerant.	Check for leak in refrigeration circuit, repair and recharge according to specifications.
	Low refrigerant, possible leak in air to refrigerant side of heat exchanger.	Repair or replace heat exchanger and recharge according to specifications.
	Refrigeration compressor is overheated.	Turn off dryer and wait 20 - 40 minutes, restart dryer. Refrigerant control settings may need adjustment, contact technical support.
	Refrigeration compressor has burned out or windings have gone to ground.	Replace compressor, check for leak in refrigeration circuit, repair and recharge according to specifications, contact technical support.

Troubleshooting Table, continued

Problem	Probable Cause	Remedy
Water downstream and dryer system not working properly or not working (Cont).	Refrigeration compressor cycles on/off and cannot maintain suction pressure, dryer undersized.	Check airflow (cfm) and dryer capacity. Reduce airflow through dryer or replace with a larger rated cfm dryer.
	Shorted fan motor winding.	Check fan motor with ohmmeter and refer to motor specifications for correct value. Check wiring schematic to ensure proper wiring of fan motor. Replace motor if required.
	Fan motor overload or unit short cycling.	Check circuitry against electrical schematic (wiring diagram). Check for high refrigerant pressure or for high ambient temperature.
	Defective overload protectors (fuses or breakers).	Check overload protectors and replace if necessary.
	Low voltage or 3-phase imbalance.	Check incoming power supply, voltage must be within 8-12% of rating on the serial plate label.
	Low water flow or pressure to water-cooled condenser.	Check water flow and/or pressure and adjust according to specifications. Contact technical support for assistance
	Defective fan control cycling switch.	Replace fan control cycling switch.
Low air pressure downstream or high pressure drop across the dryer system.	Optional pre-filter element dirty or plugged.	Replace filter element.
	Suction pressure below set point which causes freezing in the dryer heat exchanger.	Refrigeration controls may require adjustment, contact technical support for assistance.
	Suction pressure below set point which causes freezing in the dryer heat exchanger.*	Refrigeration circuit low on refrigerant, locate leak in refrigeration circuit, repair and recharge according to specifications.
*Notice: To confirm freeze-up, shut system off for 20 min and allow to thaw. Air pressure in line should come back to normal pressure.	Incorrect sizing or restriction in compressed air line piping.	Check compressed air piping for restrictions. Check piping size to verify if it has the capacity to handle the rated scfm at present working pressure of compressed air system.

Problem	Probable Cause	Remedy
<p>Low air pressure downstream due to continuous air flow through the moisture drain line.</p>	<p>Failed or short circuited timer on drain.</p>	<p>Replace timer drain.</p>
	<p>Failed drain solenoid.</p>	<p>Replace timer drain.</p>
	<p>Solenoid valve stuck open.</p>	<p>If power is off and the air stops leaking, replace the timer drain. If power is off and air continues leaking, clean the timer drain.</p>
<p>Noise or vibration coming from refrigerated air dryer system.</p>	<p>Shipping damage has caused compressor mounting to loosen.</p>	<p>Check all mounting bolts on compressor and tighten.</p>
	<p>Cabinet panels or support beams loosened during shipping.</p>	<p>Check all screws and bolts on dryer system and tighten.</p>
	<p>Loose mounting bolts, bent fan blade or worn bearings on condenser fan motor.</p>	<p>Tighten bolts, straighten or replace fan blade or replace motor.</p>
	<p>Noise coming from refrigeration compressor due to liquid refrigerant in compressor - caused by shipping or moving of dryer.</p>	<p>Let dryer system sit for six hours to allow refrigerant to settle out of compressor and to allow crankcase heater to warm compressor.</p>
<p>Timer drain stuck open.</p>	<p>Failed or dirty timer drain.</p>	<p>If power is off and the air stops leaking, replace the timer drain. If power is off and air continues leaking, clean the timer drain.</p>

Troubleshooting Table, continued

Problem	Probable Cause	Remedy
High Refrigeration Circuit Head Pressure (compressor is overloaded and gauge is reading out of recommended pressure range).	Refrigeration condenser coil fouled or dirty or air flow blocked.	Clean / blow off condensing coil of dirt or debris from the inside out. Clear area in front of condensing coil of any items blocking airflow to coil.
	Condenser fan motor not working properly.	Check fan motor for proper voltage and amp draw, repair or replace fan motor.
	Defective fan control switch.	Repair switch or replace.
	Ambient temperature too high at refrigeration dryer location.	Cool ambient temperature around location of refrigeration dryer down to a maximum of 100° F or relocate dryer to a different area with lower ambient temperature.
	Compressed air temperature entering the refrigeration dryer is too high.	Check compressed air inlet temperature to ensure it is within the operating parameters listed in the Design Parameter section. Check air compressor after cooler for proper operation.
Low Refrigeration Circuit Head Pressure (gauge is reading out of recommended pressure range).	Faulty heat exchanger, compressed air leaking into refrigeration circuit.	Repair or replace evaporator or heat exchanger and recharge with refrigerant.
	Ambient temperature too low at refrigeration dryer location.	Increase ambient temperature at refrigeration dryer location or relocate dryer. Head pressure control valve may be required for low ambient use. Contact technical support for assistance.
	Refrigeration dryer circuit low on refrigerant.	Refrigeration circuit low on refrigerant, locate leak in refrigeration circuit, repair and recharge according to specifications.
	Refrigeration compressor not working properly or faulty.	Check refrigeration compressor for proper voltage and amp draw, repair or replace refrigeration compressor.
	Compressed air temperature to refrigeration dryer too low.	The inlet compressed air temperature must be higher than 40° F. If compressed air temperature is lower than 40° F, turn refrigerated air dryer off. Air may pass through the dryer under this condition, once the compressed air temperature has increased to 44° F the dryer must be turned back on to avoid a high refrigerant pressure situation.

Problem	Probable Cause	Remedy
High refrigerant suction pressure, suction gauge reading out of range and water downstream of refrigeration dryer.	Refrigeration circuit hot gas bypass valve out of adjustment or defective.	Contact technical support for assistance.
	Refrigeration expansion valve or TXV adjustment fitting out of adjustment.	Contact technical support for assistance.
Low refrigerant suction pressure, suction gauge reading out of range and/ or refrigeration compressor covered with ice.	Refrigeration circuit hot gas bypass valve out of adjustment or defective.	Contact technical support for assistance.
	Refrigeration expansion valve or TXV adjustment fitting out of adjustment and is not feeding enough refrigerant to the evaporator.	Contact technical support for assistance.
	Excessive pressure drop on the high side of the refrigeration circuit.	Check for a plugged in line filter dryer or receiver on the refrigeration circuit that could be causing these restrictions.
Compressor oil downstream of refrigerated air dryer.	Check optional prefilter condensate drain for failure.	Dismantle prefilter drain and clean or replace.
	Failed or plugged prefilter element.	Check optional prefilter and replace element.
	Air compressor injecting excessive oil into the airstream.	Check air compressor for oil leak into the air stream, check air oil separator element for failure.

Appendix

Refrigerant Material Safety Data Sheet - R-134A (HP-20 – HP-500)



Prepared to U.S. OSHA, CMA, ANSI and Canadian WHMIS Standards

1. PRODUCT IDENTIFICATION

CHEMICAL NAME; CLASS: NON-FLAMMABLE GAS MIXTURE

Containing One of the Following Components in a Nitrogen or Air Balance Gas:
 Dichlorodifluoromethane, 0.0005-2.0%; Trichlorofluoromethane, 0.0005-2.0%;
 1,1,2-Trichloro-1,1,2-trifluoroethane, 0.0005-2.0%; Tetrafluoroethane, 0.0005-2.0%

SYNONYMS: Not Applicable
 CHEMICAL FAMILY NAME: Not Applicable
 FORMULA: Not Applicable
 Document Number: 50040

Note: The Material Safety Data Sheet is for this gas mixture supplied in cylinders with 33 cubic feet (935 liters) or less gas capacity (DOT -39 cylinders). This MSDS has been developed for various gas mixtures with the composition of components within the ranges listed in Section 2 (Composition and Information on Ingredients). Refer to the product label for information on the actual composition of the product.

PRODUCT USE:	Calibration of Monitoring and Research Equipment
SUPPLIER/MANUFACTURER'S NAME:	CALGAZ, LLC
ADDRESS:	821 Chesapeake Drive Cambridge, MD 21613
EMERGENCY PHONE:	CHEMTREC: 1-800-424-9300
BUSINESS PHONE:	1-410-228-6400
	General MSDS Information: 1-713/868-0440
	Fax on Demand: 1-800/231-1366

2. COMPOSITION and INFORMATION ON INGREDIENTS

CHEMICAL NAME	CAS #	mole %	EXPOSURE LIMITS IN AIR					
			ACGIH-TLV		OSHA-PEL		NIOSH IDLH ppm	OTHER ppm
			TWA ppm	STEL ppm	TWA ppm	STEL ppm		
Dichlorodifluoromethane (Freon 12)	75-71-8	0-2.0%	1000	NE	1000	NE	15,000	NIOSH REL: TWA = 1000 DFG MAKs: TWA = 1000 PEAK = 2•MAK 15 min., average value, 1 hr interval DFG MAK Pregnancy Risk Classification: C Carcinogenicity: TLV-A4
Trichlorofluoromethane (Freon 11)	75-69-4	0-2.0%	NE	1000 (ceiling)	1000	1000 (ceiling) (Vacated 1989 PEL)	2000	NIOSH REL: STEL = 1000 (ceiling) DFG MAKs: TWA = 1000 PEAK = 2•MAK, 15 min., average value, 1 hr interval DFG MAK Pregnancy Risk Classification: C Carcinogenicity: TLV-A4

CHEMICAL NAME	CAS #	mole %	EXPOSURE LIMITS IN AIR					
			ACGIH-TLV		OSHA-PEL		NIOSH IDLH ppm	OTHER ppm
			TWA ppm	STEL ppm	TWA ppm	STEL ppm		
1,1,2-Trichloro-1,1,2-trifluoroethane (Freon 113)	76-13-1	0-2.0%	1000	1250	1000	1250 (Vacated 1989 PEL)	2000	NIOSH RELs: TWA = 1000 STEL = 1250 DFG MAKs: TWA = 500 PEAK = 2•MAK 15 min., average value, 1 hr interval Carcinogenicity: TLV-A4
1,1,1,2-Tetrafluoroethane (HFC-134a)	811-97-2	0-2.0%	NE	NE	NE	NE	NE	DFG MAKs: TWA = 1000 PEAK = 8•MAK 15 min., average value, 1 hr interval DFG MAK Pregnancy Risk Classification: C
Nitrogen or Air	7727-37-9 132259-10-0	Balance	There are no specific exposure limits for Nitrogen. Nitrogen is a simple asphyxiant (SA). The composition of Air is as follows: 79% Nitrogen and 21% Oxygen. These components and their concentrations have been incorporated into this MSDS. There are no specific exposure limits for Oxygen. Oxygen levels should be maintained above 19.5%.					

NE = Not Established. See Section 16 for Definitions of Terms Used.
 NOTE (1): ALL WHMIS required information is included in appropriate sections based on the ANSI Z400.1-1998 format. This gas mixture has been classified in accordance with the hazard criteria of the CPR and the MSDS contains all the information required by the CPR.

3. HAZARD IDENTIFICATION

EMERGENCY OVERVIEW: This gas mixture is a colorless, odorless gas. Releases of this gas mixture for which Nitrogen is the balance gas may produce oxygen-deficient atmospheres (especially in confined spaces or other poorly-ventilated environments); individuals in such atmospheres may be asphyxiated. Components of this gas mixture (1,1,2-Trichloro-1,1,2-trifluoroethane, Tetrafluoromethane, Trichlorofluoromethane, and Dichlorodifluoromethane) may cause drowsiness and other central nervous system effects in high concentrations; however, due to their low concentration in this gas mixture, this is unlikely to occur. If components of this gas mixture (1,1,2-Trichloro-1,1,2-trifluoroethane, Tetrafluoromethane, Trichlorofluoromethane, and Dichlorodifluoromethane) are exposed to fire, they may decompose yielding toxic products (i.e. hydrogen fluoride, phosgene, hydrogen chloride, carbonyl fluoride).

SYMPTOMS OF OVER-EXPOSURE BY ROUTE OF EXPOSURE: The most significant route of over-exposure for this gas mixture is by inhalation.

INHALATION: Due to the small size of an individual cylinder of this gas mixture, no unusual health effects from over-exposure to the product are anticipated under routine circumstances of use. The chief health hazard associated with this gas mixture for which Nitrogen is the balance gas and is released in a small, poorly-ventilated area (i.e. an enclosed or confined space) is the development of an oxygen-deficient environment. Individuals breathing such an atmosphere may experience symptoms which include headaches, ringing in ears, dizziness, drowsiness, unconsciousness, nausea, vomiting, and depression of all the senses. Under some circumstances of over-exposure, death may occur. The effects associated with various levels of oxygen are as follows:

CONCENTRATION OF OXYGEN:

12-16% Oxygen:

10-14% Oxygen:

6-10% Oxygen:

Below 6%:

OBSERVED EFFECT

Breathing and pulse rate increased, muscular coordination slightly disturbed. Emotional upset, abnormal fatigue, disturbed respiration.

Nausea, vomiting, collapse, or loss of consciousness.

Convulsive movements, possible respiratory collapse, and death.

HEALTH EFFECTS OR RISKS FROM EXPOSURE: An Explanation in Lay Terms.

Over-exposure to this gas mixture may cause the following health effects:

ACUTE: Due to the small size of the individual cylinder of this gas mixture, no unusual health effects from exposure to the product are anticipated under routine circumstances of use. The most significant hazard associated with this gas mixture when it contains less than 19.5% oxygen is the potential for exposure to oxygen-deficient atmospheres. Symptoms of oxygen deficiency include respiratory difficulty, ringing in ears, headaches, shortness of breath, wheezing, headache, dizziness, indigestion, nausea, unconsciousness, and death. The skin of a victim of over-exposure may have a blue color.

CHRONIC: Chronic exposure to oxygen-deficient atmospheres (below 18% oxygen in air) may effect the heart and nervous system.

TARGET ORGANS: ACUTE: Respiratory system, eyes. CHRONIC: Heart, cardiovascular system, central nervous system, reproductive system.

HAZARDOUS MATERIAL IDENTIFICATION SYSTEM		
HEALTH HAZARD (BLUE)		1
FLAMMABILITY HAZARD (RED)		0
PHYSICAL HAZARD (YELLOW)		0
PROTECTIVE EQUIPMENT		
EYES	RESPIRATORY	HANDS BODY
See Section 8		
For Routine Industrial Use and Handling Applications		

4. FIRST-AID MEASURES

RESCUERS SHOULD NOT ATTEMPT TO RETRIEVE VICTIMS OF EXPOSURE TO THIS GAS MIXTURE WITHOUT ADEQUATE PERSONAL PROTECTIVE EQUIPMENT. If necessary, Self-Contained Breathing Apparatus must be worn.

No unusual health effects are anticipated after exposure to this gas mixture, due to the small cylinder size. If any adverse symptom develops after over-exposure to this gas mixture, remove victim(s) to fresh air as quickly as possible. Only trained personnel should administer supplemental oxygen and/or cardio-pulmonary resuscitation if necessary. Victim(s) who experience any adverse effect after over-exposure to this gas mixture must be taken for medical attention. Rescuers should be taken for medical attention if necessary. Take a copy of the label and the MSDS to physician or other health professional with victim(s).

MEDICAL CONDITIONS AGGRAVATED BY EXPOSURE: Acute or chronic respiratory conditions may be aggravated by over-exposure to the components of this gas mixture.

RECOMMENDATIONS TO PHYSICIANS: Administer oxygen, if necessary; treat symptoms; eliminate exposure. Note: Epinephrine increases the toxicity of Chlorodifluoromethane on the heart.

5. FIRE-FIGHTING MEASURES

FLASH POINT: Not applicable.

AUTOIGNITION TEMPERATURE: Not applicable.

FLAMMABLE LIMITS (in air by volume, %):

Lower (LEL): Not applicable.

Upper (UEL): Not applicable.

FIRE EXTINGUISHING MATERIALS: Non-flammable gas mixture. Use extinguishing media appropriate for surrounding fire.

UNUSUAL FIRE AND EXPLOSION HAZARDS: This gas mixture is not flammable; however, containers, when involved in fire, may rupture or burst in the heat of the fire. Additionally, mixtures of this gas for which Air is the balance gas, can support combustion.

Explosion Sensitivity to Mechanical Impact: Not sensitive.

Explosion Sensitivity to Static Discharge: Not sensitive.

SPECIAL FIRE-FIGHTING PROCEDURES: Structural firefighters must wear Self-Contained Breathing Apparatus and full protective equipment. If water is not available for cooling or protection of cylinder exposures, evacuate the area.

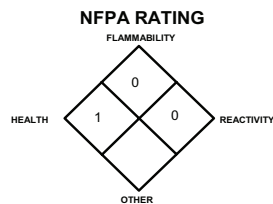

6. ACCIDENTAL RELEASE MEASURES

LEAK RESPONSE: Due to the small size and content of the cylinder, an accidental release of this gas mixture presents significantly less risk of an oxygen-deficient environment and other safety hazards than a similar release from a larger cylinder. However, as with any chemical release, extreme caution must be used during emergency response procedures. In the event of a release in which the atmosphere is unknown, and in which other chemicals are potentially involved, evacuate immediate area. Such releases should be responded to by trained personnel using pre-planned procedures. Proper protective equipment should be used. In case of a leak, clear the affected area, protect people, and respond with trained personnel. Allow the gas mixture to dissipate. If necessary, monitor the surrounding area (and the original area of the release) for oxygen. Oxygen levels must be above 19.5% before non-emergency personnel are allowed to re-enter area. If leaking incidentally from the cylinder, contact your supplier.

7. HANDLING and USE

WORK PRACTICES AND HYGIENE PRACTICES: Be aware of any signs of dizziness or fatigue, especially if work is done in a poorly-ventilated area; exposures to fatal concentrations of this gas mixture could occur without any significant warning symptoms, due to oxygen deficiency. Do not attempt to repair, adjust, or in any other way modify cylinders containing this gas mixture. If there is a malfunction or another type of operational problem, contact nearest distributor immediately.

STORAGE AND HANDLING PRACTICES: Cylinders should be firmly secured to prevent falling or being knocked-over. Cylinders must be protected from the environment, and preferably kept at room temperature (approximately 21°C [70°F]). Cylinders should be stored in dry, well-ventilated areas, away from sources of heat, ignition, and direct sunlight. Protect cylinders against physical damage.

Full and empty cylinders should be segregated. Use a first-in, first-out inventory system to prevent full containers from being stored for long periods of time. These cylinders are not refillable. **WARNING! Do not refill DOT 39 cylinders. To do so may cause personal injury or property damage.**

SPECIAL PRECAUTIONS FOR HANDLING GAS CYLINDERS: WARNING! Compressed gases can present significant safety hazards. During cylinder use, use equipment designed for these specific cylinders. Ensure all lines and equipment are rated for proper service pressure.

PROTECTIVE PRACTICES DURING MAINTENANCE OF CONTAMINATED EQUIPMENT: Follow practices indicated in Section 6 (Accidental Release Measures). Make certain that application equipment is locked and tagged-out safely. Always use product in areas where adequate ventilation is provided.

R134-A Refrigerant Material Safety Data Sheet, continued

8. EXPOSURE CONTROLS - PERSONAL PROTECTION

VENTILATION AND ENGINEERING CONTROLS: No special ventilation systems or engineering controls are needed under normal circumstances of use. As with all chemicals, use this gas mixture in well-ventilated areas. If this gas mixture is used in a poorly-ventilated area, install automatic monitoring equipment to detect the levels of Phosphine and Oxygen.

RESPIRATORY PROTECTION: No special respiratory protection is required under normal circumstances of use. Maintain Phosphine levels below 50% of the TLV (TLV = 0.3 ppm) and oxygen levels above 19.5% in the workplace. Use supplied air respiratory protection when Phosphine levels exceed 50% of the TLV (TLV = 0.3 ppm), oxygen levels are below 19.5%, or during emergency response to a release of this gas mixture. During an emergency situation, before entering the area, check the concentration of Phosphine and Oxygen. If respiratory protection is required, follow the requirements of the Federal OSHA Respiratory Protection Standard (29 CFR 1910.134), or equivalent State standards.

EYE PROTECTION: Safety glasses. If necessary, refer to U.S. OSHA 29 CFR 1910.133 or appropriate Canadian Standards.

HAND PROTECTION: Wear leather gloves when handling cylinders. Chemically resistant gloves should be worn when using this gas mixture. If necessary, refer to U.S. OSHA 29 CFR 1910.138 or appropriate Standards of Canada.

BODY PROTECTION: No special protection is needed under normal circumstances of use. If a hazard of injury to the feet exists due to falling objects, rolling objects, where objects may pierce the soles of the feet or where employee's feet may be exposed to electrical hazards, use foot protection, as described in U.S. OSHA 29 CFR 1910.136.

9. PHYSICAL and CHEMICAL PROPERTIES

The following information is for Nitrogen, the main component of this gas mixture.

GAS DENSITY @ 32°F (0°C) and 1 atm: .072 lbs/ft³ (1.153 kg/m³)

FREEZING/MELTING POINT @ 10 psig: -345.8°F (-210°C)

SPECIFIC GRAVITY (air = 1) @ 70°F (21.1°C): 0.906

SOLUBILITY IN WATER vol/vol @ 32°F (0°C) and 1 atm: 0.023

EVAPORATION RATE (nBuAc = 1): Not applicable.

VAPOR PRESSURE @ 70°F (21.1°C) (psig): Not applicable.

COEFFICIENT WATER/OIL DISTRIBUTION: Not applicable.

BOILING POINT: -320.4°F (-195.8°C)

pH: Not applicable.

MOLECULAR WEIGHT: 28.01

EXPANSION RATIO: Not applicable.

SPECIFIC VOLUME (ft³/lb): 13.8

The following information is for Air, a balance gas:

The following information is for Air, a balance gas:

BOILING POINT: -317.8°F (-194.3°C)

SOLUBILITY IN WATER Vol/Vol @ 0°C (32°F): 0.0292

SPECIFIC GRAVITY (air = 1) @ 70°F (21.1°C): 1

EVAPORATION RATE (nBuAc = 1): Not applicable.

ODOR THRESHOLD: Not applicable.

VAPOR PRESSURE @ 21.1°C; 70°F (psig): Not applicable.

FREEZING/MELTING POINT @ 10 psig: -216.2°C (-357.2°F)

MOLECULAR WEIGHT: 28.975

pH: Not applicable.

EXPANSION RATIO: Not applicable.

SPECIFIC VOLUME (ft³/lb): Not applicable for Air; 13.8 (for Nitrogen)

COEFFICIENT WATER/OIL DISTRIBUTION: Not applicable.

The following information is for the gas mixture:

APPEARANCE AND COLOR: This gas mixture is a colorless, odorless gas.

HOW TO DETECT THIS SUBSTANCE (warning properties): In terms of leak detection, fittings and joints can be painted with a soap solution to detect leaks, which will be indicated by a bubble formation.

10. STABILITY and REACTIVITY

STABILITY: Normally stable in gaseous state.

DECOMPOSITION PRODUCTS: Due to components of this gas mixture (1,1,2-Trichloro-1,1,2-trifluoroethane, Tetrafluoromethane, Trichlorofluoromethane, and Dichlorodifluoromethane), if exposed to fire, this gas mixture may decompose yielding toxic products (i.e. hydrogen fluoride, phosgene, hydrogen chloride, carbonyl fluoride). The other components of this gas mixture do not decompose, per se, but can react with other compounds in the heat of a fire.

MATERIALS WITH WHICH SUBSTANCE IS INCOMPATIBLE: Titanium will burn in Nitrogen (a main component of this gas mixture). Lithium reacts slowly with Nitrogen at ambient temperatures. Components of this gas mixture (1,1,2-Trichloro-1,1,2-trifluoroethane, Tetrafluoromethane, Trichlorofluoromethane, and Dichlorodifluoromethane) are incompatible with sodium, potassium, calcium, zinc, and magnesium, powdered aluminum, and alloys of these metals.

HAZARDOUS POLYMERIZATION: Will not occur.

CONDITIONS TO AVOID: Contact with incompatible materials. Cylinders exposed to high temperatures or direct flame can rupture or burst.

11. TOXICOLOGICAL INFORMATION

TOXICITY DATA: The following toxicology data are available for the components of this gas mixture:

DICHLORODIFLUOROMETHANE:

LC (Inhalation-rat) > 80 pph/4 hours
LC₅₀ (Inhalation-mouse) 3348 gm/m³/3 hours: Behavioral: sleep, tremor, excitement

LC₅₀ (Inhalation-rabbit) 80 pph/30 minutes
LC₅₀ (Inhalation-guinea pig) 80 pph/30 minutes

TCLo (Inhalation-Human) 200000 ppm/30 minutes: conjunctive, fibrosing

TCLo (Inhalation-rat) 4136 mg/m³/8 hours/6 weeks-intermittent: chronic pulmonary edema; Related to Chronic Data: death

TCLo (Inhalation-rat) 3997 mg/m³/90 days-continuous: Lungs, Thorax, or Respiration: chronic pulmonary edema; death

TCLo (Inhalation-monkey) 3997 mg/m³/90 days-continuous: Lungs, Thorax, or Respiration: chronic pulmonary edema

TCLo (Inhalation-rabbit) 3997 mg/m³/90 days-continuous: Lungs, Thorax, or Respiration: chronic pulmonary edema

TCLo (Inhalation-guinea pig) 3997 mg/m³/90 days-continuous: Lungs, Thorax, or Respiration: chronic pulmonary edema; death

LD (Oral-rat) > 5600 µg/kg

TDLo (Oral-rat) 2548 mg/kg/26 weeks-intermittent: Behavioral: alteration of classical conditioning; Blood: changes

in erythrocyte (RBC) count; Biochemical: Enzyme inhibition, induction, or change in blood or tissue levels: true cholinesterase

1,1,1,2-TETRAFLUOROETHANE:

LC₅₀ (Inhalation-Rat) 1500 gm/m³/4 hours

LC₅₀ (Inhalation-Mouse) 1700 gm/m³/2 hours

LC (Inhalation-Dog) > 32 pph/1 hour

TCLo (Inhalation-Rat) 50,000 ppm/6 hours/2 years-intermittent: Tumorigenic:

neoplastic by RTECS criteria; Endocrine: tumors

TCLo (Inhalation-Rat) 30 pph/6 hours: female 6-15 day(s) after conception:

Reproductive: Maternal Effects: other effects; Effects on Embryo or Fetus: fetotoxicity (except death, e.g., stunted fetus)

TRICHLOROFLUOROMETHANE:

TCLo (Inhalation-Human) 50,000 ppm/30 minutes: Sense Organs and Special

Senses (Eye):conjunctive irritation; Lungs, Thorax, or Respiration: fibrosing

alveolitis; Liver: other changes

LD (Oral-Rat) > 352 mg/kg

LD₅₀ (Intrapitoneal-Mouse) 1743 mg/kg: Behavioral: convulsions or effect on seizure threshold

LC₅₀ (Inhalation-Rat) 13 pph/15 minutes:

Behavioral: tremor, convulsions or effect on seizure threshold; Lungs, Thorax, or Respiration: respiratory depression

LC₅₀ (Inhalation-Mouse) 10 pph/30 minutes

LC₅₀ (Inhalation-Rabbit) 25 pph/30

LC₅₀ (Inhalation-Guinea Pig) 25 pph/30 minutes

TCLo (Inhalation-Rat) 12,000 ppm/4 hours/days-intermittent: Brain and Coverings: other degenerative changes;

Lungs, Thorax, or Respiration: chronic pulmonary edema

1,1,2-TRICHLORO-1,1,2-

TRIFLUOROETHANE:

TCLo (Inhalation-Human) 4300 mg/m³/5 Days-intermittent: Brain and Coverings: recordings from specific areas of CNS

TCLo (Inhalation-Human) 178 mg/m³/10 years-intermittent: Behavioral: headache

Open Irritation Test (Skin-Rabbit) 500 mg: Mild

Standard Draize Test (Skin-Rabbit) 500 mg/24 hours: Mild

LD₅₀ (Oral-Rat) 43 gm/kg: Behavioral: somnolence (general depressed activity); Gastrointestinal: other

changes; Skin and Appendages: hair

LD₅₀ (Intravenous-Mouse) 9 gm/kg: Autonomic Nervous System: other (direct) para-sympathomimetic;

Behavioral: altered sleep time (including change in righting reflex); Skin and Appendages: dermatitis, other (after systemic exposure)

LD₅₀ (Unreported-Mouse) 40 gm/kg

LDLo (Oral-Rabbit) 17 gm/kg

LC₅₀ (Inhalation-Rat) 38,500 ppm/4 hours: Behavioral: general anesthetic, excitement, ataxia

11. TOXICOLOGICAL INFORMATION**1,1,2-TRICHLORO-1,1,2-**

TRIFLUOROETHANE (continued):
 LC₅₀ (Inhalation-Mouse) 260 gm/m³/2 hours:
 Behavioral: somnolence (general depressed activity), ataxia; Lungs, Thorax, or Respiration: cyanosis
 LC₅₀ (Inhalation-Rabbit) 59,500 ppm/2 hours: Sense Organs and Special Senses (Eye): effect, not otherwise specified; Behavioral: excitement; Lungs, Thorax, or Respiration: respiratory stimulation
 LC₅₀ (Inhalation-Guinea Pig) >12 pph/2 hours
 LD (Skin-Rabbit) > 11 gm/kg
 LDLo (Oral-Guinea Pig) > 10 gm/kg
 TCLo (Inhalation-Rat) 20 pph/6 hours/2 years-intermittent: Kidney, Ureter,

Bladder: other changes in urine composition; Nutritional and Gross Metabolic: weight loss or decreased weight gain
 TCLo (Inhalation-Rat) 2000 ppm/6 hours/2 weeks-intermittent: Liver: other changes; Biochemical: Enzyme inhibition, induction, or change in blood or tissue levels: hepatic microsomal mixed oxidase (dealkylation, hydroxylation, etc.); Biochemical: Enzyme inhibition, induction, or change in blood or tissue levels: other transferases
 TCLo (Inhalation-Guinea Pig) 70000 mg/m³/4 hours/16 weeks-intermittent: Brain and Coverings: recordings from specific areas of CNS; Lungs, Thorax, or Respiration: other changes;

Biochemical: Enzyme inhibition, induction, or change in blood or tissue levels: phosphatases
 TCLo (Inhalation-Rabbit) 20 ppm: female 8-16 (day(s)) after conception: Reproductive: Maternal Effects: other effects; Effects on Newborn: physical effects; TDLo (Oral-Rabbit) 5 gm/kg: female 8 day(s) after conception: Reproductive: Maternal Effects: other effects; Fertility: abortion; Effects on Embryo or Fetus: fetal death
NITROGEN:
 There are no specific toxicology data for Nitrogen. Nitrogen is a simple asphyxiant, which acts to displace oxygen in the environment.

SUSPECTED CANCER AGENT: The components of this gas mixture are listed by agencies tracking the carcinogenic potential of chemical compounds, as follows:

DICHLORODIFLUOROMETHANE: ACGIH TLV-A4 (Not Classifiable as to Carcinogenicity in Humans)

TRICHLORODIFLUOROMETHANE: ACGIH TLV-A4 (Not Classifiable as to Carcinogenicity in Humans)

1,1,2-TRICHLORO-1,1,2-TRIFLUOROETHANE: ACGIH TLV-A4 (Not Classifiable as to Carcinogenicity in Humans)

The remaining components of this gas mixture are not found on the following lists: FEDERAL OSHA Z LIST, NTP, CAL/OSHA, and IARC; therefore, they are not considered to be, nor suspected to be, cancer-causing agents by these agencies. Nitrous Oxide is listed as ACGIH-A4 (Not Classifiable as a Human Carcinogen).

IRRITANCY OF PRODUCT: Contact with rapidly expanding gases can be irritating to exposed skin and eyes.

SENSITIZATION TO THE PRODUCT: This gas mixture is not known to cause sensitization in humans.

REPRODUCTIVE TOXICITY INFORMATION: Listed below is information concerning the effects of this gas mixture and its components on the human reproductive system.

Mutagenicity: No mutagenicity effects have been described for the components of this gas mixture.

Embryotoxicity: No embryotoxic effects have been described for the components of this gas mixture.

Teratogenicity: No teratogenicity effects have been described for the components of this gas mixture.

Reproductive Toxicity: No reproductive toxicity effects have been described for the components of this gas mixture.

A **mutagen** is a chemical which causes permanent changes to genetic material (DNA) such that the changes will propagate through generation lines. An **embryotoxin** is a chemical which causes damage to a developing embryo (i.e. within the first eight weeks of pregnancy in humans), but the damage does not propagate across generational lines. A **teratogen** is a chemical which causes damage to a developing fetus, but the damage does not propagate across generational lines. A **reproductive toxin** is any substance which interferes in any way with the reproductive process.

BIOLOGICAL EXPOSURE INDICES (BEIs): Currently, Biological Exposure Indices (BEIs) have not been determined for the components of this gas mixture.

12. ECOLOGICAL INFORMATION

ENVIRONMENTAL STABILITY: The gas will be dissipated rapidly in well-ventilated areas. 1,1,2-Trichloro-1,1,2-trifluoroethane, Trichlorofluoromethane, and Dichlorodifluoromethane are chlorofluorocarbon (CFC) compounds. Chlorofluorocarbon compounds have been implicated in the possible depletion of the stratospheric ozone, via a series of complex chemical reactions which occur in the upper atmosphere. Atmospheric ozone is essential in protecting plants and animals from potentially harmful ultraviolet-light exposures. All work practice must be directed at eliminating environmental contamination. The following environmental data are applicable to the components of this gas mixture.

DICHLORODIFLUOROMETHANE: Log Kow = 2.16; Water Solubility = 0.28 g/L 27-25°C.

OXYGEN: Water Solubility = 1 volume Oxygen/32 volumes water at 20°C. Log K_{ow} = -0.65

NITROGEN: Water Solubility = 2.4 volumes Nitrogen/100 volumes water at 0°C. 1.6 volumes Nitrogen/100 volumes water at 20°C.

EFFECT OF MATERIAL ON PLANTS or ANIMALS: No evidence is currently available on the effects of this gas mixture on plant and animal life.
EFFECT OF CHEMICAL ON AQUATIC LIFE: No evidence is currently available on this gas mixture's effects on aquatic life. The following aquatic toxicity data are available for the components of this gas mixture.

1,1,1,2-TETRAFLUOROETHANE:

EC₅₀ (*Daphnia magna*) 48 hours = 980 mg/L

LC₅₀ (*Daphnia magna*) 48 hours = 450 mg/L

13. DISPOSAL CONSIDERATIONS

PREPARING WASTES FOR DISPOSAL PREPARING WASTES FOR DISPOSAL: Waste disposal must be in accordance with appropriate Federal, State, and local regulations. Cylinders with undesired residual product may be safely vented outdoors with the proper regulator. For further information, refer to Section 16 (Other Information).

14. TRANSPORTATION INFORMATION

THIS GAS MIXTURE IS HAZARDOUS AS DEFINED BY 49 CFR 172.101 BY THE U.S. DEPARTMENT OF TRANSPORTATION.

THIS GAS MIXTURE IS HAZARDOUS AS DEFINED BY 49 CFR 172.101 BY THE U.S. DEPARTMENT OF TRANSPORTATION.

PROPER SHIPPING NAME: Compressed gases, n.o.s. ("Oxygen, Nitrogen") or the gas component with the next highest concentration next to Nitrogen.

HAZARD CLASS NUMBER and DESCRIPTION: 2.2 (Non-Flammable Gas)

UN IDENTIFICATION NUMBER: UN 1956

PACKING GROUP: Not applicable.

DOT LABEL(S) REQUIRED: Non-Flammable Gas

NORTH AMERICAN EMERGENCY RESPONSE GUIDEBOOK NUMBER (2000): 126

MARINE POLLUTANT: The components of this gas mixture are not classified by the DOT as Marine Pollutants (as defined by 49 CFR 172.101, Appendix B).

SPECIAL SHIPPING INFORMATION: Cylinders should be transported in a secure position, in a well-ventilated vehicle. The transportation of compressed gas cylinders in automobiles or in closed-body vehicles can present serious safety hazards. If transporting these cylinders in vehicles, ensure these cylinders are not exposed to extremely high temperatures (as may occur in an enclosed vehicle on a hot day). Additionally, the vehicle should be well-ventilated during transportation.

Note: DOT 39 Cylinders ship in a strong outer carton (overpack). Pertinent shipping information goes on the outside of the overpack. DOT 39 Cylinders do not have transportation information on the cylinder itself.

TRANSPORT CANADA TRANSPORTATION OF DANGEROUS GOODS REGULATIONS: This gas is considered as Dangerous Goods, per regulations of Transport Canada.

PROPER SHIPPING NAME: Compressed gases, n.o.s. ("Oxygen, Nitrogen") or the gas component with the next highest concentration next to Nitrogen.

HAZARD CLASS NUMBER and DESCRIPTION: 2.2 (Non-Flammable Gas)

UN IDENTIFICATION NUMBER: UN 1046

PACKING GROUP: Not Applicable

HAZARD LABEL: Class 2.2 (Non-Flammable Gas)

SPECIAL PROVISIONS: None

EXPLOSIVE LIMIT AND LIMITED QUANTITY INDEX: 0.12

ERAP INDEX: None

PASSENGER CARRYING SHIP INDEX: None

PASSENGER CARRYING ROAD VEHICLE OR PASSENGER CARRYING RAILWAY VEHICLE INDEX: 75

NORTH AMERICAN EMERGENCY RESPONSE GUIDEBOOK NUMBER (2000): 121 **NOTE:** Shipment of compressed gas cylinders in a Public Passenger Road Vehicle is a violation of Canadian law (Transport Canada Transportation of Dangerous Goods Act, 1992).

R134-A Refrigerant Material Safety Data Sheet, continued

15. REGULATORY INFORMATION

ADDITIONAL U.S. REGULATIONS:

U.S. SARA REPORTING REQUIREMENTS: This gas mixture is subject to the reporting requirements of Sections 302, 304, and 313 of Title III of the Superfund Amendments and Reauthorization Act, as follows:

COMPOUND	SARA 302 (40 CFR 355, Appendix A)	SARA 304 (40 CFR Table 302.4)	SARA 313 (40 CFR 372.65)
Dichlorodifluoromethane	NO	NO	YES
Trichlorofluoromethane	NO	NO	YES
1,1,2-Trichloro-1,1,2-trifluoroethane	NO	NO	YES

U.S. SARA THRESHOLD PLANNING QUANTITY: There are no specific Threshold Planning Quantities for the components of this gas mixture. The default Federal MSDS submission and inventory requirement filing threshold of 10,000 lb (4,540 kg) may apply, per 40 CFR 370.20.

U.S. TSCA INVENTORY STATUS: The components of this gas mixture are listed on the TSCA Inventory.

U.S. CERCLA REPORTABLE QUANTITY (RQ): Dichlorodifluoromethane = 5000 lbs (2270 kg); Trichlorofluoromethane = 5000 lb (2270 kg). The 1,1,2-Trichloro-1,1,2-Trifluoroethane component is a CERCLA Hazardous Substance which has no specific RQ assigned.

U.S. OTHER U.S. FEDERAL REGULATIONS:

- 1,1,2-Trichloro-1,1,2-trifluoroethane, Trichlorofluoromethane, and Dichlorodifluoromethane are subject to the requirements of CFR 29 1910.1000. These gases are listed on Table Z.1.
- No component of this gas mixture is subject to the reporting requirements of Section 112(r) of the Clean Air Act.
- 1,1,2-Trichloro-1,1,2-trifluoroethane, Trichlorofluoromethane, and Dichlorodifluoromethane are listed as Class I ozone-depleting chemicals. This gas mixture is required to bear the following label:
Warning: Contains Name of Chlorofluorocarbon, a substance which harms public health and environment by destroying ozone in the upper atmosphere.
- Chlorodifluoromethane is subject to the reporting requirements under Title VI of the Clean Air Act Amendments of 1990: "Stratospheric Ozone Protection".
- The components of this gas mixture are not listed in Appendix A as a highly hazardous chemical, per 29 CFR 1910.119: Process Safety Management of Highly Hazardous Chemicals.
- Nitrogen, Oxygen, Tetrafluoromethane, 1,1,2-Trichloro-1,1,2-trifluoroethane, Trichlorofluoromethane, and Dichlorodifluoromethane are not listed as Regulated Substances, per 40 CFR, Part 68, of the Risk Management for Chemical Releases.

U.S. STATE REGULATORY INFORMATION: The components of this gas mixture are covered under the following specific State regulations:

Alaska - Designated Toxic and Hazardous Substances: Trichlorofluoromethane, Dichlorodifluoro-methane, 1,1,2-Trichloro-1,1,2-trifluoroethane.

California - Permissible Exposure Limits for Chemical Contaminants: Trichlorofluoromethane, Dichlorodifluoro-methane, Nitrogen, 1,1,2-Trichloro-1,1,2-trifluoroethane.

Florida - Substance List: Oxygen, Trichlorofluoromethane, Dichlorodi-fluoromethane, 1,1,2-Trichloro-1,1,2-trifluoro-ethane.

Illinois - Toxic Substance List: Trichlorofluoromethane, Dichlorodi-fluoromethane, 1,1,2-Trichloro-1,1,2-trifluoro-ethane.

Kansas - Section 302/313 List: No.

Massachusetts - Substance List: Trichlorofluoromethane, Dichlorodi-fluoromethane, Oxygen, 1,1,2-Trichloro-1,1,2-trifluoroethane.

Minnesota - List of Hazardous Substances: Trichlorofluoromethane, Dichlorodi-fluoromethane, 1,1,2-Trichloro-1,1,2-trifluoroethane.

Missouri - Employer Information/Toxic Substance List: Trichlorofluoromethane, Dichlorodi-fluoromethane, 1,1,2-Trichloro-1,1,2-trifluoroethane.

New Jersey - Right to Know Hazardous Substance List: Trichlorofluoromethane, Dichlorodi-fluoromethane, Oxygen, Nitrogen, 1,1,2-Trichloro-1,1,2-trifluoroethane.

North Dakota - List of Hazardous Chemicals, Reportable Quantities: Trichlorofluoromethane, Dichlorodi-fluoro-methane.

Pennsylvania - Hazardous Substance List: Trichlorofluoromethane, Dichlorodi-fluoromethane, Oxygen, Nitrogen, 1,1,2-Trichloro-1,1,2-trifluoro-ethane.

Rhode Island - Hazardous Substance List: Trichlorofluoromethane, Dichlorodi-fluoromethane, Oxygen.

Texas - Hazardous Substance List: Trichlorofluoromethane, Dichlorodi-fluoromethane, 1,1,2-Trichloro-1,1,2-trifluoroethane.

West Virginia - Hazardous Substance List: Trichlorofluoromethane, Dichlorodi-fluoro-methane, 1,1,2-Trichloro-1,1,2-trifluoro-ethane.

Wisconsin - Toxic and Hazardous Substances: Trichlorofluoromethane, Dichlorodi-fluoromethane, 1,1,2-Trichloro-1,1,2-trifluoroethane.

CALIFORNIA SAFE DRINKING WATER AND TOXIC ENFORCEMENT ACT (PROPOSITION 65): No component of this gas mixture is on the California Proposition 65 lists.

ADDITIONAL CANADIAN REGULATIONS:

CANADIAN DSL/NDL INVENTORY STATUS: The components of this gas mixture are listed on the DSL Inventory.

CANADIAN ENVIRONMENTAL PROTECTION ACT (CEPA) PRIORITIES SUBSTANCES LISTS: The components of this gas mixture are not on the CEPA Priorities Substances Lists.

CANADIAN WHMIS CLASSIFICATION: This gas mixture is categorized as a Controlled Product, Hazard Class A, as per the Controlled Product Regulations.

16. OTHER INFORMATION

INFORMATION ABOUT DOT-39 NRC (Non-Refillable Cylinder) PRODUCTS

DOT 39 cylinders ship as hazardous materials when full. Once the cylinders are relieved of pressure (empty) they are not considered hazardous material or waste. Residual gas in this type of cylinder is not an issue because toxic gas mixtures are prohibited. Calibration gas mixtures typically packaged in these cylinders are Nonflammable n.o.s., UN 1956. A small percentage of calibration gases packaged in DOT 39 cylinders are flammable or oxidizing gas mixtures.

For disposal of used DOT-39 cylinders, it is acceptable to place them in a landfill if local laws permit. Their disposal is no different than that employed with other DOT containers such as spray paint cans, household aerosols, or disposable cylinders of propane (for camping, torch etc.). When feasible, we recommended recycling for scrap metal content. CALGAZ, LLC will do this for any customer that wishes to return cylinders to us prepaid. All that is required is a phone call to make arrangements so we may anticipate arrival. Scrapping cylinders involves some preparation before the metal dealer may accept them. We perform this operation as a service to valued customers who want to participate.

MIXTURES: When two or more gases or liquefied gases are mixed, their hazardous properties may combine to create additional, unexpected hazards. Obtain and evaluate the safety information for each component before you produce the mixture. Consult an Industrial Hygienist or other trained person when you make your safety evaluation of the end product. Remember, gases and liquids have properties which can cause serious injury or death.

Further information about the handling of compressed gases can be found in the following pamphlets published by: Compressed Gas Association Inc. (CGA), 1725 Jefferson Davis Highway, Suite 1004, Arlington, VA 22202-4102. Telephone: (703) 412-0900.

P-1 "Safe Handling of Compressed Gases in Containers"
AV-1 "Safe Handling and Storage of Compressed Gases"
"Handbook of Compressed Gases"

PREPARED BY:

CHEMICAL SAFETY ASSOCIATES, Inc.
PO Box 3519, La Mesa, CA 91944-3519
619/565-0302

Fax on Demand: 1-800/231-1366



This Material Safety Data Sheet is offered pursuant to OSHA's Hazard Communication Standard, 29 CFR, 1910.1200. Other government regulations must be reviewed for applicability to this gas mixture. To the best of CALGAZ, LLC's knowledge, the information contained herein is reliable and accurate as of this date; however, accuracy, suitability or completeness are not guaranteed and no warranties of any type, either express or implied, are provided. The information contained herein relates only to this specific product. If this gas mixture is combined with other materials, all component properties must be considered. Data may be changed from time to time. Be sure to consult the latest edition.

Appendix

Refrigerant Material Safety Data Sheet - R-404A (HP-700)

NATIONAL REFRIGERANTS™

Material Safety Data Sheet

R-404A

1. CHEMICAL PRODUCT AND COMPANY IDENTIFICATION

PRODUCT NAME: R-404A
DISTRIBUTOR: National Refrigerants, Inc.
 661 Kenyon Avenue
 Bridgeton, New Jersey 08302

FOR MORE INFORMATION CALL:
 (Monday-Friday, 8:00am-5:00pm)
 1-800-262-0012

IN CASE OF EMERGENCY CALL:
 CHEMTREC: 1-800-424-9300

2. COMPOSITION / INFORMATION ON INGREDIENTS

<u>INGREDIENT NAME</u>	<u>CAS NUMBER</u>	<u>WEIGHT %</u>
Pentafluoroethane (HFC-125)	354-33-6	44
1,1,1-Trifluoroethane (HFC-143a)	420-46-2	52
1,1,1,2-Tetrafluoroethane (HFC-134a)	811-97-2	4

Trace impurities and additional material names not listed above may also appear in Section 15 toward the end of the MSDS. These materials may be listed for local "Right-To-Know" compliance and for other reasons.

3. HAZARDS IDENTIFICATION

EMERGENCY OVERVIEW: Colorless, volatile liquid with ethereal and faint sweetish odor. Non-flammable material. Overexposure may cause dizziness and loss of concentration. At higher levels, CNS depression and cardiac arrhythmia may result from exposure. Vapors displace air and can cause asphyxiation in confined spaces. At higher temperatures, (>250°C), decomposition products may include Hydrofluoric Acid (HF) and carbonyl halides.

POTENTIAL HEALTH HAZARDS

SKIN: Irritation would result from a defatting action on tissue. Liquid contact could cause frostbite.

EYES: Liquid contact can cause severe irritation and frostbite. Mist may irritate.

INHALATION: R-404A is low in acute toxicity in animals. When oxygen levels in air are reduced to 12-14% by displacement, symptoms of asphyxiation, loss of coordination, increased pulse rate and deeper respiration will occur. At high levels, cardiac arrhythmia may occur.

R-404A Refrigerant Material Safety Data Sheet, continued

NATIONAL REFRIGERANTS™

R-404A

INGESTION: Ingestion is unlikely because of the low boiling point of the material. Should it occur, discomfort in the gastrointestinal tract from rapid evaporation of the material and consequent evolution of gas would result. Some effects of inhalation and skin exposure would be expected.

DELAYED EFFECTS: None known.

Ingredients found on one of the OSHA designated carcinogen lists are listed below.

<u>INGREDIENT NAME</u>	<u>NTP STATUS</u>	<u>IARC STATUS</u>	<u>OSHA LIST</u>
No ingredients listed in this section			

4. FIRST AID MEASURES

SKIN: Promptly flush skin with water until all chemical is removed. If there is evidence of frostbite, bathe (do not rub) with lukewarm (not hot) water. If water is not available, cover with a clean, soft cloth or similar covering. Get medical attention if symptoms persist.

EYES: Immediately flush eyes with large amounts of water for at least 15 minutes (in case of frostbite water should be lukewarm, not hot) lifting eyelids occasionally to facilitate irrigation. Get medical attention if symptoms persist.

INHALATION: Immediately remove to fresh air. If breathing has stopped, give artificial respiration. Use oxygen as required, provided a qualified operator is available. Get medical attention. Do not give epinephrine (adrenaline).

INGESTION: Ingestion is unlikely because of the physical properties and is not expected to be hazardous. Do not induce vomiting unless instructed to do so by a physician.

ADVICE TO PHYSICIAN: Because of the possible disturbances of cardiac rhythm, catecholamine drugs, such as epinephrine, should be used with special caution and only in situations of emergency life support. Treatment of overexposure should be directed at the control of symptoms and the clinical conditions.

5. FIRE FIGHTING MEASURES

FLAMMABLE PROPERTIES

FLASH POINT:	Gas, not applicable per DOT regulations
FLASH POINT METHOD:	Not applicable
AUTOIGNITION TEMPERATURE:	<750°C
UPPER FLAME LIMIT (volume % in air):	None*
LOWER FLAME LIMIT (volume % in air):	None*
	*Based on ASHRAE Standard 34 with match ignition
FLAME PROPAGATION RATE (solids):	Not applicable
OSHA FLAMMABILITY CLASS:	Not applicable

EXTINGUISHING MEDIA:

Use any standard agent – choose the one most appropriate for type of surrounding fire (material itself is not flammable)

NATIONAL REFRIGERANTS™

R-404A

UNUSUAL FIRE AND EXPLOSION HAZARDS:

R-404A is not flammable at ambient temperatures and atmospheric pressure. However, this material will become combustible when mixed with air under pressure and exposed to strong ignition sources. Contact with certain reactive metals may result in formation of explosive or exothermic reactions under specific conditions (e.g. very high temperatures and/or appropriate pressures).

SPECIAL FIRE FIGHTING PRECAUTIONS/INSTRUCTIONS:

Firefighters should wear self-contained, NIOSH-approved breathing apparatus for protection against possible toxic decomposition products. Proper eye and skin protection should be provided. Use water spray to keep fire-exposed containers cool.

6. ACCIDENTAL RELEASE MEASURES

IN CASE OF SPILL OR OTHER RELEASE:

(Always wear recommended personal protective equipment.)

Evacuate unprotected personnel. Protected personnel should remove ignition sources and shut off leak, if without risk, and provide ventilation. Unprotected personnel should not return until air has been tested and determined safe, including low-lying areas.

Spills and releases may have to be reported to Federal and/or local authorities. See Section 15 regarding reporting requirements.

7. HANDLING AND STORAGE

NORMAL HANDLING:

(Always wear recommended personal protective equipment.)

Avoid breathing vapors and liquid contact with eyes, skin or clothing. Do not puncture or drop cylinders, expose them to open flame or excessive heat. Use authorized cylinders only. Follow standard safety precautions for handling and use of compressed gas cylinders.

R-404A should not be mixed with air above atmospheric pressure for leak testing or any other purpose.

STORAGE RECOMMENDATIONS:

Store in a cool, well-ventilated area of low fire risk and out of direct sunlight. Protect cylinder and its fittings from physical damage. Storage in subsurface locations should be avoided. Close valve tightly after use and when empty.

8. EXPOSURE CONTROLS / PERSONAL PROTECTION

ENGINEERING CONTROLS:

Provide local ventilation at filling zones and areas where leakage is probable. Mechanical (general) ventilation may be adequate for other operating and storage areas.

PERSONAL PROTECTIVE EQUIPMENT

SKIN PROTECTION:

Skin contact with refrigerant may cause frostbite. General work clothing and gloves (leather) should provide adequate protection. If prolonged contact with the liquid or gas is anticipated, insulated gloves constructed of PVA, neoprene or butyl rubber should be used. Any contaminated clothing should be promptly removed and washed before reuse.

R-404A Refrigerant Material Safety Data Sheet, continued

NATIONAL REFRIGERANTS TM
--

R-404A**EYE PROTECTION:**

For normal conditions, wear safety glasses. Where there is reasonable probability of liquid contact, wear chemical safety goggles.

RESPIRATORY PROTECTION:

None generally required for adequately ventilated work situations. For accidental release or non-ventilated situations, or release into confined space, where the concentration may be above the PEL of 1,000 ppm, use a self-contained, NIOSH-approved breathing apparatus or supplied air respirator. For escape: use the former or a NIOSH-approved gas mask with organic vapor canister.

ADDITIONAL RECOMMENDATIONS:

Where contact with liquid is likely, such as in a spill or leak, impervious boots and clothing should be worn. High dose-level warning signs are recommended for areas of principle exposure. Provide eyewash stations and quick-drench shower facilities at convenient locations. For tank cleaning operations, see OSHA regulations, 29 CFR 1910.132 and 29 CFR 1910.133.

EXPOSURE GUIDELINES

<u>INGREDIENT NAME</u>	<u>ACGIH TLV</u>	<u>OSHA PEL</u>	<u>OTHER LIMIT</u>
Pentafluoroethane	None	None	*1000 ppm TWA (8hr)
1,1,1-Trifluoroethane	None	None	*1000 ppm TWA (8hr)
1,1,1,2-Tetrafluoroethane	None	None	*1000 ppm TWA (8hr)

* = Workplace Environmental Exposure Level (AIHA)

OTHER EXPOSURE LIMITS FOR POTENTIAL DECOMPOSITION PRODUCTS:

Hydrogen Fluoride: ACGIH TLV: 3 ppm ceiling

9. PHYSICAL AND CHEMICAL PROPERTIES

APPEARANCE:	Clear, colorless liquid and vapor
PHYSICAL STATE:	Gas at ambient temperatures
MOLECULAR WEIGHT:	120
CHEMICAL FORMULA:	CHF ₂ CF ₃ , CH ₃ CF ₃ , CH ₂ FCF ₃
ODOR:	Faint ethereal odor
SPECIFIC GRAVITY (water = 1.0):	1.08 @ 21.1°C (70°F)
SOLUBILITY IN WATER (weight %):	Unknown
pH:	Neutral
BOILING POINT:	-47.8°C (-54.0°F)
FREEZING POINT:	Not Determined
VAPOR PRESSURE:	182.9 psia @ 70°F 370.9 psia @ 130°F
VAPOR DENSITY (air = 1.0):	3.43
EVAPORATION RATE:	>1
% VOLATILES:	100
FLASH POINT:	Not applicable
(Flash point method and additional flammability data are found in Section 5.)	
	COMPARED TO: CC1₄ = 1

NATIONAL REFRIGERANTS™

R-404A

10. STABILITY AND REACTIVITY

NORMALLY STABLE? (CONDITIONS TO AVOID):

The product is stable.

Do not mix with oxygen or air above atmospheric pressure. Any source of high temperature, such as lighted cigarettes, flames, hot spots or welding may yield toxic and/or corrosive decomposition products.

INCOMPATIBILITIES:

(Under specific conditions: e.g. very high temperatures and/or appropriate pressures) – Freshly abraded aluminum surfaces (may cause strong exothermic reaction). Chemically active metals: potassium, calcium, powdered aluminum, magnesium and zinc.

HAZARDOUS DECOMPOSITION PRODUCTS:

Halogens, halogen acids and possibly carbonyl halides.

HAZARDOUS POLYMERIZATION:

Will not occur.

11. TOXICOLOGICAL INFORMATION

IMMEDIATE (ACUTE) EFFECTS:

HFC-125: LC₅₀ : 4 hr. (rat) - > 800,000 ppm / Cardiac Sensitization threshold (dog) 75,000 ppm
 HFC-143a: LC₅₀ : 4hr. (rat) - > 540,000 ppm / Cardiac Sensitization threshold (dog) > 250,000 ppm
 HFC-134a: LC₅₀ : 4hr. (rat) - > 500,000 ppm / Cardiac Sensitization threshold (dog) > 80,000 ppm

DELAYED (SUBCHRONIC AND CHRONIC) EFFECTS:

HFC-125: Teratogenic NOEL (rat and rabbit) – 50,000 ppm
 Subchronic inhalation (rat) NOEL - \geq 50,000 ppm / Chronic NOEL – 10,000 ppm
 HFC-143a: Teratogenic NOEL (rat and rabbit) – 50,000 ppm
 Subchronic inhalation (rat) NOEL - \geq 50,000 ppm
 HFC-134a: Teratogenic NOEL (rat and rabbit) – 40,000 ppm
 Subchronic inhalation (rat) NOEL – 50,000 ppm / Chronic NOEL – 10,000 ppm

OTHER DATA:

HFC-125, HFC-134a: Not active in four genetic studies
 HFC-143a: Not active in two genetic studies

12. ECOLOGICAL INFORMATION

Degradability (BOD): R-404A is a gas at room temperature; therefore, it is unlikely to remain in water.

Octanol Water Partition Coefficient: Unknown for mixture

R-404A Refrigerant Material Safety Data Sheet, continued

**NATIONAL
REFRIGERANTS™**

R-404A**13. DISPOSAL CONSIDERATIONS****RCRA**

Is the unused product a RCRA hazardous waste if discarded? Not a hazardous waste.
If yes, the RCRA ID number is: Not applicable.

OTHER DISPOSAL CONSIDERATIONS:

Disposal must comply with federal, state, and local disposal or discharge laws. R-404A is subject to U.S. Environmental Protection Agency Clean Air Act Regulations Section 608 in 40 CFR Part 82 regarding refrigerant recycling.

The information offered here is for the product as shipped. Use and/or alterations to the product such as mixing with other materials may significantly change the characteristics of the material and alter the RCRA classification and the proper disposal method.

14. TRANSPORT INFORMATION

US DOT PROPER SHIPPING NAME: Refrigerant gas R 404A
US DOT HAZARD CLASS: 2.2
US DOT PACKING GROUP: Not applicable
US DOT ID NUMBER: UN3337

For additional information on shipping regulations affecting this material, contact the information number found in Section 1.

15. REGULATORY INFORMATION**TOXIC SUBSTANCES CONTROL ACT (TSCA)**

TSCA INVENTORY STATUS: Components listed on the TSCA inventory
OTHER TSCA ISSUES: None

SARA TITLE III / CERCLA

“Reportable Quantities” (RQs) and/or “Threshold Planning Quantities” (TPQs) exist for the following ingredients.

<u>INGREDIENT NAME</u>	<u>SARA / CERCLA RQ (lb.)</u>	<u>SARA EHS TPO (lb.)</u>
No ingredients listed in this section		

Spills or releases resulting in the loss of any ingredient at or above its RQ requires immediate notification to the National Response Center [(800) 424-8802] and to your Local Emergency Planning Committee.

SECTION 311 HAZARD CLASS: IMMEDIATE PRESSURE

SARA 313 TOXIC CHEMICALS:

The following ingredients are SARA 313 “Toxic Chemicals”. CAS numbers and weight percents are found in Section 2.

<u>INGREDIENT NAME</u>	<u>COMMENT</u>
No ingredients listed in this section	

MSDS: R-404A
 Current Issue Date: December, 2008

Page 6 of 7

NATIONAL REFRIGERANTS™

R-404A

STATE RIGHT-TO-KNOW

In addition to the ingredients found in Section 2, the following are listed for state right-to-know purposes.

<u>INGREDIENT NAME</u>	<u>WEIGHT %</u>	<u>COMMENT</u>
No ingredients listed in this section		

ADDITIONAL REGULATORY INFORMATION:

R-404A is subject to U.S. Environmental Protection Agency Clean Air Act Regulations at 40 CFR Part 82.

WARNING: Contains Pentafluoroethane (HFC-125), 1,1,1-trifluoroethane, tetrafluoroethane, greenhouse gases which may contribute to global warming. **Do not vent** to the atmosphere. To comply with provisions of the U.S. Clean Air Act, any residual must be recovered.

WHMIS CLASSIFICATION (CANADA):

This product has been evaluated in accordance with the hazard criteria of the CPR and the MSDS contains all the information required by the CPR.

FOREIGN INVENTORY STATUS:

EU – EINECS # 2065578 – HFC-125
2069965 – HFC-143a
223770 – HFC-134a

16. OTHER INFORMATION

CURRENT ISSUE DATE: December, 2008
PREVIOUS ISSUE DATE: August, 2007

OTHER INFORMATION: HMIS Classification: Health – 1, Flammability – 1, Reactivity – 0
NFPA Classification: Health – 2, Flammability – 1, Reactivity – 0
ANSI / ASHRAE 34 Safety Group – A1

Regulatory Standards:

1. OSHA regulations for compressed gases: 29 CFR 1910.101
2. DOT classification per 49 CFR 172.101

Toxicity information per PAFT Testing

17. DISCLAIMER

National Refrigerants, Inc. believes that the information and recommendations contained herein (including data and statements) are accurate as of the date hereof. NO WARRANTY OF FITNESS FOR ANY PARTICULAR PURPOSE, WARRANTY OF MERCHANTABILITY, OR ANY OTHER WARRANTY, EXPRESSED OR IMPLIED, IS MADE CONCERNING THE INFORMATION PROVIDED HEREIN. The information provided herein relates only to the specific product designated and may not be valid where such product is used in combination with any other methods or use of the product and of the information referred to herein are beyond the control of National Refrigerants. National Refrigerants expressly disclaims any and all liability as to any results obtained or arising from any use of the product or reliance on such information.

MSDS: R-404A
Current Issue Date: December, 2008

Page 7 of 7

Wiring Diagram, 1/5 - 1/3 HP Models: 1 Phase, 120 Volt, 60 Hz

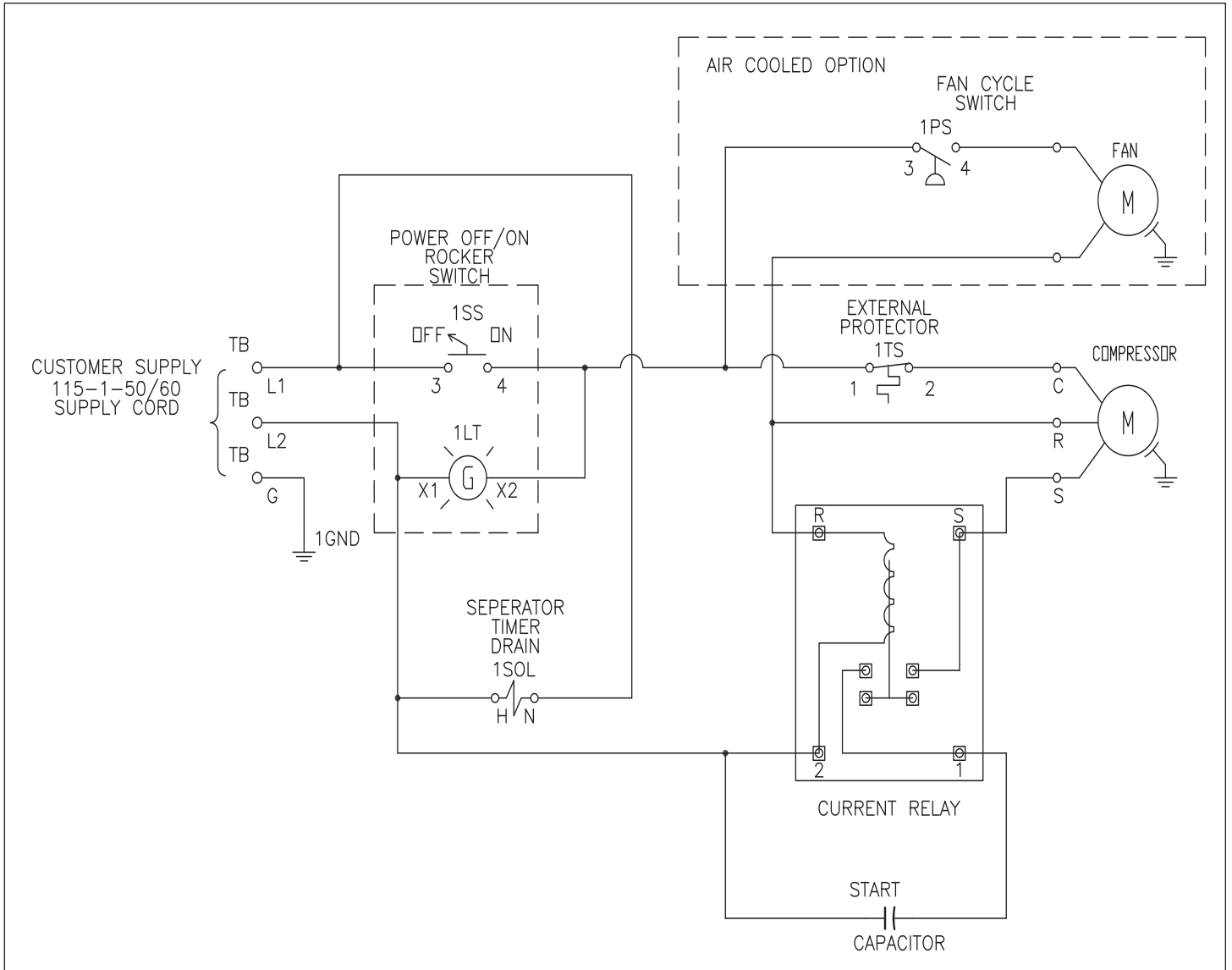

Wiring Diagram, 1/2 - 3/4 HP Models 1 Phase, 120 Volt, 60 Hz

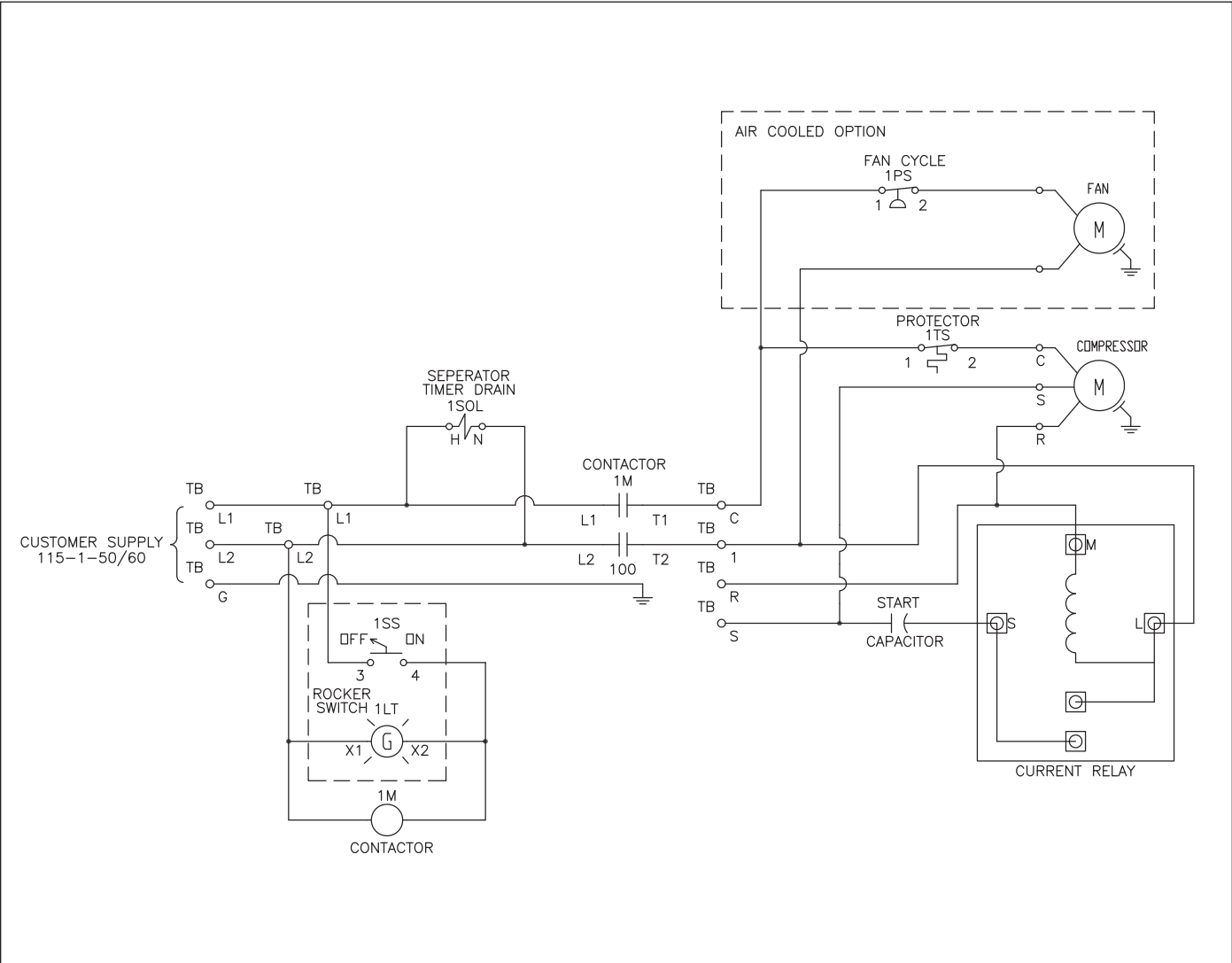

Wiring Diagram, 1-1/4 HP Models: 1 Phase, 208/230 Volt, 60 Hz

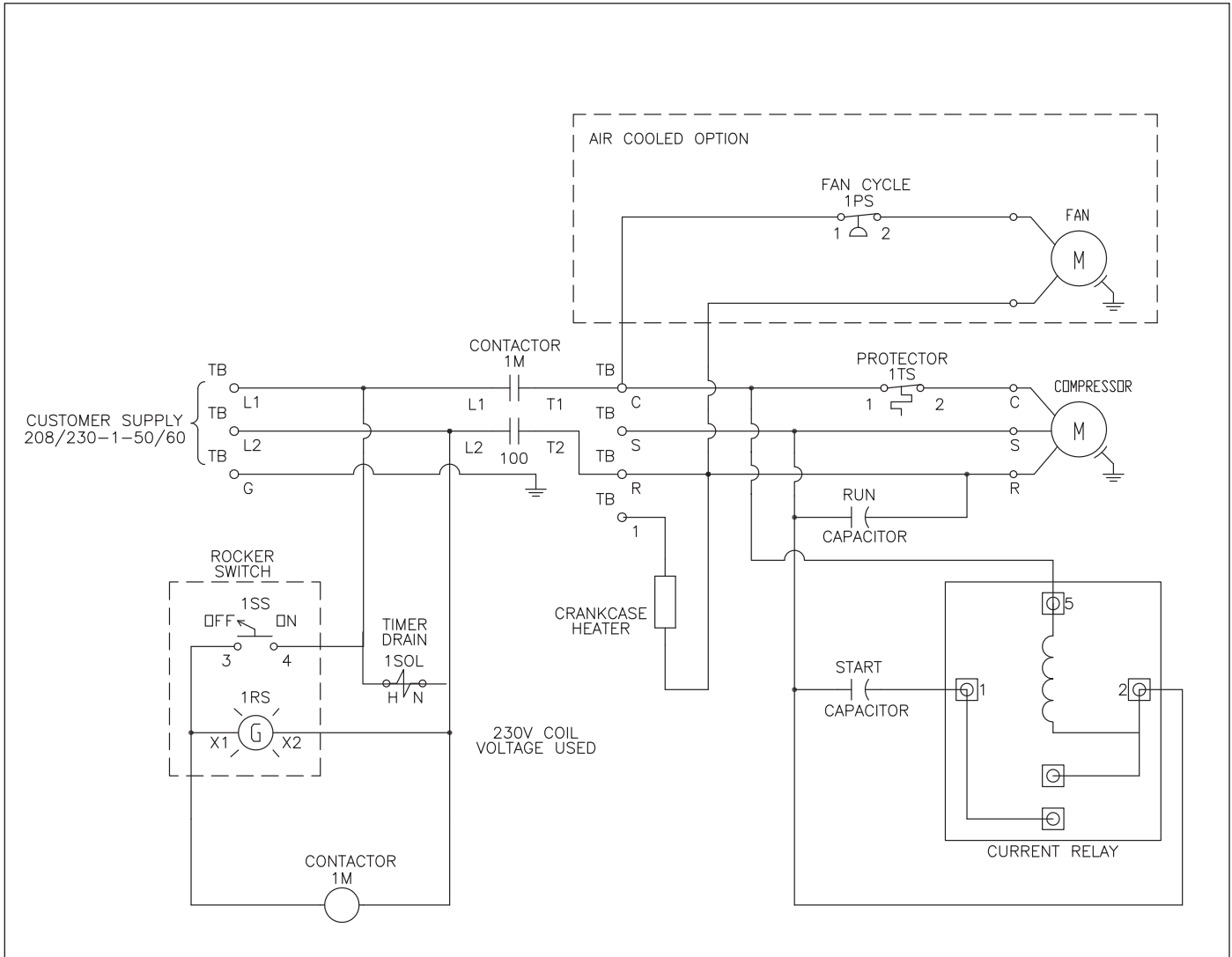

Wiring Diagram, 1-1/2 HP Models: 3 Phase, 230 Volt, 60 Hz

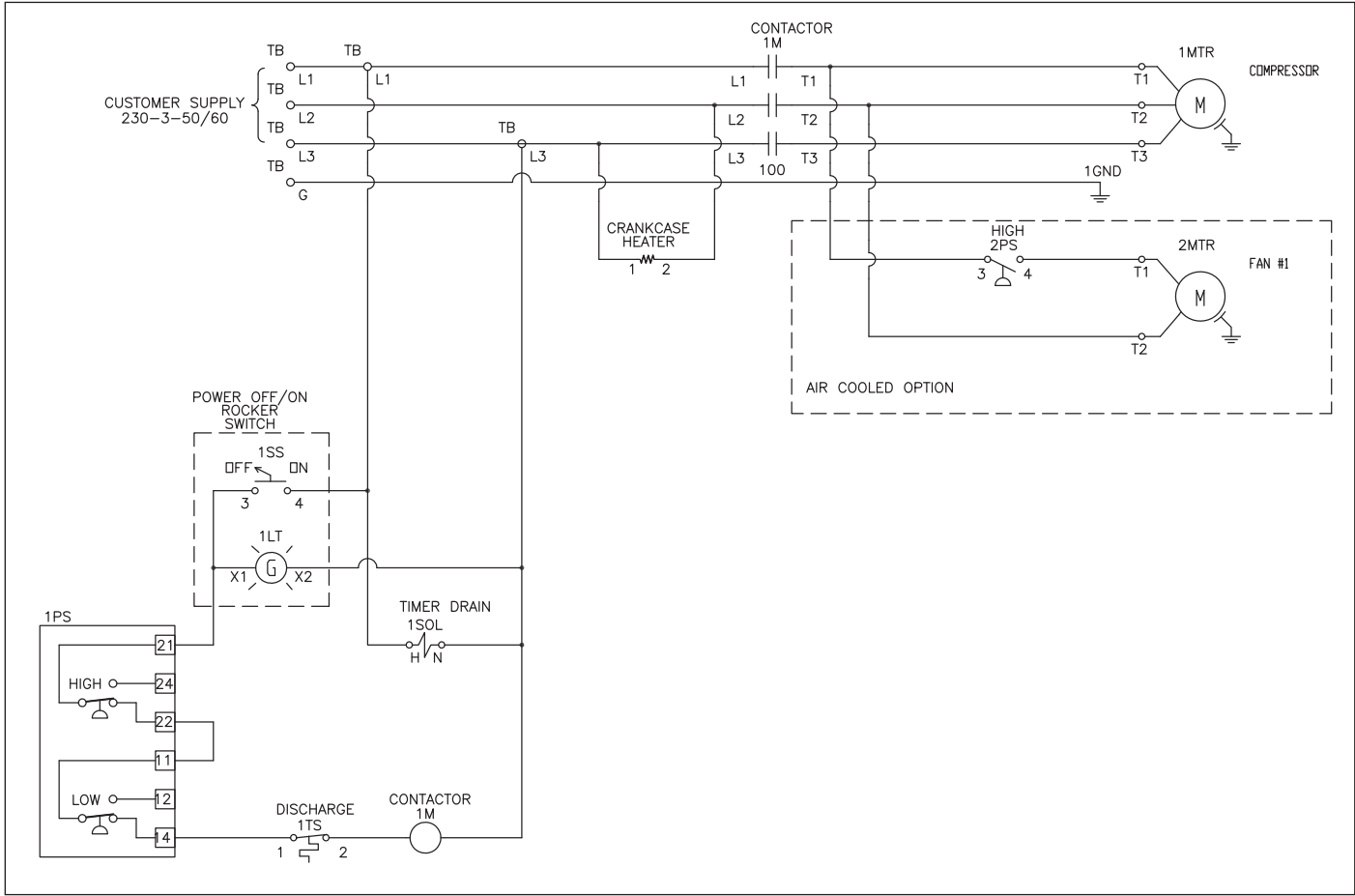

Wiring Diagram, 1-1/2: 3 Phase, 460 Volt, 60 Hz

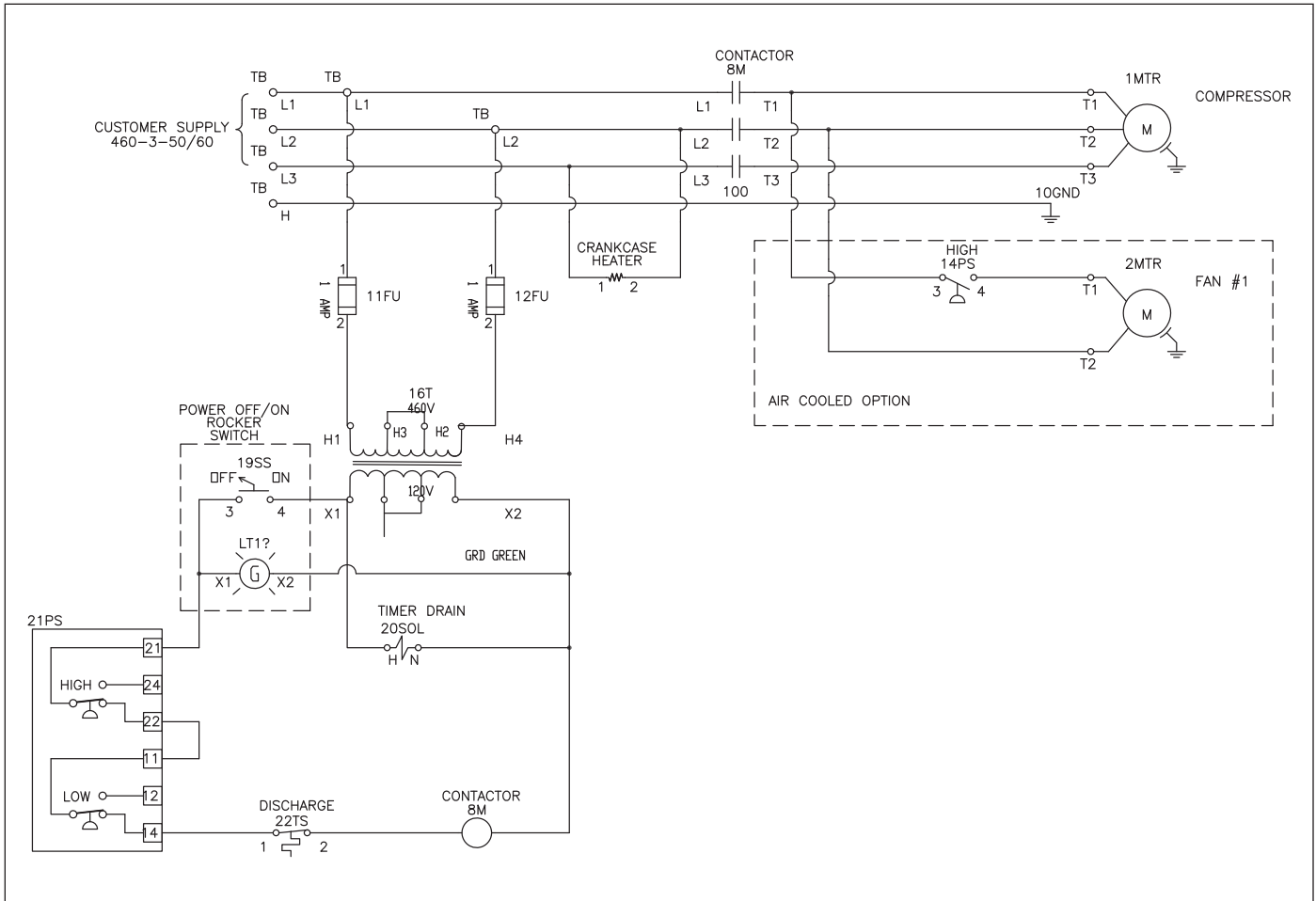

Wiring Diagram, 2-5 HP Models: 3 Phase, 460 Volt, 60 Hz

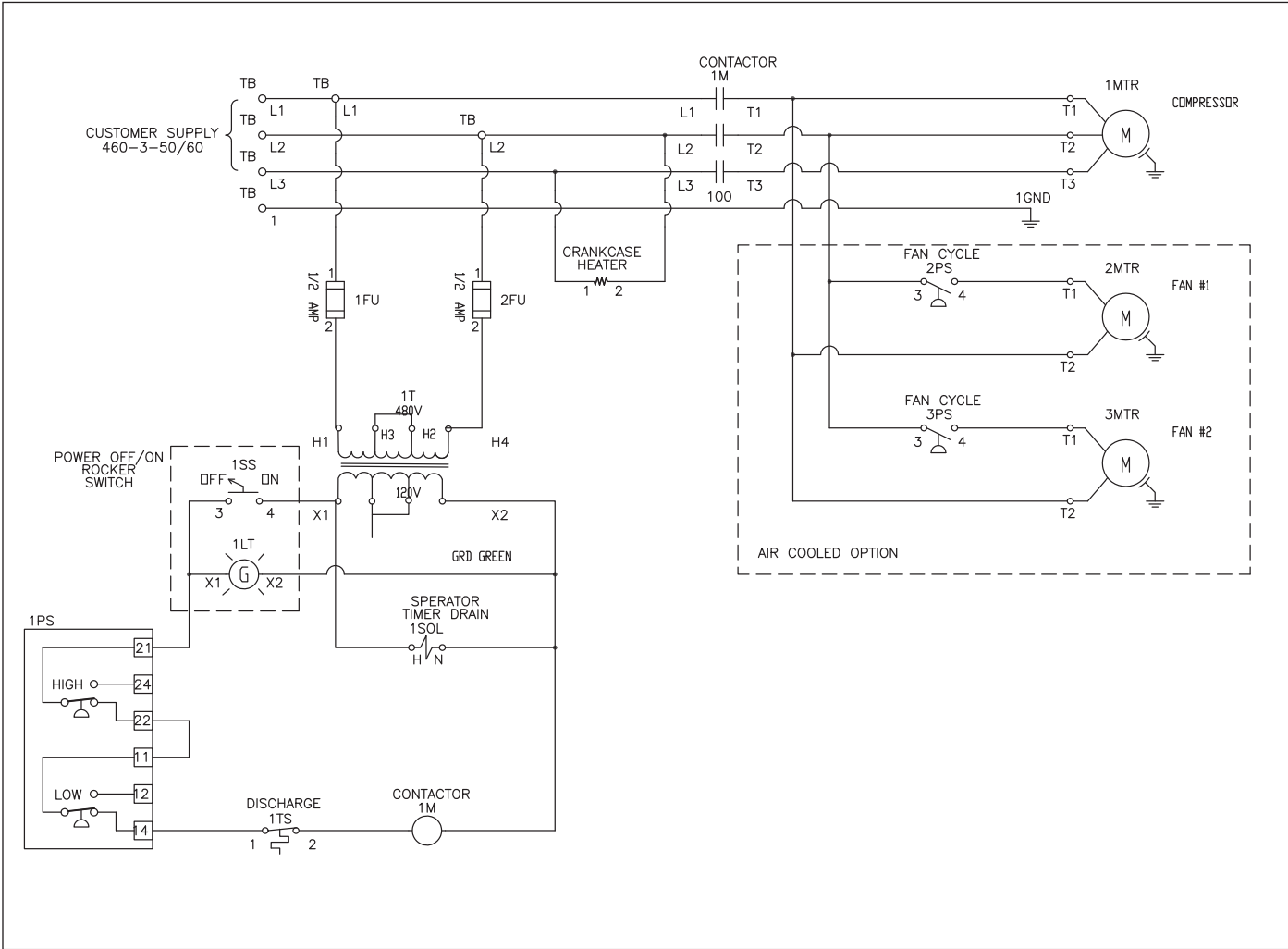

Aircel Compressed Air & Gas Warranty

The Manufacturer warrants its standard Refrigerated Dryers are free from defects in materials and workmanship for two years (1st year parts and labor, 2nd year parts only) from the date of invoice. Custom engineered products, desiccant air dryers, and nitrogen generators are warranted to be free from defects in materials and workmanship for one year (parts and labor coverage) from date of invoice. The Manufacturer Warranty excludes damages due to: corrosion, lack of proper maintenance, incorrect installation, modification, or misapplication of equipment. Routine maintenance or adjustments required under normal operation as outlined in the Manufacturer's operation and maintenance manuals are not covered under warranty. After the Manufacturer has been given adequate opportunity to remedy any defects in material or workmanship in accordance with Manufacturer's Warranty Policy and Procedures, the Manufacturer retains the sole option to accept the return of the goods, with freight paid by the purchaser, and to refund the purchase price for the goods after confirming the goods are returned undamaged and in usable condition. Such a refund will be the full extent of the Manufacturer's liability. The Manufacturer shall not be liable for any other costs, expenses or damages whether direct, indirect, special, incidental, consequential or otherwise. The terms of this warranty may be modified only by a special warranty document signed by the Director, General Manager or Vice President of the Manufacturer. **THERE EXIST NO OTHER REPRESENTATIONS, WARRANTIES OR GUARANTEES EXCEPT AS STATED IN THIS PARAGRAPH AND ALL OTHER WARRANTIES INCLUDING MERCHANTABILITY AND FITNESS FOR A PARTICULAR PURPOSE, WHETHER EXPRESS OR IMPLIED ARE HEREBY EXPRESSLY EXCLUDED AND DISCLAIMED.**

Parts and Service

For genuine Aircel replacement parts, call:

800-767-4599

www.airceldryers.com

For faster service, have unit's model and serial number, part number, description, and quantity available.



Aircel LLC.
323 Crisp Circle
Maryville, TN 37801
sales@airceldryers.com

Aircel LLC. is a leading designer and manufacturer of dryer systems and components.