

# nano

PURIFICATION SOLUTIONS



## **NBM - BREATHING AIR MODULE**

SERIES 2 & 3 BREATHING AIR USER GUIDE

<b>Contents</b>		<b>Page</b>
<b>1.</b>	<b>General information</b>	<b>3</b>
	1.1. Document introduction	3
	1.2. Support and Manufacturers details	3
	1.3. Warranty Guidelines	4
	1.4. Packaging	4
<b>2.</b>	<b>General safety</b>	<b>5</b>
	2.1. Intended Use	5
	2.2. Personnel	5
	2.3. Safe Handling	5
<b>3.</b>	<b>Technical Description</b>	<b>6</b>
<b>4.</b>	<b>Technical Specification</b>	<b>7</b>
	4.1 Product Specification	7
	4.2 Breathing Air Standards	7
	4.3 Maximum Flow Rates	8
	4.4 CO Alarm	8
<b>5.</b>	<b>Product Dimensions</b>	<b>9</b>
<b>6.</b>	<b>Equipment Overview</b>	<b>11</b>
<b>7.</b>	<b>System Layout</b>	<b>12</b>
	7.1. Typical Installation NBM-120 & 240	12
	7.2. Typical Installation NBM-480-960	12
	7.3. Site Location	13
	7.4. Risk Assessment	13
<b>8.</b>	<b>Purifier Operation</b>	<b>14</b>
	8.2. NBA Start-up	14
<b>9.</b>	<b>Maintenance</b>	<b>15</b>
	9.1. Maintenance guidelines	15
	9.2. Cleaning	15
	9.3. Daily checks	15
<b>10.</b>	<b>Servicing</b>	<b>16</b>
	10.1. Servicing Guidelines	16
	10.2. Servicing Intervals	17
<b>11.</b>	<b>Troubleshooting</b>	<b>18</b>
<b>12.</b>	<b>Commissioning Report</b>	<b>19</b>
<b>13.</b>	<b>Quality Statement</b>	<b>20</b>
<b>14.</b>	<b>Notes</b>	<b>21</b>

# 1. General Information

This manual is copyrighted, all rights reserved. It may not, in whole or in part, be copied, photocopied, reproduced, translated, or reduced to any electronic medium or machine readable form without prior consent in writing from nano-purification solutions Ltd. It may not be distributed through the internet or computer bulletin board systems without prior consent from nano-purification solutions Ltd.

**© 2017 nano-purification solutions Ltd.**  
**Product: Series 2 & 3 Breathing Air Module**  
**Document number: 17-110-1494**  
**Issue: 002**

## 1.1 Document Introduction

This manual provides factory prescribed installation and maintenance procedures for a nano-purification solutions (n-psi) breathing air module (NBM). The procedures illustrated in this document are only to be performed by competent personnel. For further information regarding the procedures outlined in this document contact nano-purification solutions before proceeding.

Read this document carefully before attempting to install or operate the Purifier. This document should be permanently available at the Purifier installation site and be kept in an easily accessible place alongside the Purifier.

## 1.2 Manufacturer's details and support

### nano-purification solutions ltd

Dukesway  
 Team Valley Trading Estate  
 Gateshead  
 NE11 0PZ  
 United Kingdom

**telephone:** +44 (0) 191 497 7700  
**web:** www.n-psi.co.uk  
**e-mail:** enquiries@n-psi.co.uk



### nano-purification solutions inc.

5509 David Cox Road  
 Charlotte, NC 28269  
 USA

**fax:** +1 (704) 897-2183  
**telephone:** +1 (704) 897-2182  
**web:** www.n-psi.com  
**e-mail:** support@n-psi.com

### Annotations:



**CAUTIONS:** indicate any situation or operation that may result in potential damage to the product, injury to the user, or render the product unsafe.



**NOTES:** highlight important sections of information where particular care and attention should be paid.

### 1.3 Warranty Guidelines

All products come with a 2 year manufacturer's warranty from the date of purchase, under the condition that it is installed and maintained in accordance with the manufacturer's guidelines. Only genuine service parts should be used and no modifications made. For further information please contact nano-purification solutions.

### 1.4 Packaging

All products are securely packaged in a specifically designed wooden packing box. The purifier will be held in a horizontal position by wooden struts; using straps to secure the product to the box base. The box top cover can be removed by removing all of the fixing screws and lifting it off in one piece.

#### Damage to Packaging

- Check immediately to establish whether damage has occurred to the external packaging and if the damage extends to the product inside.
- If there is damage to a product, contact the relevant supplier immediately.



**In no circumstances must a damaged product be used in operation. Using damaged products can lead to irreparable functional faults or cause serious physical harm.**

## 2. General safety



For your own safety, when carrying out work on this product, all relevant national safety regulations must be complied with relating to pressurized and breathing air systems. It is essential that a risk assessment is carried out prior to installation and use. See section 8.4 for guidance.

### 2.1. Intended use of the Product

The Purifier is exclusively intended for the treatment of compressed air, which is free from bulk water, oil and solid matter constituents.

The product should be located within a building and protected. The Purifier must be operated only in accordance with the data on the rating plate. Any operations that do not comply with those stated on the product rating label will render the warranty void.



**This product is only designed to operate at pressures of between 80 - 232 psig (5.5 - 16 barg).**

**It is not suitable for pressures in excess of 232 psig (16 barg).**



**IMPORTANT: It is essential that the system into which the Purifier is installed is fitted with a pressure limiting/relief device. This device should be between the compressor and the Purifier. The device must be set to prevent the maximum working pressure from being exceeded.**

No modifications must be made to the product. Any modifications may reduce the operational safety of the product and invalidate the manufacturer's warranty. This could potentially result in damage to the product rendering it unfit for its intended purpose and cause serious personal injury.

### 2.2. Personnel

Only authorized, competent and trained personnel are permitted to work on this product. This user guide is intended solely for such personnel and is to be used only as a reference; it should not be used to replace conventional training.

### 2.3. Safe Handling

Please ensure the relevant safe engineering practices and handling procedures are employed when handling, installing and operating this product. Ensure that the equipment is depressurized prior to carrying out any of the scheduled maintenance according to instructions specified within this user guide.



*A suitable lifting aid must be used to minimise the risk of physical injury or damage to the product.*

### 3. Technical Description

The nano-purification solutions Breathing Air Module (NBM) is designed for use in existing systems where a properly maintained desiccant dryer and appropriate filtration is already installed. For a complete purifier package, please refer to the B1 Series Compressed Breathing Air Purifiers, or contact nano-purification solutions before proceeding. When used in the appropriate system, the NBM Purifier Modules are designed to provide a continuous supply range of breathable air to meet the most exacting standards world-wide. The design incorporates several stages of purification in one simple to service cartridge, reducing the cost of ownership and simplifying maintenance.

Atmospheric air contains a number of contaminants which must be removed to ensure the provision of high purity breathable air. Contaminants present include dirt, water, oil, hydrocarbon vapors, bacteria and toxic gases such as CO, NO<sub>2</sub> and SO<sub>2</sub>.

The nano breathing air module is a static adsorber, which employs two purification stages to ensure breathable compressed air is produced from a typical compressed air supply.

The purifier must be preceded by inlet filtration which removes dirt, bulk water and oil aerosols and a heatless desiccant air dryer which delivers air to -40°F pressure dewpoint. For advice on the required inlet air quality of the purifier please refer to the specification on page 7 or contact Nano Purification Solutions.

The purifier removes HydroCarbon Vapors and reduces CO to specified levels through adsorbent and catalyst stages contained within removable cartridges. The cartridges are non-regenerative and should be replaced periodically inline with the product service schedule on page 17.

## 4. Technical Specification

### 4.1 Product Specification

	EUROPEAN & NORTH AMERICAN SPECIFICATION	CANADIAN SPECIFICATION
<b>Required Inlet Purity</b>	ISO 8573-1 : 2010 Class 1.2.1	ISO 8573-1 : 2010 Class 1.2.1
<b>Minimum working pressure</b>	80 psig (5.5 barg)	80 psig (5.5 barg)
<b>Maximum working pres-</b>	232 psig (16 barg)	217.5 psig (15 barg)
<b>Minimum inlet temperature</b>	34.7°F (1.5°C)	34.7°F (1.5°C)
<b>Maximum inlet temperature</b>	86°F (30°C)	86°F (30°C)

### 4.2 Breathing Air Standards

Impurity	European Pharma	CSA Z180.1
*CO <sub>2</sub>	<500ppm	<500ppm
*CO	<5ppm	<5ppm
SO <sub>2</sub>	<1ppm	NA
NO <sub>2</sub>	<2ppm	NA
O <sub>2</sub>	NA	20-22%
N <sub>2</sub> & Rare Gases	NA	78-80%
Water Vapour	ADP -45°C (-49°F) (-23°F) -31°C at 7 bar (100psi)	At a dew point 5°C under the lowest temperature its exposed to during the year.
Oil vapour	<0.01 mg/m <sup>3</sup>	<1mg/m <sup>3</sup>
Dirt Particles	NA	<1mg/m <sup>3</sup>
Odor	Taste and odour free	Taste and odour free
Bacteria	NA	NA
Methane	NA	<10ppm
Volatile non-methane hydrocarbons (VNMH)	NA	<5ppm
Volatile halogenated hydrocarbons	NA	<5ppm

<b>Europe</b>	EN12021
<b>UK</b>	BS4275 : 1997
<b>USA</b>	CGA G7.1-1997 OSHA-Grade D
<b>Canada</b>	CSA Z180.1



Refer to section 11.3 on page 18 regarding sampling and maintaining standards.

nano-purification solutions.



\*Where excessive levels of CO<sub>2</sub> and CO have been identified as the norm, breathing air purifiers should not be used and alternative strategies should be derived from a risk assessment.  
When challenged with 750ppm  
When challenged with 65ppm



The breathing air module should be preceded by high efficiency filtration and a heatless desiccant dryer regardless of whether an oil or oil free compressor is used. Inlet air should be filtered and dried such that it complies with ISO 8573-1: 2010 quality class 1.2.1.

### 4.3 Maximum Flow Rates

Model	Maximum Flow Rate	
	NL/m	scfm
NBM - 120	3428.4	120
NBM - 240	6856.8	240
NBM - 480	13713.6	480
NBM - 720	20570.4	720
NBM - 960	27427.2	960

For flow rates at other pressures, apply the factor shown:

Line Pressure	bar g	5.5	6	7	8	9	10	11	12	13	14	15	16
	psi g	80	87	102	116	131	145	160	174	189	203	218	232
<b>Correction Factor</b>		0.89	0.92	1	1.07	1.13	1.20	1.25	1.31	1.36	1.41	1.46	1.51

### 4.4 CO Alarm

According to OSHA 1910.134 and CSA Z180.1, a CO monitor and alarm should be fitted to monitor the outlet air purity.



## 5. Product Dimensions

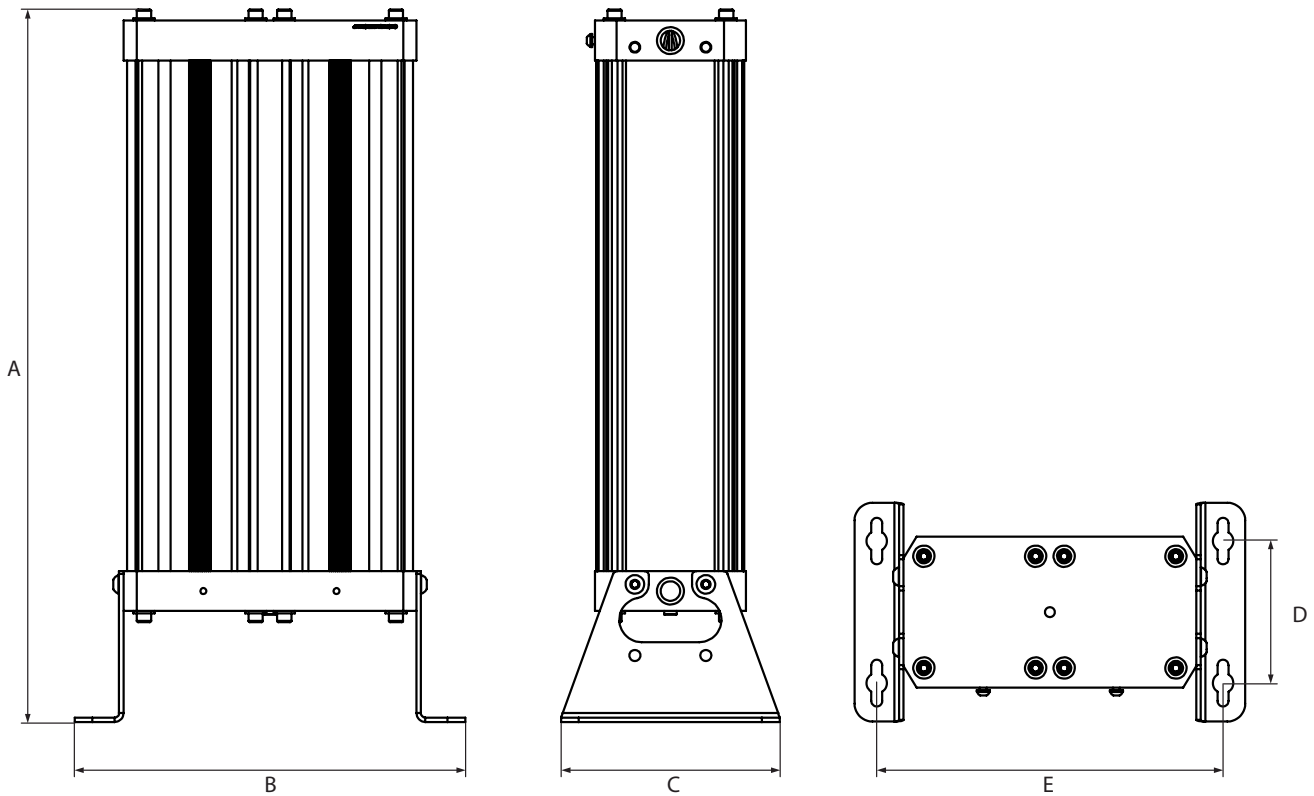

Model	Connection (BSP or NPT)	Dimension					Weight kg (lbs)
		A mm (ins)	B mm (ins)	C mm (ins)	D mm (ins)	E mm (ins)	
<b>NBM-120</b>	<b>1"</b> (Inlet & outlet)	<b>622.5</b> <b>(24.5)</b>	<b>440</b> <b>(17.3)</b>	<b>246.4</b> <b>(9.7)</b>	<b>160</b> <b>(6.3)</b>	<b>390</b> <b>(15.4)</b>	<b>38</b> <b>(84)</b>
<b>NBM-240</b>	<b>1"</b> (Inlet & outlet)	<b>805.5</b> <b>(31.6)</b>	<b>440</b> <b>(17.3)</b>	<b>246.4</b> <b>(9.7)</b>	<b>160</b> <b>(6.3)</b>	<b>390</b> <b>(15.4)</b>	<b>45</b> <b>(100)</b>

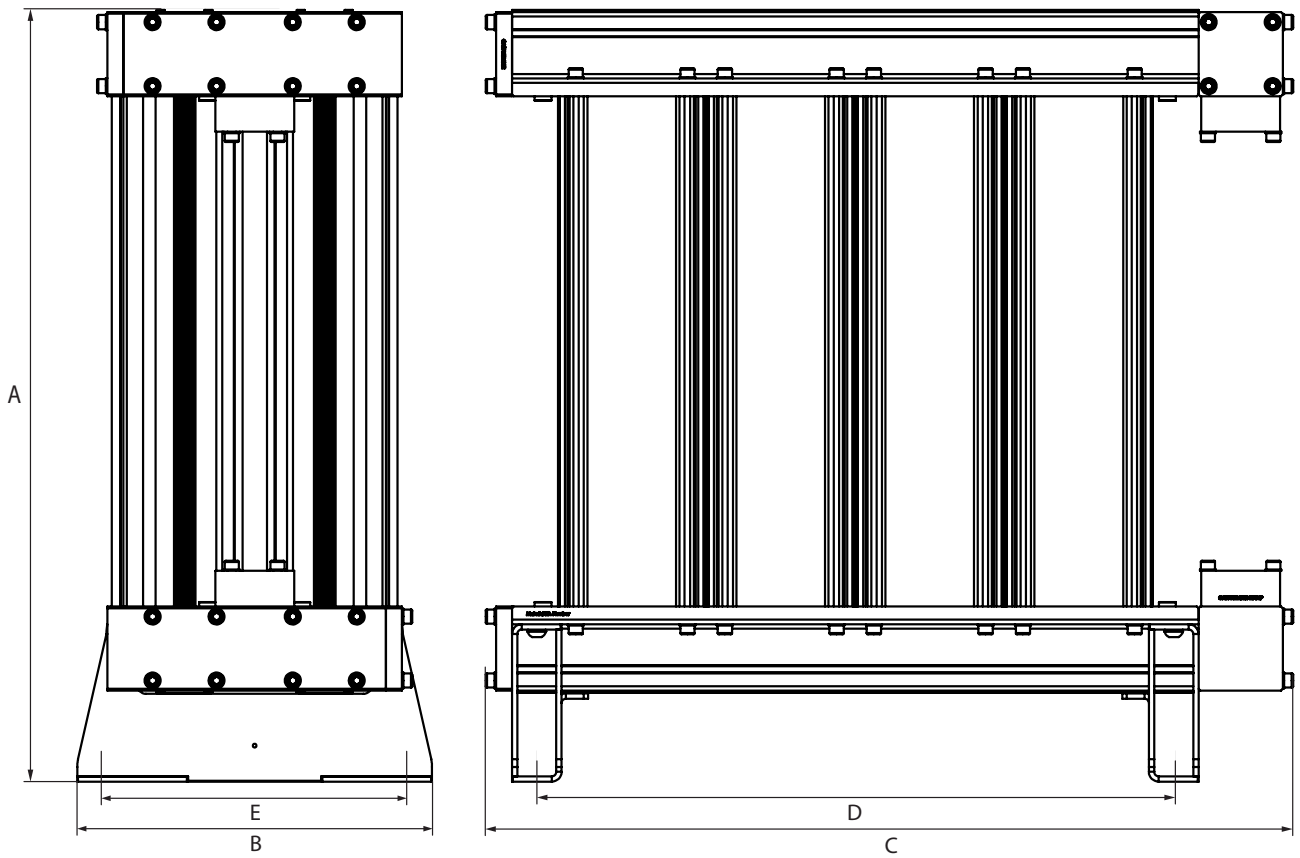

Model	Connection (BSP or NPT)	Dimension					Weight kg (lbs)
		A mm (ins)	B mm (ins)	C mm (ins)	D mm (ins)	E mm (ins)	
<b>NBM-480</b>	<b>2"</b> (Inlet & outlet)	<b>870</b> <b>(34.3)</b>	<b>400</b> <b>(15.7)</b>	<b>574.2</b> <b>(22.6)</b>	<b>382</b> <b>(15)</b>	<b>360</b> <b>(14.2)</b>	<b>103</b> <b>(227)</b>
<b>NBM-720</b>	<b>2"</b> (Inlet & outlet)	<b>870</b> <b>(34.3)</b>	<b>400</b> <b>(15.7)</b>	<b>742.2</b> <b>(31.7)</b>	<b>550</b> <b>(21.7)</b>	<b>360</b> <b>(14.2)</b>	<b>142</b> <b>(313)</b>
<b>NBM-960</b>	<b>2<sup>1/2</sup>"</b> (Inlet & outlet)	<b>870</b> <b>(34.3)</b>	<b>400</b> <b>(15.7)</b>	<b>910.2</b> <b>(35.8)</b>	<b>718</b> <b>(28.3)</b>	<b>360</b> <b>(14.2)</b>	<b>180</b> <b>(397)</b>

## 6. Equipment Overview

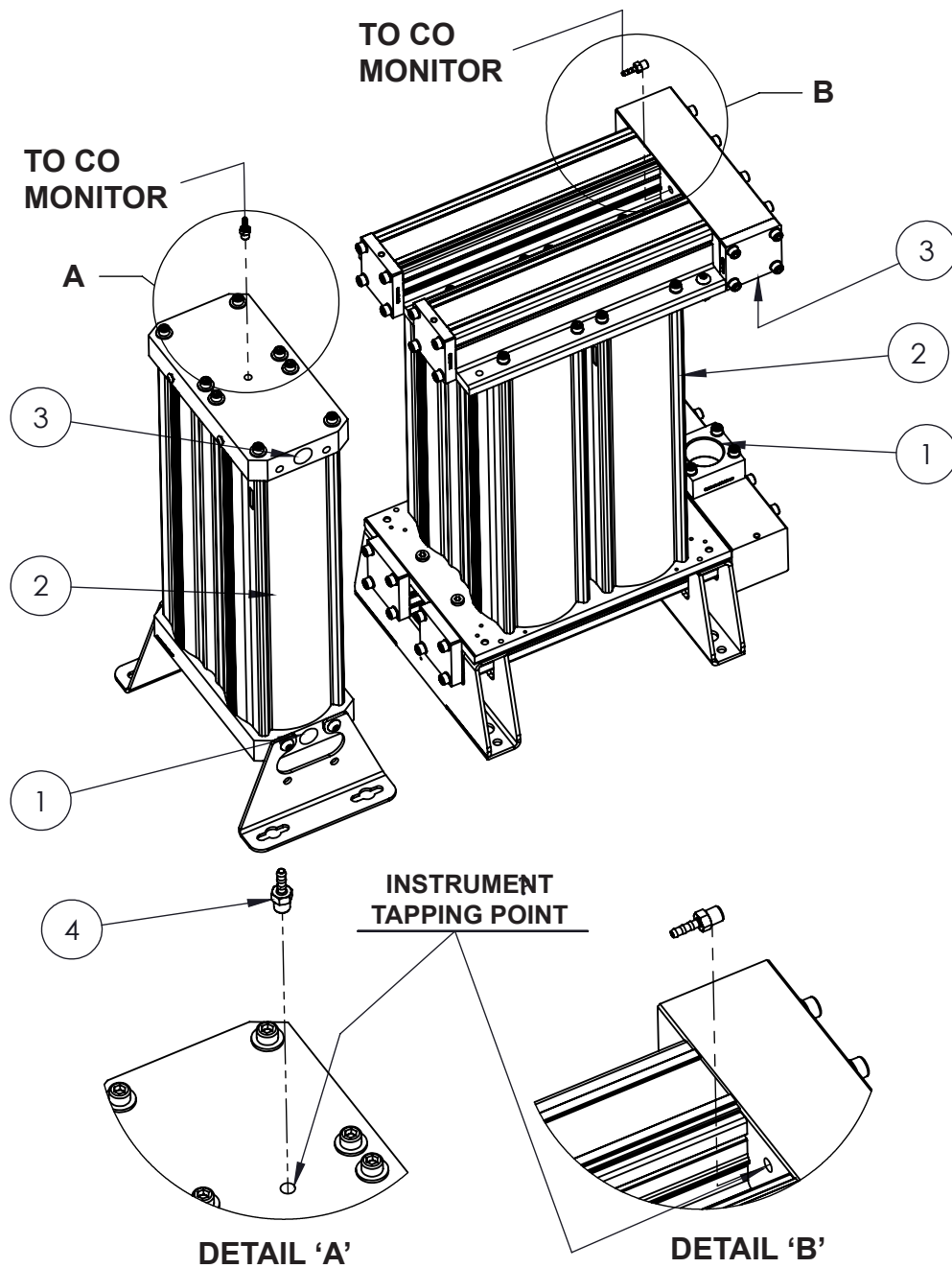

1	Air Inlet	3	Air Outlet
2	NBM Column	4	1/4" - 3/16" Hose Adaptor (Supplied) (BSP or NPT)

**NOTE:-**  
Item 4 not fitted but supplied with product.

## 7. System Layout

### 7.1. Typical installation NBM-120 - 240

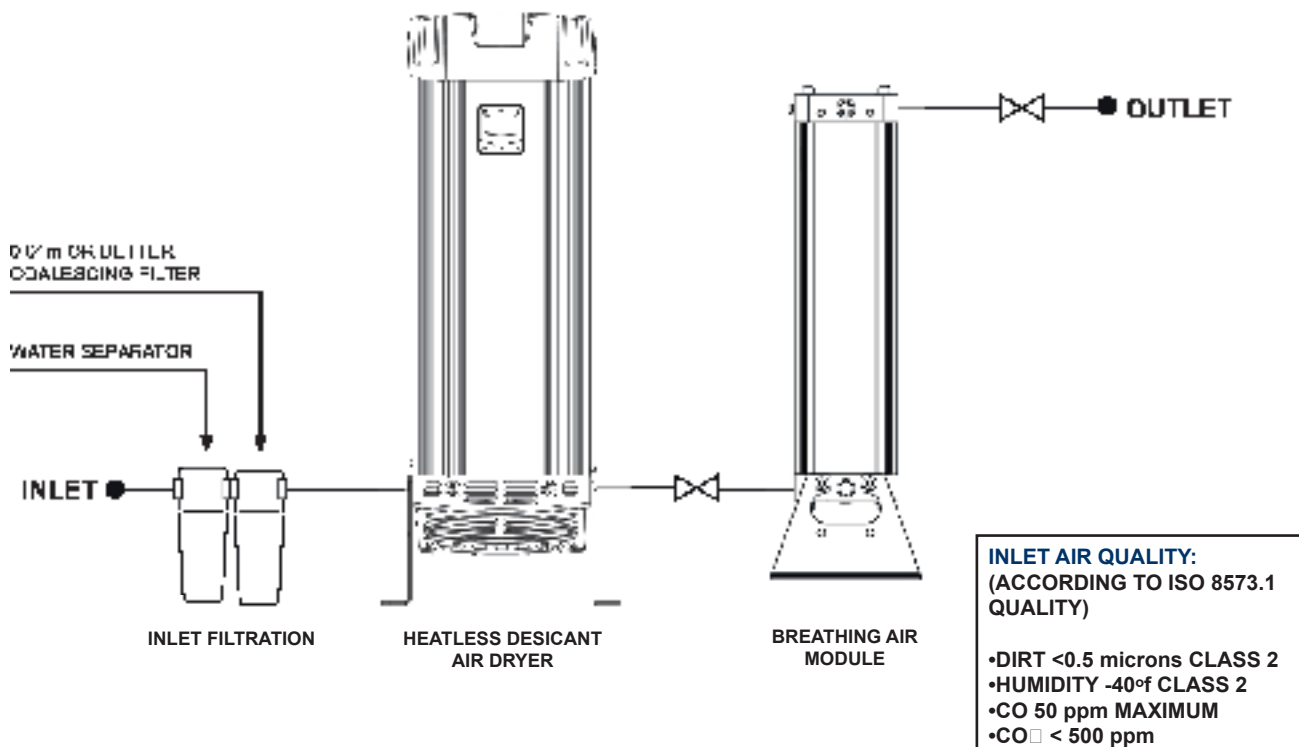

### 7.2. Typical installation NBM-480 -960

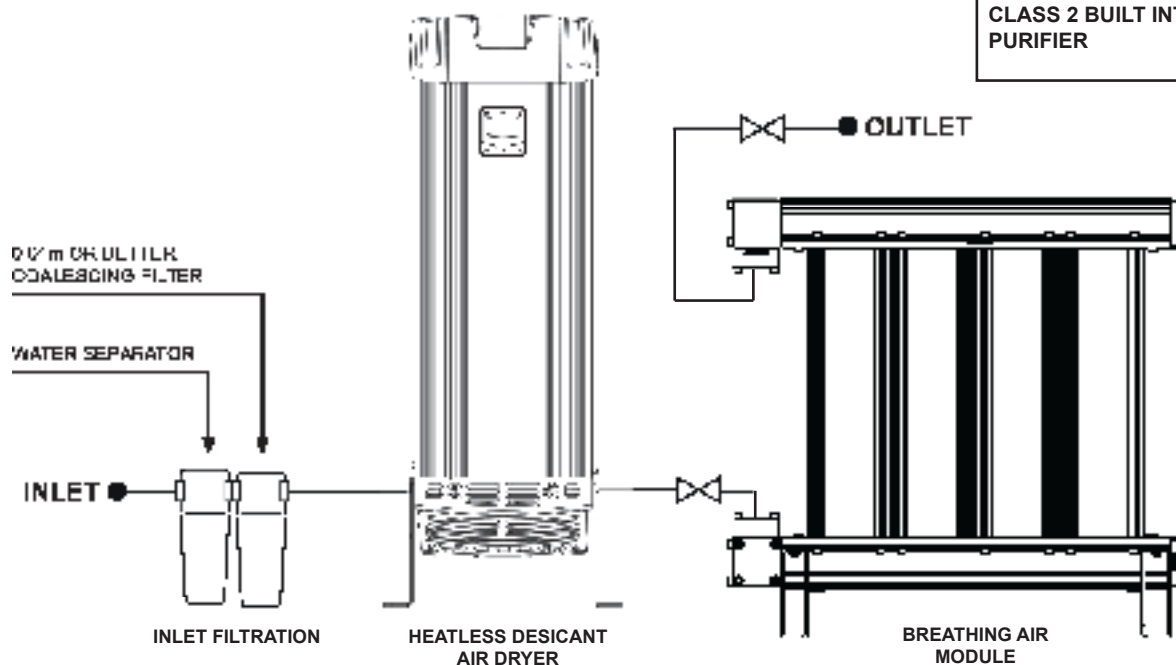

**IMPORTANT:** It is essential that the system into which the Module is installed is fitted with a pressure limiting/relief device. This device should be between the compressor and the Purifier. The device must be set to prevent the maximum working pressure of 232 psig (16 barg) from being exceeded.

### 7.3. Site Location

When selecting an installation site for the Purifier, ensure the following conditions are met:

- Installation site should be located indoors on a flat surface protected from the weather and other harmful conditions.
- The ambient temperature must not drop below 34.7°F (+1.5°C) or exceed 86°F (30°C).
- The installation site should be level and able to support the weight of the product.
- Ensure sufficient space around the product, to allow access for operation and maintenance.

### 7.4. Risk Assessment

Prior to the installation a thorough risk assessment of the entire installation should be conducted by a competent person. Points listed below should be considered but should not be considered an exhaustive:

- Compressor type
- Pre-Filtration and Dryer suitability
- Condition of compressor/oil used if applicable
- Temperature and humidity
- Potential source of excessive contaminants e.g. toxic gases
- Use of a dedicated breathing air line if possible
- Purification equipment
- Alarm options
- Compliance to relevant regulations for pressured systems
- Comprehensive operator training
- Maintenance requirements



**The risk assessment should be carried out by competent personnel and checked and approved by a qualified engineer.**

## **8. Module Operation**

### **8.1. Purifier Start-up**

- Connect all pipe work, in line with the system layout on page 12.
- Ensure the inlet operating pressure parameters are correct (refer to specification on page 7).
- Ensure the inlet air temperature is correct (refer to specification on page 7).
- Slowly open the inlet valve until fully open and allow purifier to pressurize.
- Open the outlet valve to deliver breathable air.

## 9. Maintenance

### 9.1. Cleaning

Clean the equipment with a damp cloth and if required a mild detergent may be used, however do not use abrasives or solvents as they may cause damage.

### 9.2. Daily Checks

Visual and functional checks of the Purifier should be carried out daily:

- Check the Purifier for any external damage.  
**Assess and eliminate any defects found.**
- Remove any loose dust or dirt from the Purifier; clean all surfaces that appear to have attracted unwanted contaminants.
- Check the operation and readings on the CO monitor. Operate in accordance with suppliers instructions.

### 9.3. Sampling



**A sample of compressed breathing air produced and delivered by the compressed breathing air system must be collected and analyzed every 6 months (or as specified by the authority having jurisdiction) by an accredited lab. When the testing shows unacceptable levels of contaminants, the system must be taken out of service and reinspected.**

- Additional testing at regular intervals is recommended.
- Re-testing the system is recommended when any major overhaul or extensive repairs have been carried out.



**Any noticeable odor must be analyzed.**

## 10. Servicing



**Maintenance operations should only be carried out by authorized, competent and suitably trained personnel.**

### 10.1. Servicing Guidelines

- Maintenance operations only to be conducted when the system has been shut down, fully depressurized and isolated completely from the compressed air.
- Ensure the system is in a safe condition for maintenance to be carried out on.
- Dismantle and assemble with care, paying particular attention to the areas that become pressurized.
- All gaskets removed during maintenance operations must be replaced with new gaskets.
- Only certified n-psi approved replacement parts to be used.
- Always check all connections / sealing faces for cleanliness and secure seating prior to assembly.
- Ensure all components are refitted to the product before operation.
- Ensure the Purifier is left operating in a safe working condition after completion of maintenance.



## 10.1 Service Intervals

The following table details the recommended service intervals for this product.

The purifier should be serviced in accordance with the schedule outlined below. Failure to service the product as indicated and/or without genuine parts may damage the product, cause serious physical harm and will invalidate the manufacturer's warranty.



*Please refer to the product service guide for instruction regarding carrying out a service.*

- **Service Frequency - 8,000 hours (or every 1 year) service.**
- Replace all external filter elements (pre and post-filters)  
*(Please contact an n-psi representative for filter servicing information).*
- Replace adsorbent cartridges (NBMSK-120 & NBMSK-240)  
Replace all gaskets and seals removed while servicing the module (included in relevant service kits).

MODEL	SERVICE KIT	QUANTITY
NBM -120	NBMSK-120	1
NBM - 240	NBMSK-240	1
NBM - 480	NBMSK-240	2
NBM- 720	NBMSK-240	3
NBM-960	NBMSK-240	4

## 13. Troubleshooting

Problem	Problem Caused	Solutions
Poor performance	<ol style="list-style-type: none"> <li>Insufficient inlet pressure</li> <li>Moist or contaminated bed</li> <li>Too high air consumption</li> <li>Excessive inlet air temperature</li> </ol>	<ol style="list-style-type: none"> <li>Inlet pressure min 80 psig (5.5 barg). If not adjust inlet pressure settings.</li> <li>Eliminate the cause of contamination. Replace purification cartridges – do not re-use.</li> <li>Ensure the performance of the purifier matches the required system air consumption.</li> <li>Check against technical specification.</li> </ol>
Failure of purifier to cycle	<ol style="list-style-type: none"> <li>Outlet flow stops</li> </ol>	<ol style="list-style-type: none"> <li>Check inlet air supply.</li> </ol>

### Reference to known Fault:

#### Opening the inlet valve too quickly

Valve should be opened slowly allowing the pressure to build up gradually.

#### Inlet/outlet head pipe

Diameter too small.

Pipe work unsupported.

Inlet pipe work from low point in system, allowing water to collect and enter the Purifier.

#### Additional Items

Use of unauthorized components.

Untrained / non-authorized maintenance / installation personnel used.

Increase in air consumption without relation to the flow capacity of the Purifier.

Purging the Purifier with cleaning agents that could damage the components or the purification bed.

Covers removed or loose during operation.

Failure to carry out a service in line with the service schedule.

# 14. Commissioning Report

End User: \_\_\_\_\_ Distributor: \_\_\_\_\_  
 Contact: \_\_\_\_\_  
 Phone: \_\_\_\_\_  
 Email: \_\_\_\_\_

Contact name and position for the qualified user	Breathing Air Model	Serial Number	Compressor Make & Model
Contact:	Start-Up Date	Date	Location
Phone:			
Email:	Start-Up Technician	Technician Company	Technician Phone

Installation Details			Operating Details			Operating Notes		
Environment			Ambient Temp		°F/°C			
Receiver			Inlet Air Temp		°F/°C			
Inlet Flow Rate		scfm	Inlet Air Pressure		psig			
Filter Size			Outlet Pressure		psig			
Filter Grades			Dew Point Delivered/Witnessed	<input type="checkbox"/>	°F/°C			
Compressor Type			Carbon Monoxide (CO) Monitor Installed?	<input type="checkbox"/>				
Oil Type			CO Monitor Visible by User?	<input type="checkbox"/>				
Piping Type			CO Monitor Audible By User?	<input type="checkbox"/>				
Electrical			Is Compressor Dedicated to Breathing Air?	<input type="checkbox"/>				
Compressor Intake Location			Air quality Tested Before Installation?	<input type="checkbox"/>				
Local / Remote Control			Air Quality Tested After Installation?	<input type="checkbox"/>				
Drain Valves Size & Type			Air Quality Test Report Attached?	<input type="checkbox"/>				
Inlet / Outlet Pipe Size			Air Quality Test Report Posted?	<input type="checkbox"/>				
Dew Point Meter			User Guide Posted on Site?	<input type="checkbox"/>				
Check for Damage			Maintenance Items on Site?	<input type="checkbox"/>				

<b>Comments:</b>	Has this unit been installed according to manufacturers recommendations, passed a third party air quality test, and deemed suitable for operating by the installer? YES or NO.		
	<b>Start-up Check List</b>		
	Has the product been received in good condition?		
	Has the user received and reviewed the User Guide?		
	Has the user carried out the recommended Risk Assessment?		
	Is the product installed and operational?		
	Are there spare parts on site?		
	Has a daily check procedure been established?		
	Does the user require any assistance from nano-purification solutions?		

<b>Engineer:</b>		<b>Date:</b>		<b>I certify all of the above information to be true?</b>	<b>Yes/No</b>
------------------	--	--------------	--	---	---------------

**Note:** For an electronic version of this commissioning report, please download from our website at [www.n-psi.com](http://www.n-psi.com) in the "downloads – Breathing Air" section.

## 15. Quality Statement

All responsibility regarding quality of breathing air lies with the user. Compliance with any federal, state, provincial or local regulations are the sole responsibility of the user. All nano breathing air products meet or exceed the standards set forth in CGA Grade D specifications for air quality as set forth by OSHA (USA) and CSA Z180.1 (Canada).

When the breathing air equipment is used in accordance with the instructions as set forth by nano-purification solutions, the breathing air system meets or exceeds all breathing air standards currently in force. The user is responsible for installation and compliance with any localized regulations and should be up to date on any and all changes which may have occurred to specifications.

The air compressor needs to be located in a safe and clean ambient location and the location should be tested periodically to ensure the compressor is ingesting and compressing air suitable for downstream treatment by the breathing air system. The compressed air breathing system outlet quality should be tested at initial start-up and put on a preventative maintenance schedule of testing. If conditions or location of the breathing air system is to change, outlet breathing air should be retested and validated prior to use. Proper preventative maintenance of the system should be documented and maintained based on recommended maintenance of the manufacturer.

Grade-D (USA) or CSA Z180.1 testing (Canada) should be carried out and documented. These tests should analyze at a minimum: Carbon Monoxide, Oxygen, Carbon Dioxide, Water content, Hydrocarbon content and total particulate level. The actual allowable levels are clearly documented in the Technical Specification section.

When in doubt, please consult factory.

**nano-purification solutions ltd.**

Dukesway,  
Team Valley Trading Estate,  
Gateshead,  
NE11 0PZ  
United Kingdom

Telephone: +44 (0) 191 497 7700

Internet: [www.n-psi.co.uk](http://www.n-psi.co.uk)

E-mail: [enquiries@n-psi.co.uk](mailto:enquiries@n-psi.co.uk)

**nano-purification solutions inc.**

5509 David Cox Road  
Charlotte NC 28269  
USA

Telephone: +1 (704) 897-2182

Fax: +1 (704) 897-2183

Internet: [www.n-psi.com](http://www.n-psi.com)

E-mail: [support@n-psi.com](mailto:support@n-psi.com)



# Notes

.....

.....

.....

.....

.....

.....

.....

.....

.....

.....

.....

.....

.....

.....

.....

.....

.....

.....

.....

.....

.....

.....

.....

.....

.....



# **nano**

## **PURIFICATION SOLUTIONS**

**nano-purification solutions ltd.**

Dukesway,  
Team Valley Trading Estate,  
Gateshead,  
NE11 0PZ  
United Kingdom

Telephone: +44 (0) 191 497 7700

Internet: [www.n-psi.co.uk](http://www.n-psi.co.uk)

E-mail: [enquiries@n-psi.co.uk](mailto:enquiries@n-psi.co.uk)

**nano-purification solutions inc.**

5509 David Cox Road  
Charlotte NC 28269  
USA

Telephone: +1 (704) 897-2182

Fax: +1 (704) 897-2183

Internet: [www.n-psi.com](http://www.n-psi.com)

E-mail: [support@n-psi.com](mailto:support@n-psi.com)