

nano



## User Guide

# BPA blower purge desiccant air dryer

revision: 002 document: 117-110-8014

[www.n-psi.com](http://www.n-psi.com)

## Experience.

Our team is comprised of and supported by individuals spanning all disciplines from research & development, engineering & manufacturing, marketing & sales and service & support. Our backgrounds are in air and gas purification and our experience in this field spans a wide range of industries. We combine this knowledge and experience to ensure our products and services are designed and provided to meet the objectives and expectations of you - our Customer.



## Customer.

We recognize that our Customers are not only our valuable distribution partners who sell and support our products or the machine builders who depend on them as protection for their equipment. They are the contractors who install them, the manufacturers who use them in their processes and the service people who maintain them. At nano we have developed our products, packaging and support materials to ensure they exceed all of our Customers' expectations.



## Service.

At nano we recognize that world-class customer service is the most important component to any successful business. Your business needs to exceed your customers' expectations to stand out from your competitors and our service must positively impact your business so you can be successful in doing so. Our commitment is simple... we will stand behind our products and ensure that our customer service is unrivaled in the industry.



**Experience. Customer. Service.**

The logo for nano, consisting of the word "nano" in a stylized, lowercase, sans-serif font. The letters are bold and have a slight shadow effect. The logo is centered within a large, light gray circular frame.

# table of contents

<b>section</b>	<b>description</b>	<b>page</b>
<b>1</b>	<b>1.1</b> general information	4
	<b>1.2</b> manufacturers details and support	
	<b>1.3</b> document introduction	
	<b>1.4</b> warranty guidelines	5
	<b>1.5</b> definition of safety symbols	
	<b>1.6</b> general warnings	6
	<b>1.7</b> basic safety rules	7
	<b>1.8</b> qualified operators	9
	<b>1.9</b> storage	10
	<b>1.10</b> transport and handling	
	<b>1.11</b> proper use of the dryer	11
	<b>1.12</b> instructions for the use of pressure equipment	
<b>2</b>	<b>2.1</b> installation site	12
	<b>2.2</b> installation layout	13
	<b>2.3</b> dryer specifications	14
	<b>2.4</b> correction factors	
	<b>2.5</b> operation	15
	<b>2.6</b> recommendations for optimal performance	16
	<b>2.7</b> maintenance	17
<b>3</b>	<b>3.1</b> BPA operating sequence	19
	<b>3.2</b> operating three-valve bypass	21
	<b>3.3</b> setting purge pressure	23
	<b>3.4</b> operation of display screen	24
<b>4</b>	<b>4.1</b> trouble shooting	26
	<b>4.2</b> arrangement drawings	28
	<b>4.3</b> electrical drawings	30
	<b>4.4</b> appendixes	33



# blower purge desiccant air dryer

## 1.1 general information

This manual is copyrighted, all rights reserved. It may not, in whole or in part, be copied, photocopied, reproduced, translated, or reduced to any electronic medium or machine readable form without prior consent in writing from **nano-purification solutions**. It may not be distributed through the internet or computer bulletin board systems without prior consent from **nano-purification solutions**.

©2021 Air and Gas Solutions LLC

**range:** D<sup>5</sup> blower purge desiccant air dryers  
**models:** BPA 250 - BPA 7750  
**doc no:** 17-110-8014  
**issue:** 003

## 1.2 manufacturers details and support

### nano-purification solutions llc

**address:** 5509 david cox road  
charlotte, nc 28269  
usa  
**telephone:** 704.897.2182  
**fax:** 704.897.2183  
**internet:** www.n-psi.com  
**e-mail:** support@n-psi.com

### nano-purification solutions

**address:** 7 petrie street, unit 1  
st catharines, ontario  
l2p3j6  
canada  
**telephone:** 905.684.6266  
**internet:** www.n-psi.com  
**e-mail:** canadasupport@n-psi.com

### nano-purification solutions penn

**address:** 1437 route 66  
new bethlehem, pa 16242  
usa  
**telephone:** 724.297.3416  
**fax:** 724.297.5189  
**internet:** www.airtak.com  
**e-mail:** airtak@airtak.com

### nano-purification solutions ltd

**address:** dukesway  
team valley trading estate  
gateshead  
ne11 opz  
united kingdom  
**telephone:** +44 (0) 191 497 7700  
**internet:** www.n-psi.co.uk  
**e-mail:** enquiries@n-psi.co.uk

### annotations



**CAUTIONS:** indicate any situation or operation that may result in potential damage to the product, injury to the user, or render the product unsafe.



**NOTES:** highlight important sections of information where particular care and attention should be paid.





## 1.3 document introduction

This manual is meant for anyone who uses or works on the BPA blower purge desiccant air dryer, mainly the operators. The BPA blower purge desiccant air dryer and this manual are protected by copyright. Any reproduction of the same shall be liable for prosecution. All rights reserved by **nano-purification solutions**, particularly the rights of reproduction and distribution, as well as translation, including those relating to charges of copyright infringement. Any reproduction, processing, duplication, distribution of this document using electronic or mechanical means without the prior written authorization of **nano-purification solutions** is strictly prohibited. This document may have errors and is likely to be modified with respect to technical features.

## 1.4 warranty guidelines

All products are supplied with a 18 months manufacturer's warranty from the date of shipment from the factory or 12 months from date of installation/start up, whichever occurs first and installed and maintained in accordance with the manufacturers guidelines.

## 1.5 definition of safety symbols



Before attempting any intervention on the dryer, read carefully the instructions reported in this use and maintenance manual.



**General warning sign:** Risk of danger or possibility of damage to the machine. Read carefully the text related to this sign.



**Electrical hazard:** The relevant text outlines conditions which could result in injury. The related instructions must be strictly respected.



**Danger hazard:** Part or system under pressure.



**Danger hazard:** Component or system which during the operation can reach high temperature.



**Danger hazard:** It's absolutely forbidden to breathe the air treated with this apparatus.



**Danger hazard:** It's absolutely forbidden to use water to extinguish fire on the dryer or in the surrounding area.



**Danger hazard:** It's absolutely forbidden to operate the machine when the parts (under pressure or electric panels) are not in place or have been tampered with and changed.



**Danger hazard:** Machine level noise could be higher than 85 dBA. It is mandatory to install the machine in dedicated area where people are not normally present. The installer and/or the user is responsible for correct installation of the dryer, in order to prevent noise propagation to the near work environment. The installer and/or the user is also responsible for the safety signs affixing into installation site.



**Attention:** The user that intervenes to the machine must wear hearing protection to operate the dryer. Each employee must select proper PPD (Personal Protection Device) hearing protector (earmuffs, ear canal caps and earplugs) in order to prevent any uneasiness that could cause dangerous situation for him.



Maintenance and/or control operation to be very carefully performed by qualified personnel '.



Compressed air inlet connection point.



Compressed air outlet connection point.



# blower purge desiccant air dryer



Condensate drain connection point.



Operations which can be worked out by the operator of the machine, if qualified <sup>1</sup>.

NOTE : Text to be taken into account, but not involving safety precautions.

In designing this unit a lot of care has been devoted to the protection of the environment:



- Dryer and relevant packaging composed of recyclable materials.
- Energy saving design.

To ensure our commitment, the user should follow the ecological suggestions marked with this sign.

## 1.6 general warnings



Read the contents of this manual carefully before starting the units.



In order to make it easier to identify the units, it is important to always specify the technical features, especially the serial number, which are printed on the label on the outside of the dryer.



This service and maintenance manual describes the design, operation and the instructions for use and maintenance of the units manufactured by **na-no-purification solutions**.



The unit should not be operated, even for a short period of time, under conditions other than the ideal conditions.



**na-no-purification solutions** shall not be liable for any damage caused due to non-compliance with the instructions of this manual.



A part that does not guarantee safety should not be installed.



For any questions or any clarifications that may be required, our qualified **na-no-purification solutions** technicians are available to provide all the necessary information.



**WARNING:** This product can expose you to chemicals including lead, which is known to the State of California to cause cancer and/or birth defects or other reproductive harm. For more information, go to [www.P65Warnings.ca.gov](http://www.P65Warnings.ca.gov).



## 1.7 basic safety rules



Compressed air is a highly hazardous energy source. Never work on the dryer with parts under pressure. Never point the compressed air or the condensate drain jet towards anybody. The user is responsible for the installation of the dryer, which has to be executed on the basis of the instructions given in this user guide. Otherwise, the warranty will be voided and dangerous situations for the personnel and/or damages to the machine could occur.



Any change to the machine or to the relevant operating parameters, if not previously verified and authorized by the Manufacturer, may create the possibility of dangerous conditions it will void the warranty.



Don't use water to extinguish fire on the dryer or in the surrounding area.



Only qualified personnel can use and service electrically powered devices. Before attempting any maintenance action, the following conditions must be satisfied:

- Ensure that any part of the machine is under voltage and that it cannot be connected to the mains.
- Ensure that any part of the dryer is under pressure and that it cannot be connected to the compressed air system.

**nano-purification solutions shall not be held responsible for any possible damage caused, directly or indirectly, by persons or elements that are not non-compliant with these instructions.**

**Any assembling/removal carried out by THE USER, which is not provided for in this manual or not authorized by "nano-purification solutions", will be considered as an inappropriate operation, thereby damaging safety functions, and will lead to the cancellation of the warranty.**



# blower purge desiccant air dryer

## Essential safety rules



**Read this paragraph carefully and understand it**

**before operating or servicing this machine. The machine is connected to hazardous power circuits (electricity, pneumatic circuit, etc.) and should be used with great care.**

**This paragraph explains what needs to be understood in terms of safety before operating or servicing the machine. Non-compliance with these safety instructions risks causing injuries or fatal accidents, break-down of the machine, products or installations, or a serious incident.**

## Operator

- Prior training about the operation and maintenance of the device is a prerequisite for the use and maintenance of the dryer.
- Use and maintain the dryer with the consent of the system manager.
- It is very dangerous to let a person, with poor knowledge and poor understanding about the system and how the machine functions, use it and carry out maintenance operations in an improper or negligent manner.

## Before operating the dryer:

- Anyone using the dryer or carrying out its maintenance operations must read this manual carefully and understand its contents. Pay special attention to explanations with the heading "Danger", "Warning" and "Caution" and understand them thoroughly. Follow the instructions and avoid predictable hazards when you use the dryer or carry out its maintenance operations.
- Before operating or carrying out a maintenance operation, read and understand the safety instructions stated in this manual and the safety labels affixed, on the device, and follow the instructions. Failing the above, you risk suffering facial injuries or even fatal injuries. You also run the risk of the dryer, the products or the installation breaking down or causing a serious incident.
- Other safety instructions are provided in the other paragraphs.

## Warning labels (Warning)

- Warning labels are very important. Do not remove them deliberately.

- If they become dirty or illegible, or they get removed inadvertently or are lost, stick new labels in the place of the earlier ones.

## Danger warning

When you use the dryer or carry out a maintenance operation on it, pay attention to the three warning levels below. Understand their content and act accordingly. The warning messages appear on the warning labels placed on the dryer and given in the safety instructions paragraph of this manual.



**The "danger" messages provide warning about real dangers**

**and indicate the risks of fatal accident or serious injuries for the operator who does not strictly adhere to the safety instructions provided to avoid such dangers. They also provide warning about the risks of an accidental air leakage or fire due to improper handling.**

**The content of the messages is identical to the warning messages, except for indicating a higher level of severity. Danger labels generally have a red background.**



**The "warning" messages provide warning about real dangers and indicate the**

**risks of serious injuries or fatal accident for the operator who does not strictly adhere to the safety instructions provided to avoid such dangers. They also provide warning about the risks of an accidental air leakage or fire due to improper handling. Warning labels generally have an orange background.**



**The "caution" messages provide warning about real dangers and**

**indicate the risks of minor injuries for the operator, or damage to the system, products and installations, if they do not strictly adhere to the safety instructions provided to avoid such dangers. Caution labels generally have a yellow background.**





## 1.8 qualified operators

Only the professionals stated below are authorized to operate the unit after having received all the necessary instructions from this manual:

### **Specialized maintenance electrician**

The electrician should have a general knowledge about electrical appliances as well as specific experience working with control boxes and the electrical components of cooling units or similar equipment from the domain of industrial equipment.

The electrician is authorized to carry out only the specific operations stated in this manual by meticulously following the associated instructions.

### **Maintenance technician**

The maintenance technician should have a general experience working with mechanical elements and a specific experience with cooling units or similar equipment from the domain of industrial equipment.

The maintenance technician is authorized to carry out only the specific operations stated in this manual by meticulously following the associated instructions.

### **Transport operator**

The transport operator can carry out only the specific operations stated in this manual by meticulously following the associated instructions.

### **Staff allocated for the start-up and shut-down of the unit**

(Basic operator and engineer operator)

After having understood the information contained in this manual, the basic operator will be authorized to manually operate the unit at the level of the following functions: start-up, shut-down, display of alarms.

In this case, this operator can carry out only the specific operations stated in this manual by meticulously following the associated instructions.

### **Safety officer**

The safety officer is responsible for protection and the prevention of occupational risks as set forth in **OSHA Directive** (Safety in the workplace).

The safety officer shall make certain that all the persons who operate the unit have received all applicable instructions which are contained in this manual, including the initial installation and commissioning operation.



# blower purge desiccant air dryer

## 1.9 storage

### Keep away from:

- Direct sunshine, rain, wind and sand.
- Temperature: max. 140°F/min. 14°F
- Max. relative humidity: 90%

## 1.10 transport and handling



The carrier is always liable for any damage caused to the products entrusted to them during transport. Thus, before preparing the unit for its installation and commissioning, it is necessary to carry out a complete visual inspection in order to check that the packing cases are intact and the unit has no apparent damage. It is also important to verify that the units are the ones that have been ordered.



Do not leave the units in their packaging on premises that are exposed to direct sunlight because the ambient temperatures can effect the components and safety devices on the dryer.



Any damage or complaints must be reported to **nano-purification solutions** and declared to the carrier (or shipper) before the carrier leaves premises when product is delivered.



The equipment should be preferably lifted using a suitable crane or forklift. We do not recommend using hands. Handle with care. Heavy blows could cause irreparable damage. Even when packaged, keep the machine protected from severity of the weather.



If there is damage to one or more components, do not start the unit but inform **nano-purification solutions** about the problem to find a mutually agreeable course of action.



Preferably, remove the packaging at the actual place of installation.  
The unit should be handled with great care on the premises. Do not use any of its components as a grip. In order to avoid any damage, it is imperative that, during their handling, the units always remain in the position set for their operation.



## 1.11 proper use of the dryer

This dryer has been designed, manufactured and tested only to be used to separate the humidity normally contained in compressed air. Any other use has to be considered improper. The Manufacturer will not be responsible for any problem arising from improper use; the user will be in any case responsible for any resulting damage.

Moreover, the correct use requires the compliance with the installation conditions, in particular:

- Voltage and frequency of the mains
- Pressure, temperature and flow-rate of the incoming air
- Ambient temperature

This dryer is supplied tested and fully assembled. The only operation left to the user is the connection to the plant in compliance with the instructions given in the following chapters.



The purpose of the machine is the separation of water and eventual oil particles present in compressed air. The dried air cannot be used for respiration purposes or for operations leading to direct contact with foodstuff, unless subject to additional treatment.

## 1.12 instructions for the use of pressure equipment

To ensure the safe operation of pressure equipments, the user must conform strictly to the above directive and the following:

1. The equipment must only be operated within the temperature and pressure limits stated on the manufacturers name/data plate.
2. No welding is allowed on any of the pressure components.
3. The equipment must not be stored in poorly ventilated spaces, near a heat source or inflammable substances.
4. Vibration must be eliminated from the equipment to prevent fatigue failure.
5. An internal inspection must be carried out at 12 month intervals to check for pressure equipment corrosion.
6. Automatic condensate drains should be checked for operation every day to prevent a build up of condensate in the pressure equipment.
7. The maximum working pressure stated on the manufacturers data plate must not be exceeded.
8. All documentation supplied with the equipment (manual, declaration of conformity etc.) must be kept for future reference.



# blower purge desiccant air dryer

## 2.1 installation site

1. Install dryer in a vertical (upright) position. In systems where air usage fluctuates or there are sudden demands, protect dryer against air flow surges by providing sufficient piping between dryer and point of air use or by installing a receiver tank between dryer and point of air use. Allow enough space for future servicing of the unit.
2. Install by-pass piping with inlet, outlet, and by-pass valves to isolate dryer for performing routine maintenance without interruption of the plant air system. All equipment downstream of the air dryer should be rated for 400°F in the event hot air is emitted from the dryer. **(See warning at the bottom of Trouble Shooting - Page 26)**
3. Install a coalescing filter(s) with automatic drain upstream of the dryer inlet and a particulate filter(s) downstream of the dryer outlet. Bypass piping is recommended for both (all) filters.
4. Connect inlet air piping to dryer inlet (top of dryer) and outlet air piping to dryer outlet (bottom of dryer).



**CHECK ALL CONNECTIONS ON THE UNIT FOR TIGHTNESS.**

5. Connect 460 Volt, 60 Hertz, three phase electric power to terminals inside the 460 Volt control enclosure, in accordance with local and national codes. To prevent the Programmable Controller timing device, blower and heater from operating when the air supply is interrupted, it is recommended that provisions be made to shut off the dryer when the air compressor is not in use.



**CHECK ALL ELECTRICAL CONNECTIONS!**

6. Install remote piping of purge exhaust line if high temperature or humidity is objectionable. If remote piping is required, maintain piping temperature above freezing and allow for the draining of condensed moisture away from the dryer.

# blower purge desiccant air dryer



## 2.2 installation layout

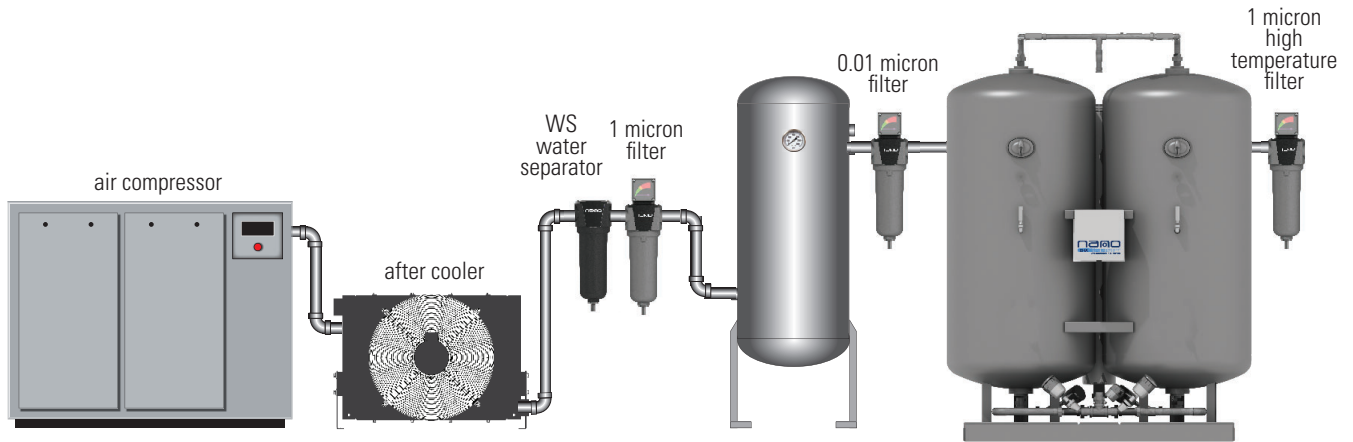

Installation is suggested when the compressed air treated from the dryer is only a part of the total flow rate of the compressor; or when the compressor operates at reduced load and the total consumption equals the compressor flow rate.



**Dryer is supplied with 0.01 micron filter on the inlet and a 1 micron high temperature filter on the outlet. It is recommended to install both water separator and 1 micron filter before the dryer, in order to extend the life of the inlet filter.**



# blower purge desiccant air dryer

## 2.3 dryer specifications

specifications	standard	optional
maximum particle size (ISO class) (*)	class 2 (1 micron)	class 1 (0.01 micron)
maximum water content (ISO class) (*)	class 2 (-40°F pdp)	-
min/design/max operating pressure range	80 psig / 100 psig / 150 psig	58 to 250 psig
min/design/max ambient temperature	38°F / 100°F / 120°F	-
min/design/max inlet temperature	38°F / 100°F / 120°F	-
power supply requirements	460 VAC / 60 Hz	

\*per ISO 8573.1:2010

## 2.4 correction factors

correction factor for inlet pressure									
psig	60	70	80	90	100	110	130	140	150
barg	4	5	6	6	7	8	9	10	10
F1 factor	0.65	0.74	0.83	0.91	1.00	1.04	1.12	1.16	1.20

correction factor for inlet temperature									
°F	70	80	90	100	105	110	115	120	
°C	21	27	32	38	41	43	46	49	
F2 factor	1.12	1.10	1.06	1.00	0.93	0.86	0.80	0.75	

### SIZING A DRYER

How to find the air flow capacity

$$\text{AIR FLOW CAPACITY} = \text{NOMINAL CAPACITY OF THE DRYER} \times \text{F1 FACTOR} \times \text{F2 FACTOR}$$

**Example:** A BPA 250 has a nominal capacity of 250 scfm.

What is the maximum allowable flow through the dryer at following operating conditions:

Air Inlet Pressure: 110 psig (8 barg) From table for pressure correction F1=1.04

Air Inlet temperature: 105°F (41°C) From table for temperature correction F2=0.93

$$\text{AIR FLOW CAPACITY} = 250 \text{ scfm} \times 1.04 \times 0.93$$

Air Flow Capacity= 241.8 scfm

This is the maximum air flow rate that the dryer can accept under those operating conditions.



## 2.5 operation

### SET UP

1. Remove fill plug. Fill tanks slowly with specified desiccant. Replace fill plug.
2. Remove muffler to prevent clogging from desiccant dust.



**Note: Always wear ear protection when muffler is removed.**

3. With dryer by-pass valve open, **slowly** open the inlet valve to the dryer and allow the unit to pressurize. When the pressure gauges indicate that the dryer is at full line pressure, open dryer outlet valve and close the by-pass valve. The filters should be placed on-line using a similar procedure.
4. To start up the dryer, turn the supply power (460 VAC) on. Turn the selector switch on the front of the cabinet so the POWER ON selector is on. The display panel will come on. After a short time, one tower will depressurize and start to regenerate, the other tower will be drying air at full line pressure. After about 4 hours, the low pressure tower will pressurize and the towers will switch functions.
5. Adjust the purge flow control valve to the proper pressure setting indicated in the **setting the purge pressure (Page 23)** section while the dryer is in the last half of the regeneration cycle or cool down period.
6. Re-install the muffler after one complete cycle.

### SHUT DOWN

1. Turn dryer off.
2. Allow towers to depressurize to atmospheric pressure.
3. Allow the dryer to cool completely before performing any maintenance.



# blower purge desiccant air dryer

## 2.6 recommendations for optimal performance

1. Do not exceed rated design flow.
2. Make sure dryer is turned on when air is passed through the unit. Tower switching is vital to the successful drying of air.
3. Change pre-filter and after-filter elements regularly. The coalescing pre-filter, when operating properly, will remove contaminants such as oil and liquid water as well as abrasive solids that could reduce the effectiveness of the dryer. The particulate after-filter will prevent desiccant particles from migrating downstream and possibly damaging equipment.
4. Never weld to vessel framework. This may cause damage to the Programmable Logic Controller which controls dryer operation.
5. Check and clean the muffler often during initial operation. Desiccant dust is especially heavy after shipment and tower filling. Allow the dryer to cycle several times without the muffler.



**REMEMBER TO WEAR HEARING PROTECTION.**

### SAFETY

1. Do not repair or replace any part of the dryer while the unit is under pressure.
2. Do not repair or rewire electrical components of the dryer while power is supplied to the unit.
3. Avoid touching high temperature piping and the desiccant towers while the dryer is operating.



**CHECK ALL ELECTRICAL CONNECTIONS!**





## 2.7 maintenance

1. Change pre-filter and after-filter elements regularly!
2. Periodically check that the dryer is cycling properly. Watch for each tower to alternate between line and atmospheric pressure. The entire cycle will take about 8 hours.
3. Approximately once a year, shut unit down and inspect all valves. (Based on an 8 hour work day).
4. Approximately once a year, check the desiccant bed for oil contamination and/or losses.
5. Approximately once a year, inspect and clean purge muffler(s). If signs of oil are present, desiccant may be contaminated.
6. Periodically verify that insulation is in good condition and repair or replace if necessary.
7. Inspect and change blower intake filter every 3 to 6 months or 1000 to 3000 run hours.
8. Inspect and change the blower drive belt (if equipped with one) every 12 to 36 months or 3000 to 12000 run hours.
9. Inspect and change idler pulley for the blower (if equipped with one) every 8 to 36 months or 3000 to 12000 run hours.

### REPLACING DESICCANT

1. Open by-pass valve. Close dryer outlet valve and dryer inlet valve.
2. Turn dryer off.
3. Allow towers to depressurize to atmospheric pressure.
4. Allow the dryer to cool completely.
3. Loosen plug at bottom of tower. Allow desiccant to drain, then replace plug. Loosen plug at top of tower. Fill with fresh desiccant, then replace plug. (For molecular sieve use: 1/3 activated alumina, 1/3 molecular sieve, 1/3 activated alumina)
4. Desiccant dust may be unusually heavy after changing the desiccant. To remove this dust from the dryer, allow the dryer to cycle several times **without** the purge muffler.



**Remember to wear hearing protection during this procedure.**

5. A couple of weeks after filling the dryer with desiccants, shut the unit down and check desiccant level. Top off with fresh desiccant if necessary.
6. Should a problem arise, consult **trouble shooting (Page 26)**.



# blower purge desiccant air dryer

**IMPORTANT: BPA BLOWER PURGE DESICCANT AIR DRYERS ARE DESIGNED TO USE A SPECIFIC DESICCANT. WHEN REPLACING THE DESICCANT, ALWAYS USE DESICCANT OF THE SAME SIZE AND TYPE AS THAT WHICH WAS SUPPLIED WITH YOUR DRYER. FOR MORE INFORMATION, PLEASE CONSULT THE FACTORY.**

## **CHANGING FILTER ELEMENTS**

1. Take the dryer off-line following the steps detailed in the section entitled **operating the three-valve bypass (Page 21)**. Be sure to bleed off all air pressure from the dryer and filters before performing any maintenance.
2. Remove any external drain valve from the filter housing.
3. Remove the bowl from the head of the filter by turning bowl in a counter clockwise direction.
4. Remove the dirty filter element by removing the threaded endcap at the bottom of the filter. Dispose of dirty elements properly.
5. Guide new element over the center rod and replace the threaded endcap, taking care to ensure that the new element is seated properly. Do not overtighten the endcap.
6. Replace the filter housing and drain valve. Check all connections for tightness to prevent air leaks before bringing the dryer back online. See section entitled **operating the three-valve bypass (Page 21)** for instructions on bringing the dryer on-line.

# blower purge desiccant air dryer



## 3.1 BPA operating sequence

The heater control circuitry monitors the heater sheath temperature to a safety set point. If the core temperature of the heater reaches the set point the PLC will disengage the Heater Safety Contactor and shut down the heater and keep the temperature from running away. An alarm will be generated. If the alarm is set off the heater circuit should be inspected before clearing the alarm. Be sure to check the heater contactor to make sure the tips are not jammed or welded together.

The PLC also monitors the temperature of the purge air with a thermocouple located where the heater is connected to the bottom piping. The PLC will turn the heater off when the temperature reaches the set point typically 400F°. When purge temperature reaches the lower limit, the heater will be turned back on till the temperature reaches the set point again. It will cycle between the upper and lower set points till the end of the heating cycle.

If the heater temperature does not reach low low limit set point the dryer will switch into a heatless cycle and the towers will switch every five minutes and the purge bypass valve will open to allow more purge air so the towers can be regenerated properly. The dryer will stay in heatless mode till it is reset. The heating circuit should be inspected before resetting the unit.

A Visual Moisture Indicator (VMI) is located near the discharge of the dryer. It senses the dew point of the air going downstream of the dryer. The VMI will be green if the dew point is below -20°F and turn yellow when the dew point is above approximate -20°F.

If the unit is equipped with the Energy Saver option, the dryer will have a dew point probe instead of the VMI. The dew point probe will display the current dew point on the touchscreen display.

With an Energy Saver option, at the end of the drying cycle it will compare the outgoing dew point reading to the set point. If the dew point is better then the set point, the program will hold the online tower from switching until the dew point is no longer lower than the set point. It will hold the tower up to sixteen (16) hours. The set point can be change in the Set-Up Screen on the touchscreen. The set point should be -40°F from the factory. If the plant can work at a dew point higher than that, the set point can be change to a higher point. With a dew point of -35°F or higher an energy savings can be realized.

It may be necessary to periodically remove the probe for calibration or repairs. To do this without disrupting the normal operation of the dryer, a few steps need to be followed.

First go to the Set-Up screen and change the dew point control button to off.

Next close the 3/8" ball valve ahead of the dew point probe.

Disconnect the wires from the probe and unthread the probe from the tee. You may want to install a pipe plug in the tee and close the needle valve if the ball valve is not trusted.

To reinstall the probe, thread the probe into the tee, make sure it is tight. Connect the wires to the probe. Open the needle valve slightly, then open the ball valve slowly. There should be a small about of air coming out of the brass muffler, the probe needs a constant flow of dry process air across it to work properly. The dew point reading should be displayed on the touchscreen. If the probe is not kept in a small amount of desiccant it can absorb some water vapor form the ambient air. The probe will dry out quickly with the dry air moving across it. The last step would be to turn the dew point control button back ON, on the Set-Up Screen.



## blower purge desiccant air dryer

- If the reading is between  $-112^{\circ}\text{F}$  and  $-157^{\circ}\text{F}$  there is a problem with the probe. Most likely there is a open cable connection or an incorrect connection.
- Each tower will have a pressure transducer to monitor the pressure in both towers as it cycles through the program. The online tower should be at line pressure while drying process air. The offline tower should be at or near zero while it is in heating and stripping cycles. It will go back to line pressure when it is done with the repressurization cycle. If the PLC does not see the proper pressure at the proper time in the cycle it will set off an alarm.



## 3.2 operating the three-valve bypass

1. All dryers can be equipped with a 3-valve bypass system from the factory for ease in performing routine maintenance such as changing filter elements and desiccant. If your dryer does not have a 3-valve bypass from the factory, it is recommended that you install the bypass valves in your lines when the dryer is put in service. It should be like the one depicted in Figure 1.0.
2. During normal operation, valves 1 & 3 will be open and valve 2 will be closed, allowing air to flow through the filters and dryer.
3. To perform routine maintenance, operate the valves in 3-2-1 order to allow air to flow directly from the inlet connection to the outlet connection without passing through the dryer (close valve 3, open valve 2 and close valve 1). Remember to bleed the air pressure from the dryer and filters before performing any service. See Sections entitled **maintenance (Page 17)**, **CHANGING FILTER ELEMENTS (Page 18)**, or **REPLACING DESICCANT (Page 17)** for specific instructions.
4. When bringing the dryer back on-line after maintenance, operate the valves in 1-2-3 order to prevent back flow to the dryer and filters. (Open valve 1, close valve 2, open valve 3.)

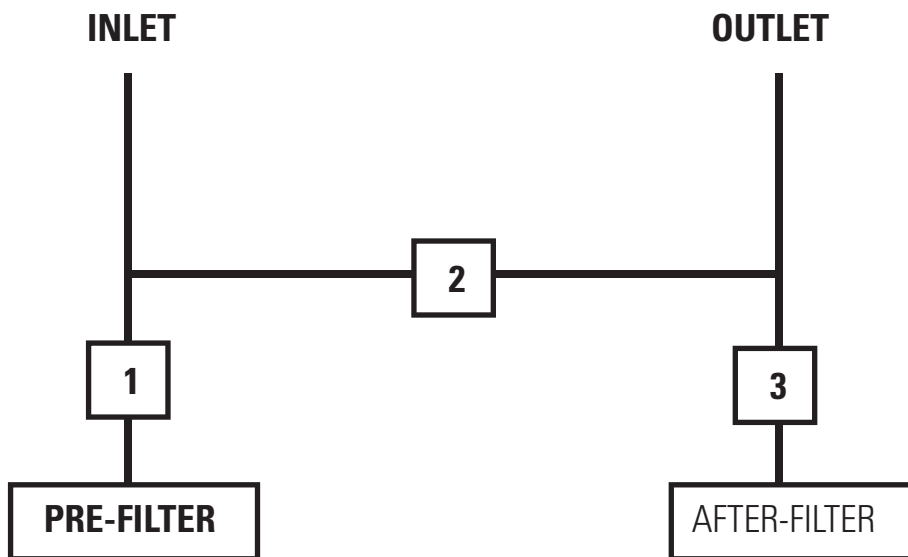

Figure 1.0 - Typical BPA F2-3V Three-Valve Bypass



# blower purge desiccant air dryer

## OPERATING PRINCIPLE

The BPA blower purge desiccant air dryers consists of two tanks filled with Activated Alumina. At any given time, one tower will be drying the compressed air while the other tower is regenerating the saturated desiccant beads (Activated Alumina). A small portion of the dry air (termed Purge Air) is used for the regeneration of the saturated desiccant, expanding it to near atmospheric pressure and heating it in an external electric heater and blower. The condensate that is stripped from the desiccant bed is purged into the atmosphere through the purge exhaust valve and the purge exhaust mufflers.

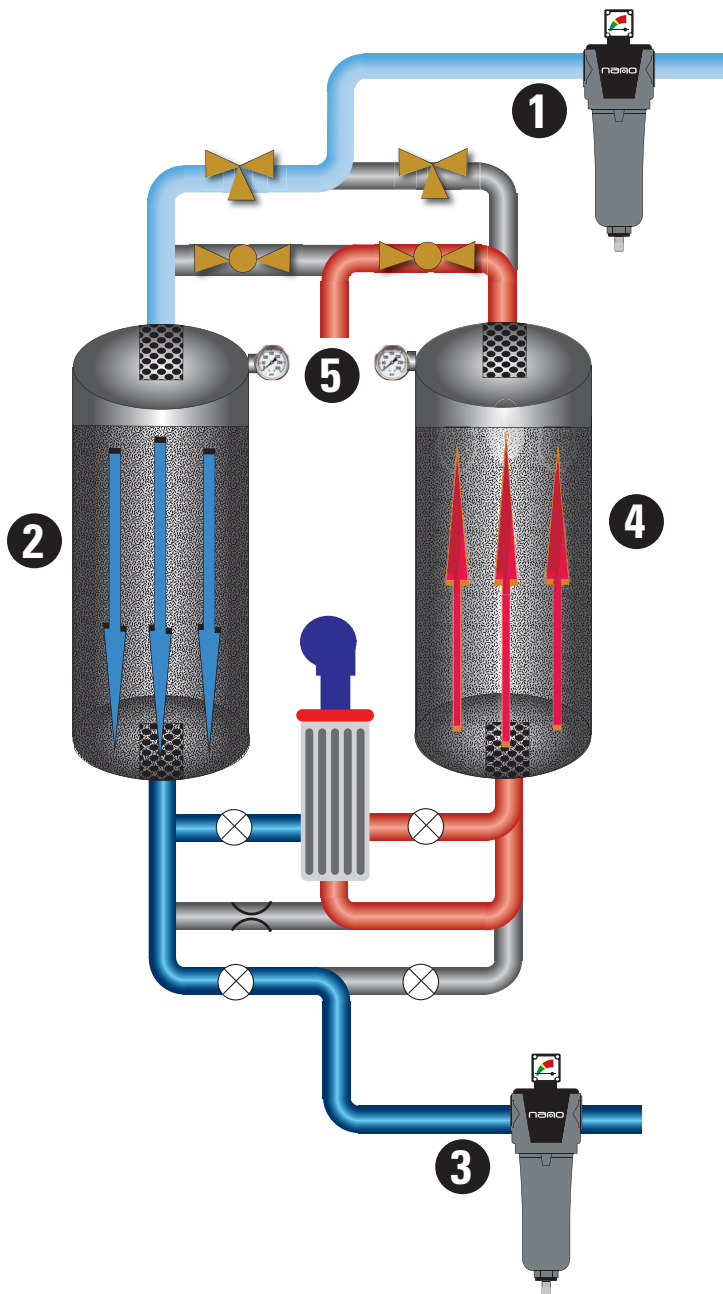

- 1** Wet, contaminated air passes through coalescing pre-filter to remove particulate and liquid down to 0.01 micron.
- 2** Air passes through desiccant bed where moisture vapor is adsorbed.
- 3** Dry air passes through 1 micron after-filter which retains any dust particles.
- 4** Simultaneously, a small amount of dry "purge air" is counter-flowed being directed through opposite tower along with external electric heater and blower removing moisture and regenerating the desiccant bed.
- 5** Purge air exhaust.

"Purge air" is approximately 2%.

# blower purge desiccant air dryer



## 3.3 setting the purge pressure

The Blower Purge Regenerative Air Dryers use a combination of heated ambient air and dry compressed air to purge moisture from the off-line tower. The dryer operates on an eight-hour cycle. Each tower dries for four (4) hours and purges for four (4) hours.

Heated ambient air is used for the first three hours of the purge cycle. For 53 minutes of the remaining hour, dry compressed air from the on-line tower is used for purge. This is done for two reasons; 1) As a final purge to remove any remaining moisture from the off-line tower. 2) To cool the desiccant bed before the tower is put back on-line.

It is necessary to adjust the purge pressure of your dryer during the stripping portion of the purge cycle based on the size of the dryer. This will enable the dryer to produce a -40°F pressure dew point while operating under normal conditions.

To set the purge pressure, find the purge pressure needed from the Blower Heated Technical Specs matrix. Use the Model column to find your size of dryer, then move across to the PSI column to get what pressure to set the Purge Pressure Valve to.

### BLOWER HEATED TECHNICAL SPECS

model	capacity	cfm	orifice (color)	orifice (size)	desiccant per tower (lbs)	in/out connection
<b>BPA 250</b>	250	20	tan	5/32"	200	1 ½" NPT
<b>BPA 350</b>	350	28	green	3/16"	275	1 ½" NPT
<b>BPA 500</b>	500	40	pink	7/32"	375	2" NPT
<b>BPA 700</b>	700	56	red	1/4"	525	2" NPT
<b>BPA 850</b>	850	68	dark grey	9/32"	650	2" NPT
<b>BPA 1000</b>	1000	80	dark grey	9/32"	750	3" Flg
<b>BPA 1350</b>	1350	108	yellow	3/8"	1025	3" Flg
<b>BPA 1700</b>	1700	136	yellow	3/8"	1275	3" Flg
<b>BPA 2100</b>	2100	168	silver	7/16"	1575	4" Flg
<b>BPA 2400</b>	2400	192	silver	7/16"	1800	4" Flg
<b>BPA 3100</b>	3100	248	white	1/2"	2325	4" Flg
<b>BPA 3800</b>	3800	304	dark blue	9/16"	2850	6" Flg
<b>BPA 4300</b>	4300	344	black	5/8"	3225	6" Flg
<b>BPA 5000</b>	5000	400	black	5/8"	3750	6" Flg
<b>BPA 6250</b>	6250	500	orange	11/16"	4700	8" Flg

Next go to the Purge Pressure Valve, typically under the control box and between the towers, but on larger sizes it could be in the back of the dryer. During the stripping cycle, look at the Purge Pressure Gauge to see what the purge is at. Turn the Purge Pressure Valve to set the right pressure on the gauge. The purge is set for your dryer.



# blower purge desiccant air dryer

## 3.4 operation of display screen

- Turn the Power On selector switch on, the screen will display a flow diagram of the unit, after a few seconds of the screen initializing the configuration.

### FLOW DIAGRAM SCREEN

- The flow diagram screen will show the state of the towers, valves, and mufflers. The valves will be green in color when they are open, and red when they are closed.
- The tanks will be green when it is drying process air for the plant use. It will turn red when it is being regenerated (off-line). It will be either Heating, Stripping or Pressurizing.
- The tank will turn yellow when it is in stand by mode. Stand By mode is when the tank has been regenerated and pressurized, but the dew point is still good from the on-line tank. The tank will stay in this mode till the dew point falls outside the set point or 16 hours have passed. The dryer must be equipped with the Energy Saver option for this to occur.
- The mufflers will be red when the vessel is on-line, pressurizing, or in stand by. When air is passing through the muffler it will turn green.
- The heater and blower will turn green when they are running and red when they are turned off.
- On each vessel, the state that it is in will be displayed on it, along with the time it has been in that state. (DRY, HEAT, STRIP, PRESSURIZE, STANDBY)
- The dew point and the dew point set point are displayed at the bottom of the screen.
- The heater temperature and heater set point are display next to the heater on the display.
- The blue button in the upper left corner will transfer the display to the next screen.
- The ALARM RESET button will appear at the top center of the screen when an alarm condition has occurred. By pressing it, the screen will change to the Alarm screen.
- The MANUAL STEP button will appear when the dryer is placed in the manual mode for maintenance purposes. This button will advance the dryer one step each time it is pressed. A blue dialog box will appear and identify the step that the dryer is in.
- The SYSTEM SETUP button will transfer the display the system set up screen. A password will be needed to access this screen.
- The SCREEN SAVER button will cause the screen to go blank. The screen saver can be turn off by touching anywhere on the screen.

### ALARM SCREEN

- The alarm screen will display any alarms that have occurred.
- The ALARM RESET button will clear any alarm shown, if the problem has been rectified.
- The ALARM HISTORY button shows what alarms have occurred, the last one will be number one on the list. The detail button will show when it happened and when it was cleared. The alarm count button will show how many of each alarm has occurred. The clear all button will erase the history log.
- The TS GUIDE button will show the most likely cause of the alarm and where to start the troubleshooting process.



# blower purge desiccant air dryer



## DEW POINT TREND SCREEN

- This screen is a trend of the dew point readings. It will display a reading every 15 minutes on the graph. The graph will display 96 points and by using the scroll buttons at the top of the graph, it can move backwards in time to through 11052 data points (12 days)
- The current reading is displayed on the graph as well.
- The dryer will have to have the Energy Saver option to be able to read the dew point

## HEATER TEMPERATURE TREND SCREEN

- The graph tracks the temperature of the heater. It displays a data point every 15 minutes and the graph displays 96 points. Using the scroll buttons at the top of the graph, the trend can move backwards to show 11052 data points (12 days).
- The current heater temperature is displayed on the graph.

## SYSTEM SET UP SCREEN

- A password is needed to enter this screen. The password for the screen is "777".
- The MODE button will change the operation of the dryer. Auto mode allows the PLC to run the dryer. The system will operate automatically. When the dryer is in Manual mode, the dryer will only change states when the MANUAL STEP button is pushed on the Flow Dia. Screen. It will stay in this mode for one hour then switch to AUTO mode, so the unit can not be left in Manual mode by mistake.
- The DUE POINT CONTROL button will disable the option when it is pushed. It must be pressed again to enable the function.
- The FAIL TO SWITCH button will disable the option when it is pushed. It must be pressed again to enable the function.
- The HEATER TEMP indicator shows the heater temperature set point. The increment and decrement arrows can be used to adjust the set point up or down. It will move in 10-degree increments.
- The FACTORY DEFAULT button will return all variables back to their original values. The dew point set point will be -40°F, the heater temperature set point will be 500°F, the dryer will be in Auto mode with the DEW POINT CONTROL and Fail to Switch options activated.
- DRYER TYPE button can change the program from an External Heated Dryer and a Blower Purge Dryer.
- FILTER psid button is if differential pressure transducers are used.
- HEATLESS MODE button can put the unit in heatless mode if the heater or blower were removed from service. The unit would go in to a 10-minute cycle and increase the purge amount to regenerate the off-line tower. Press the button again to take it out of heatless mode. This should be done when the towers are ready to switch.
- TECH PAGE 1,2, and 3 goes to a TECH PAGE where program parameters can be entered. These pages are password protected since making changes to these parameters can seriously affect the operation and quality of the air the dryer produces.

## TECH PAGE 1

- The BLOWER REMAIN ON TIME display and adjustment arrows are for setting the time the blower remains on when the heater is turned off. This allows the blower to run for a set amount of time to cool the heater down after it is done with the heating cycle.
- The HTR SHEATH OVERTEMP SP is where the set point for the heater sheath or tube is set. The set point is set at the factory and protects the heater from running away and melting down. The arrow buttons can adjust the set point.



# blower purge desiccant air dryer

## 4.1 trouble shooting

problem	cause	solution
Poor dew point performance	Flow exceeds rated capacity	Reduce flow or consult factory if increased flow volume is needed
	Low inlet pressure	Check and replace pre-filter element if necessary
	Excessive water	Check upstream separator, pre-filter and drain
	Desiccant contamination	Replace desiccant and filter elements
	High inlet temperature, above 110°F	Check upstream after cooler
	High or low ambient conditions	Change dryer location to correct condition
	Heat malfunction	See Heater Malfunction section
Excessive pressure drop across dryer	Excessive inlet flow	Reduce flow or consult factory if increased flow volume is needed
	Low inlet pressure	Check pre-filter and replace element if necessary
	Switching valve failure	Check for proper valve operation. If valve hangs up, check pilot air filter and replace element if necessary. Inspect valve, solenoid and actuator and replace if necessary
Switch-over failure	Electric power loss	Turn dryer off. Check power to unit. Check all connections to process controller
	Switching valve failure	Check for proper valve operation. If valve hangs up, check pilot air filter and replace element if necessary. Inspect valve, solenoid and actuator and replace if necessary
Pressurization failure	Purge regeneration valve orifice clogged	Clean or replace
	Failure of check valve	Clean or replace check valve if necessary
	Purge valve failure	Check for proper valve operation. If valve hangs up, check pilot air filter and replace element if necessary. Inspect valve, solenoid and actuator and replace if necessary
Regeneration failure	Failure of check valve	Clean or replace
	Purge valve failure	Check for proper valve operation. If valve hangs up, check pilot air filter and replace element if necessary. Inspect valve, solenoid and actuator and replace if necessary
	Purge exhaust muffler clogged	Clean or replace
	Blower malfunction	See Blower Malfunction section

# blower purge desiccant air dryer



problem	cause	solution
Back-pressure build-up in tower being purged.	Purge exhaust muffler clogged	Clean or replace
	Failure of check valve	Clean or replace
Heater malfunction	Excessive heat	Verify regeneration flow. Verify operation of blower. Verify that cooling cycle is function properly (see Dryer Operating Sequence).. Verify heater temperature reading. Replace thermocouple if necessary
	No power	Check power supply and fuses
	Blower motor failure	Repair or replace motor
Blower malfunction	Contactors not operating	Check wiring and power supply to contactor
	Motor wire loose or disconnected	Connect wire(s) as shown in Wiring Diagram
	Overload tripped. (models BPA 250 - BPA 1700 only)	Check blower motor. Check purge muffler and intake filter for flow restrictions



**WARNING:** If the manual mode is used for trouble shooting, the dryer may be moved into the next half of the cycle, allowing the towers to switch without sufficient cool down, hot air up to 400°F may be sent downstream. Caution should be taken to protect personnel and equipment from these elevated temperatures.



# blower purge desiccant air dryer

## 4.2 arrangement drawings

**BPA 250 to BPA 7750**

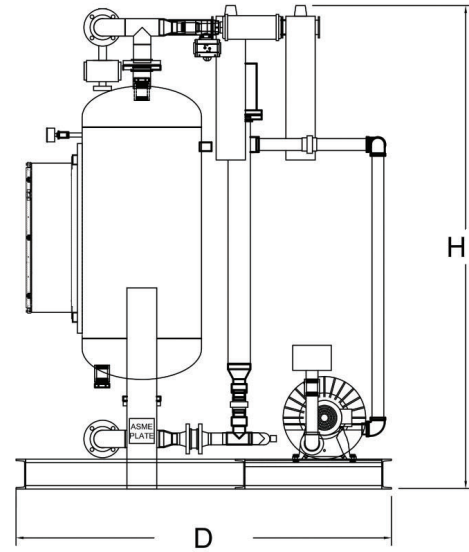
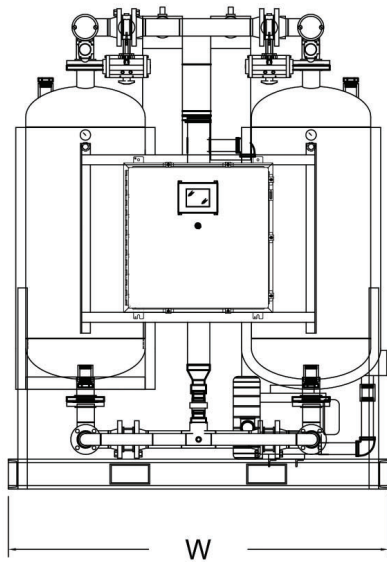

model	dimensions		
	W	D	H
	in	in	in
<b>BPA 250</b>	61	40	87
<b>BPA 350</b>	63	43	88
<b>BPA 500</b>	70	51	89
<b>BPA 700</b>	71	51	89
<b>BPA 850</b>	82	55	95
<b>BPA 1000</b>	84	57	110
<b>BPA 1350</b>	109	80	113
<b>BPA 1700</b>	140	81	112
<b>BPA 2100</b>	140	76	112
<b>BPA 2400</b>	148	84	112

# blower purge desiccant air dryer



## BPA 250 to BPA 77750 (continued)

model	dimensions		
	W	D	H
	in	in	in
<b>BPA 3100</b>	155	86	112
<b>BPA 3800</b>	165	101	112
<b>BPA 4300</b>	175	106	112
<b>BPA 5000</b>	185	109	112
<b>BPA 6250</b>	205	112	112
<b>BPA 7750</b>	230	115	112



# blower purge desiccant air dryer

## 4.3 electrical drawings

### blower with one circuit heater

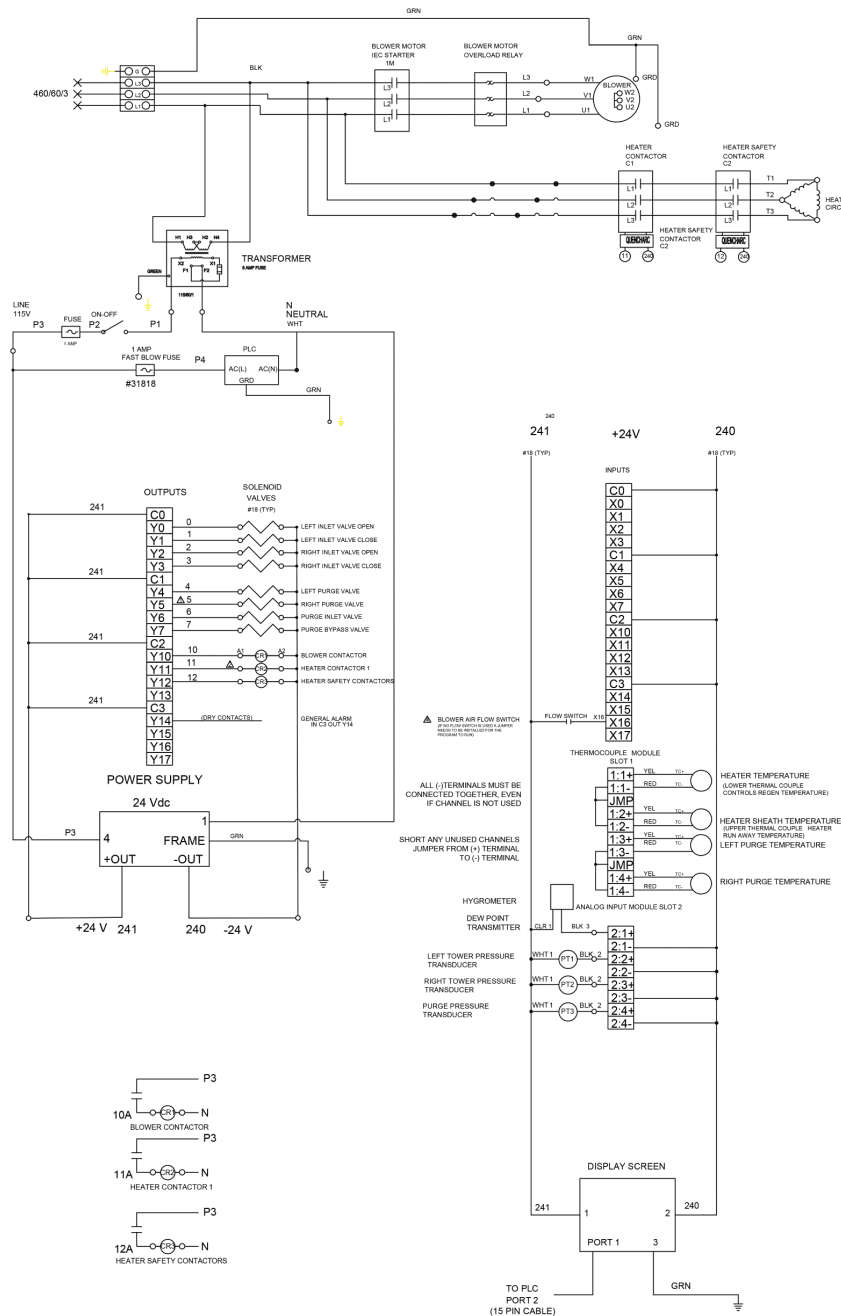

# blower purge desiccant air dryer



## blower with two circuit heater

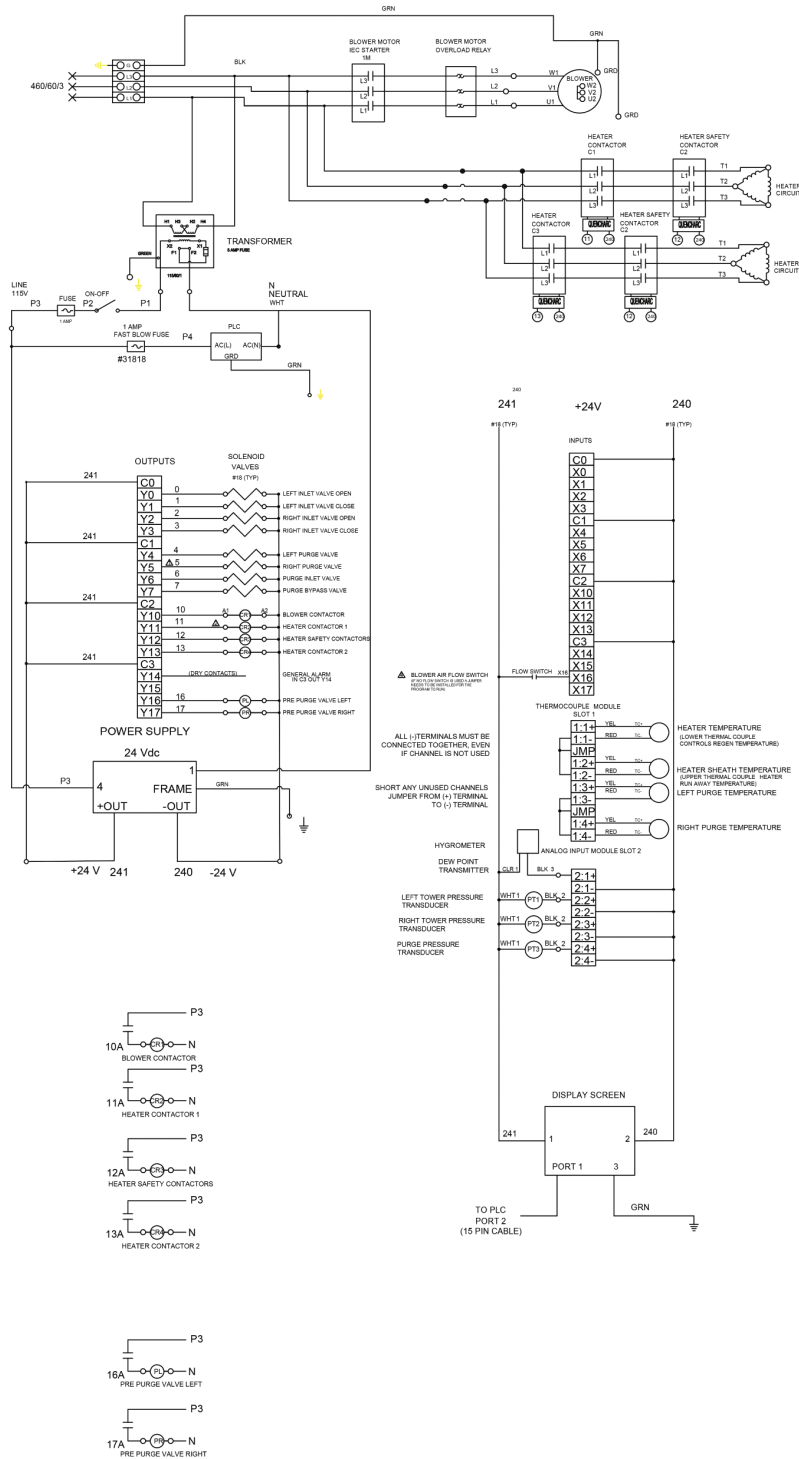



# blower purge desiccant air dryer

## blower with three circuit heater

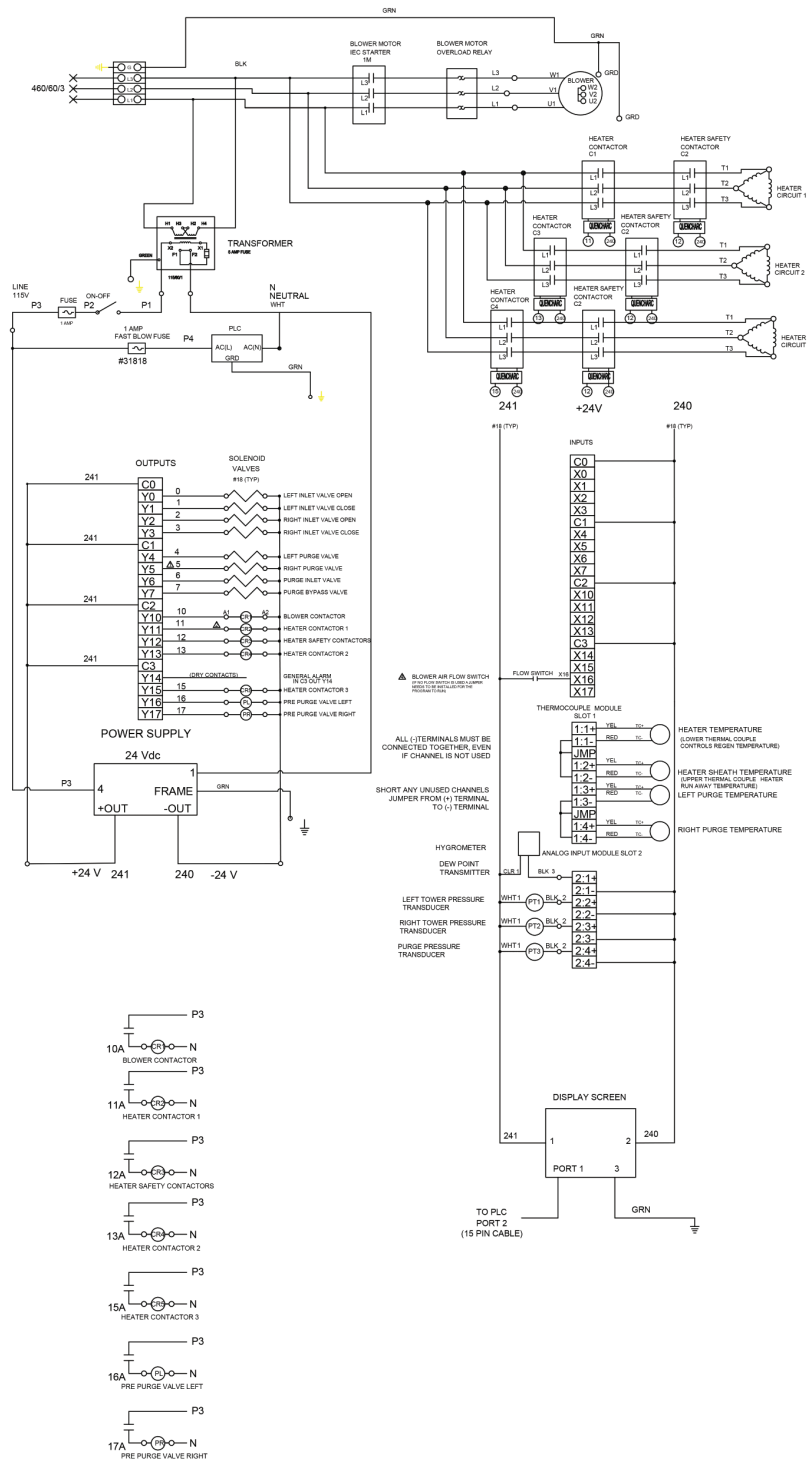



# blower purge desiccant air dryer



## 4.4 P & ID

BPA 250 to BPA 7750

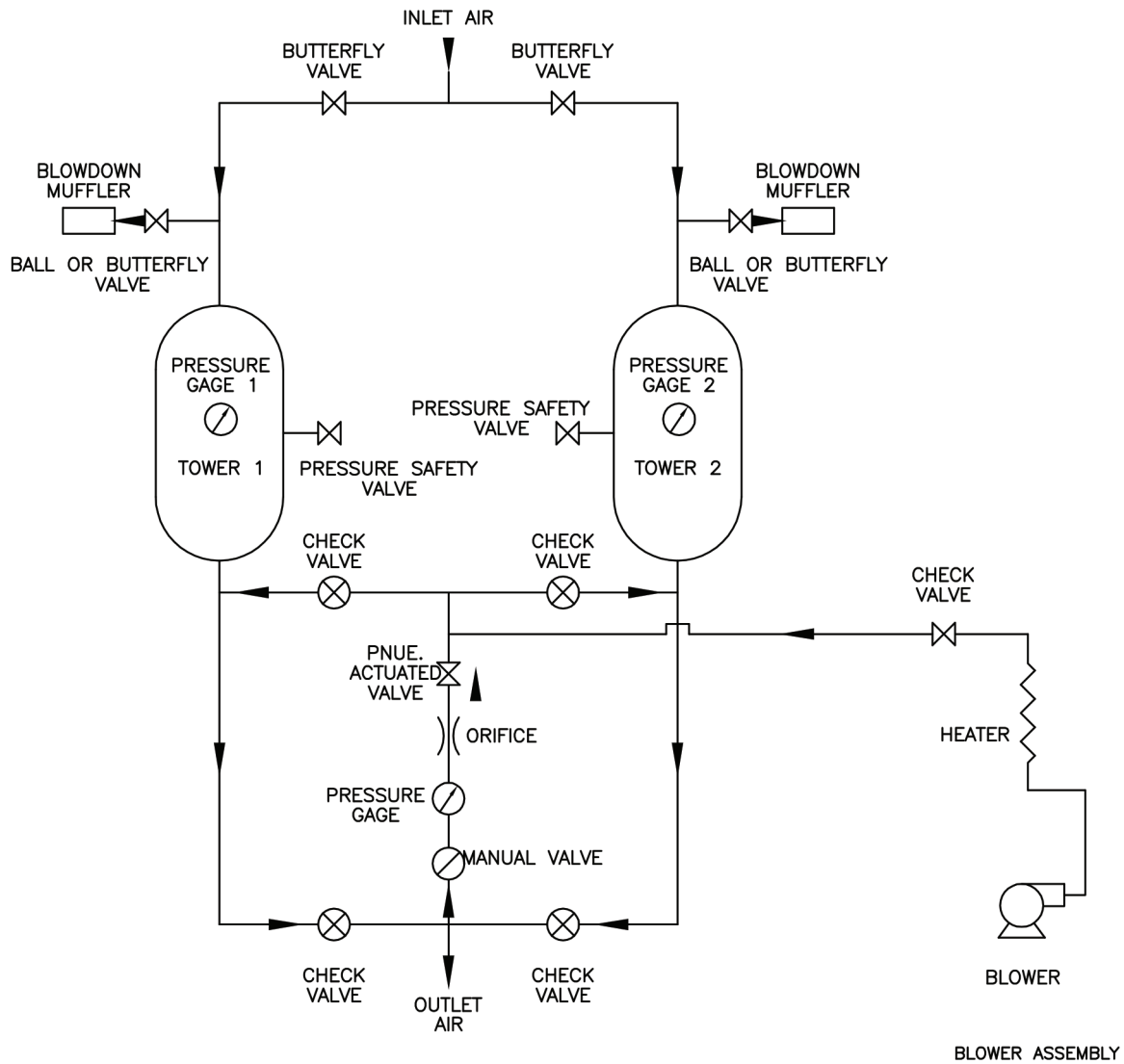



# blower purge desiccant air dryer

## 4.5 appendixes

reference	power supply	heater	blower	inlet & outlet <sup>(1)</sup>	max working pressure	dimensions			approx. weight <sup>(2)</sup>
model		kW	hp	NPT(F)/Flg	(psi)	W (in)	D (in)	H (in)	lbs
<b>BPA 250</b>	460 VAC/60 Hz	4.5	1.5	1 ½"	150	61	40	87	1200
<b>BPA 350</b>	460 VAC/60 Hz	6	3	2"	150	63	43	88	1850
<b>BPA 500</b>	460 VAC/60 Hz	10	2.75	2"	150	70	51	89	2750
<b>BPA 700</b>	460 VAC/60 Hz	15	3.42	2"	150	71	51	89	3650
<b>BPA 850</b>	460 VAC/60 Hz	18	4.6	2"	150	82	55	95	4200
<b>BPA 1000</b>	460 VAC/60 Hz	18	6.16	3"	150	84	57	110	4800
<b>BPA 1350</b>	460 VAC/60 Hz	25	10	3"	150	109	80	113	6300
<b>BPA 1700</b>	460 VAC/60 Hz	30	15	4"	150	140	81	112	7000
<b>BPA 2100</b>	460 VAC/60 Hz	38	15	4"	150	140	76	112	9000
<b>BPA 2400</b>	460 VAC/60 Hz	50	15	4"	150	148	84	112	11000
<b>BPA 3100</b>	460 VAC/60 Hz	60	15	6"	150	155	86	112	13700
<b>BPA 3800</b>	460 VAC/60 Hz	67	15	6"	150	165	101	112	17800
<b>BPA 4300</b>	460 VAC/60 Hz	75	15	6"	150	175	106	112	20500
<b>BPA 5000</b>	460 VAC/60 Hz	100	15	6"	150	185	109	112	22300
<b>BPA 6250</b>	460 VAC/60 Hz	125	30	8"	150	205	112	112	25500
<b>BPA 7750</b>	460 VAC/60 Hz	CF	CF	8"	150	230	115	112	CF

(1) 3" and below are NPT(F) threaded. 4" and above are flanged. All units with 3" piping and above will be ANSI welded pipe

(2) approx. weight for all models does not include desiccant installed









nano

---

**Experience. Customer. Service.**



**nano-purification solutions**

charlotte, north carolina

tel: 704.897.2182

support@n-psi.com

www.n-psi.com



**nano-purification solutions**

new bethlehem, pennsylvania

tel: 724.297.3416

airtak@airtak.com

www.airtak.com



**nano-purification solutions**

st. catharines, ontario, canada

tel: 905.684.6266

support@n-psi.com

www.n-psi.com



**nano-purification solutions**

gateshead, united kingdom

tel: +44 (0) 191.497.7700

sales@n-psi.co.uk

www.n-psi.co.uk



**nano-purification solutions**

erkelenz, germany

tel: +49 (0) 2151.482.8218

sales@n-psi.de

www.n-psi.de