

NANO

Condensate treatment



**NED 4L, NED 6LC, NED 8LC, NED 16LC, NED 40LC, NED 160LC,
NED 350L**

nano

Instruction book

NANO

Condensate treatment

NED 4L, NED 6LC, NED 8LC, NED 16LC, NED 40LC,
NED 160LC, NED 350L

Instruction book

Original instructions

Copyright notice

Any unauthorized use or copying of the contents or any part thereof is prohibited.

This applies in particular to trademarks, model denominations, part numbers and drawings.

This instruction book is valid for CE, non-CE as well as UKCA labelled machines. It meets the requirements for instructions specified by the applicable European directives or UK statutory instruments as identified in the Declaration of Conformity.

January 2023

No. 2920 7213 30

www.n-psi.com

The logo for NANO, consisting of the word "nano" in a stylized, lowercase, blue font. The letters are bold and have a modern, sans-serif appearance.

Table of contents

1	Safety precautions.....	4
1.1	SAFETY ICONS.....	4
1.2	GENERAL SAFETY PRECAUTIONS.....	4
1.3	SAFETY PRECAUTIONS DURING INSTALLATION.....	5
1.4	SAFETY PRECAUTIONS DURING OPERATION.....	6
1.5	SAFETY PRECAUTIONS DURING MAINTENANCE OR REPAIR.....	6
1.6	DISMANTLING AND DISPOSAL.....	7
2	General description.....	9
2.1	FUNCTIONAL DESCRIPTION.....	9
3	Control panel.....	11
3.1	DESCRIPTION.....	11
3.2	OPERATION LOGIC.....	12
3.3	FLOW CHART.....	16
4	Installation.....	18
4.1	INSTALLATION PROPOSAL.....	18
4.2	DIMENSION DRAWINGS.....	21
4.3	ELECTRICAL CONNECTIONS.....	27
5	Operating instructions.....	31
5.1	COMMISSIONING.....	31
5.2	SHUTTING DOWN.....	31

6	Maintenance.....	32
6.1	MAINTENANCE ACTIVITIES.....	32
6.2	SERVICE KITS.....	34
7	Problem solving.....	35
7.1	GENERAL CAUSES.....	35
7.2	FAULTS AND REMEDIES.....	35
8	Optional equipment.....	38
8.1	PRECAUTIONS FOR OPTIONAL EQUIPMENT.....	38
8.2	HEATER.....	38
9	Technical data.....	42
9.1	REFERENCE CONDITIONS AND LIMITATIONS.....	42
9.2	ELECTRONIC WATER DRAIN DATA.....	42
10	Pressure equipment directives.....	45
11	Declaration of conformity.....	46

1 Safety precautions

1.1 Safety icons



Danger: Indicates an imminently hazardous situation which, if not avoided, will result in death or serious injury.



Warning: Indicates a potentially hazardous situation which, if not avoided, could result in death or serious injury.



Notice: Indicates a potential situation which, if not avoided, might result in property damage or in an undesirable result or state.



Note: Indicates important information.

1.2 General safety precautions



Danger: The condensate drain is under pressure. Suddenly escaping compressed air may result in serious injuries. Do not carry out mechanical or electrical work on the condensate drain as long as the condensate drain is under pressure.



Danger: Touching live parts might result in serious injury or death.



Danger: There is a risk of leakage of condensate into the environment. Water spots on the floor may be very slippery and result in serious fall injury. Water spots should be properly removed from the floor immediately.



Danger: Exceeding the maximum allowable operating conditions may result in serious injury or death. It is the duty of the operator to ensure that the operating pressure and temperature fall within the values provided by the condensate drain; these values are indicated on the identification plate.



Danger: Damages of the condensate drain may lead to unpredictable hazardous situations. Operating a damaged condensate drain may result in serious injury or death. Never start or operate a damaged condensate drain.



Danger: The condensate drain components are not designed to withstand any external overloads; the condensate drain may burst due to additional pressure. Any bursts of pressurized components may cause serious injuries and/or death. Transmission of loads or stress into the connections of the condensate drain is not permissible.



Warning: All responsibility for any damage or injury resulting from neglecting these precautions, or non-observance of the normal caution and care required for installation, operation, maintenance and repair, even if not expressly stated, will be disclaimed by the manufacturer.

- Read the instruction book carefully.
- The operator must employ safe working practices and observe all related local work safety requirements and regulations.
- If any of the following statements does not comply with local legislation, the stricter of the two shall apply.

- Installation, operation, maintenance and repair work must only be performed by authorised, trained, specialised personnel.
- Before carrying out any maintenance, repair work, adjustment or any other non-routine checks, stop the device. In addition, the power isolating switch must be opened and locked.

1.3 Safety precautions during installation

- The use of personal protection equipment (P.P.E.) during installation and maintenance operations is recommended.
- Install the equipment where the ambient air is cool and as clean as possible. Consult section Reference conditions and limitations.
- During installation or any other intervention on the equipment or one of the connected machines, the machines must be stopped, de-energized and the isolating switch opened and locked before any maintenance or repair. As a further safeguard, persons switching on remotely controlled machines shall take adequate precautions to ensure that there is no one checking or working on the machine. To this end, a suitable notice shall be affixed to the start equipment.
- Install the equipment in an area free of flammable fumes, vapours and particles, e.g. paint solvents, that can lead to internal fire or explosion.
- The electrical connections must correspond to the applicable codes. The equipment must be earthed and protected against short circuits by fuses in all phases. A lockable power isolating switch must be installed near the equipment.
- For machines controlled by a central control system, a sign stating "This machine may start without warning" must be affixed near the instrument panel.
- In multiple compressor systems, manual valves must be installed to isolate each compressor. Non-return valves (check valves) must not be relied upon for isolating pressure systems.
- Never remove or tamper with the safety devices.
- If the maximum pressure of the compressor is higher than the design pressure of the connected equipment (e.g. a nitrogen generator or an oxygen generator), a full flow safety valve must be installed between the compressor and the connected equipment, in order to be able to blow off the excessive pressure.
- Only use pressure-proof installation material. The feed line must be firmly fixed. The discharge line should be a short pressure hose or a pressure-proof pipe. Ensure that the condensate cannot squirt onto persons or objects.
- Avoid excessive tightening of the connectors on the inlet and outlet. When tightening the connectors, two keys have to be used: one to hold the valve, the other to tighten the nut.
- In areas where freezing temperatures are expected, the device should be provided with thermostatically controlled heating (optional equipment).
- During electric installation, all regulations in force need to be adhered to (e.g. VDE 0100 / IEC 60364).



Note: Also consult following safety precautions: Safety precautions during operation and Safety precautions during maintenance or repair.



Note: The precautions apply to electrical devices.



Note: For precautions applying to the connected equipment, consult the relevant instruction book.



Note: Some precautions are general and cover several machine types and equipment; hence some statements may not apply to your device.

1.4 Safety precautions during operation



Warning: All responsibility for any damage or injury resulting from neglecting these precautions, or non-observance of the normal caution and care required for installation, operation, maintenance and repair, even if not expressly stated, will be disclaimed by the manufacturer.

- Persons switching on remotely controlled machines shall take adequate precautions to ensure that there is no one checking or working on the machine. To this end, a suitable notice shall be affixed to the remote start equipment.
- Never operate the device in the presence of flammable or toxic fumes, vapours or particles.
- Never operate the device below or in excess of its limit ratings.
- Keep all bodywork doors and panels closed during operation. The doors may be opened for short periods only, e.g. to carry out routine checks.
- People staying in environments or rooms where the equipment is operated shall wear adequate personal protective measures, such as ear protection, safety goggles, etc.
- Periodically check that:
 - All guards and fasteners are in place and tight.
 - All hoses and/or pipes are in good condition, secure and not rubbing.
 - There are no leaks.
 - All external electrical leads are secure and in good order.
- Never remove or tamper with the safety devices.
- The electronic drain valve will only function when voltage is being supplied to the device.
- Do not use the test button for continuous draining.
- Do not use the electronic drain valve in hazardous areas (with potentially explosive atmospheres).



Note: Also consult following safety precautions: Safety precautions during installation and Safety precautions during maintenance or repair.



Note: The precautions apply to electrical devices.



Note: For precautions applying to the connected equipment, consult the relevant instruction book.



Note: Some precautions are general and cover several machine types and equipment; hence some statements may not apply to your device.

1.5 Safety precautions during maintenance or repair



Warning: All responsibility for any damage or injury resulting from neglecting these precautions, or non-observance of the normal caution and care required for installation, operation, maintenance and repair, even if not expressly stated, will be disclaimed by the manufacturer.

- The use of personal protection equipment (P.P.E.) during installation and maintenance operations is recommended.
- Use only the correct tools for maintenance and repair work.
- Use only genuine spare parts.

- A warning sign bearing a legend such as "Work in progress - do not start" shall be attached to the starting equipment, including all remote start equipment.
- Persons switching on remotely controlled machines shall take adequate precautions to ensure that there is no one checking or working on the machine. To this end, a suitable notice shall be affixed to the remote start equipment.
- Never use flammable solvents or carbon tetrachloride for cleaning parts. Take safety precautions against toxic vapors of cleaning liquids.
- Scrupulously observe cleanliness during maintenance and repair. Keep dirt away by covering the parts and exposed openings with a clean cloth, paper or tape.
- Never use a light source with open flame for inspecting the interior of the device.
- All regulating and safety devices shall be maintained with due care to ensure that they function properly. They may not be put out of action.
- Before clearing the device for use after maintenance or repair, check that operating pressures, temperatures and time settings are correct. Check that all control and shutdown devices are fitted and that they function correctly.
- Make sure that no tools, loose parts or rags are left in or on the device.
- Never use caustic solvents which can damage materials of the device.
- Do not exceed the maximum operating pressure. Maintenance work may only be carried out when the device is not under pressure.
- All maintenance work must only be undertaken when the device is in a de-energized condition.
- Before removing any pressurized components, effectively isolate the device from all sources of pressure and relieve the system of pressure.



Note: Also consult following safety precautions: Safety precautions during installation and Safety precautions during operation.



Note: The precautions apply to electrical devices.



Note: For precautions applying to the connected equipment, consult the relevant instruction book.



Note: Some precautions are general and cover several machine types and equipment; hence some statements may not apply to your device.

1.6 Dismantling and disposal

The device must be disposed according to local regulations. The product is not designed for refurbishing after finished lifecycle.

Dismantling

Once the end of life of the machine is reached, please follow next steps:

1. Stop the machine.
2. Check all safety precautions mentioned in the previous chapters to secure safe handling (e.g. LOTO, cool-down, depressurize, discharge, etc.).
3. Have trained personnel dismantle the installation.
4. Separate the harmful from the safe components (e.g. drain oil from parts containing oil).
5. Refer to the disposal topic below.

Disposal of electrical and electronic appliances (WEEE)

This equipment falls under the provisions of the European Directive 2012/19/EU on waste electrical and electronic appliances (WEEE) and may not be disposed as unsorted waste.



The equipment is labelled in accordance with the European Directive 2012/19/EU with the crossed-out wheeled bin symbol.

At the end of life-time of the electric and electronic equipment (EEE) it must be taken to separate collection.

For more information check with your local waste authority, customer center or distributor.

Disposal of other used material

Used filters or any other used material (e.g. filter bags, filter media, desiccant, lubricants, cleaning rags, machine parts, etc.) must be disposed of in an environmentally friendly and safe manner, and in line with the local recommendations and environmental legislation.

2 General description

2.1 Functional description

General



These condensate drains have been engineered to solve the problem of discharging condensed water from production plants and compressed air distribution systems. The specific applied technology permits a controlled drainage of condensate without any waste of compressed air.

The condensate drain is equipped with a built-in storage tank, inside which a level sensor has been mounted and is controlled by an intelligent electronic circuit based on a microprocessor logic. All condensate drain functions are displayed on the control panel that is moreover equipped with a test push button for manual drainage.

The condensate drain starts working as soon as the sensor detects water at the maximum level and activates the opening of the solenoid valve to take the water level back down to a minimum value, leaving a small residual quantity to prevent the system from discharging compressed air.

In the event of any fault, the control circuit activates the unclogging of possibly clogged drain pipes by carrying out a series of forced opening/closing cycles of the solenoid valve. If this is not sufficient, the fault is reported externally by means of a potential-free contact alarm that can be used to draw the attention of maintenance staff in order to instruct the plant system's control logic.

The drain may also be installed on applications that produce very aggressive condensates, such as oil-free compressors. The presence of a built-in, easy to clean filter cup prevents the solenoid valve from clogging.

Main characteristics

- Zero loss drain system.
- Logic based on an 8-bit microprocessor which records events on an integral flash memory.
- Revolving "Easy-Lock" connection.
- Integrated filter for the collection of impurities for easy maintenance.
- Fluoroelastomer (FKM) diaphragm.
- Remote alarm connection for warning.
- Tank in aluminium with a treatment for operating with aggressive condensation.
- Secondary condensate input that is ideal for low attachment points. (Not for NED 4L and NED 6LC.)

Operation

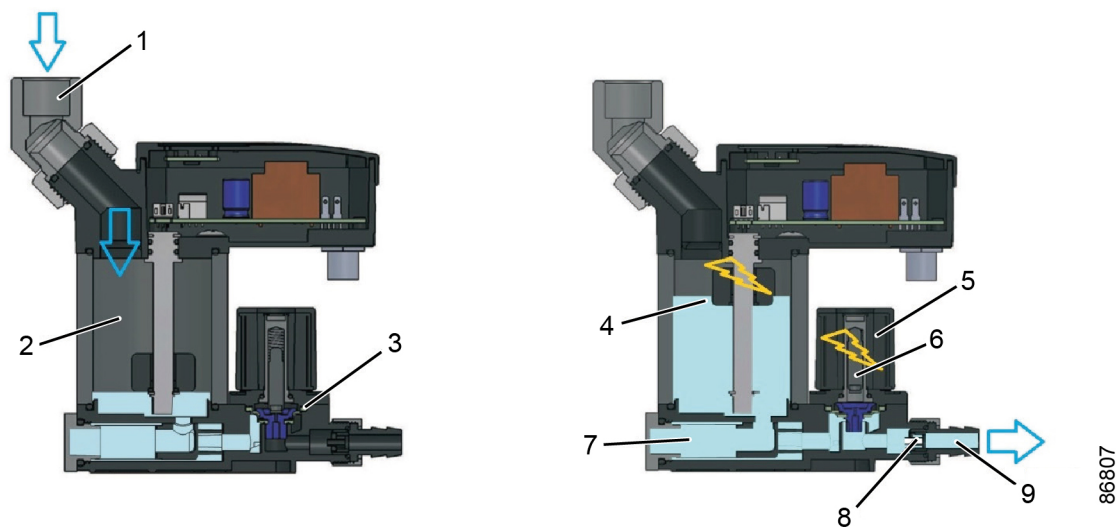

Figure 1: Condensate drain, standby mode and discharge mode

The drain is connected to the point where the elimination of the condensate is required (tank, filter, dryer, etc.), by means of the connection supplied (1).

The accumulation tank (2) collects the condensation and the diaphragm (3) keeps the drainage hole closed thanks to the pressure exerted on its surface.

As the liquid level rises the float (4) rises and, as soon as it has reached the maximum filling level, the solenoid (5) is triggered by means of the logic control circuit, to open the pilot valve (6).

As compensation is lacking, the diaphragm is lifted allowing the discharge of water to bring the level in the tank back to a minimum (3), to then close the passage of the discharge without letting air escape.

The product is also equipped with two components that are very useful for ensuring functionality and reliability.

An integrated filter cup (7) and a flow regulator (8) inserted into the hose holder (9). The first is used to retain the impurities contained in the condensate, to ensure a perfect operation of the valve even in the most critical applications. The second, instead, is used to control the discharge flow, slowing the purging to avoid an additional oil emulsion that, in most cases, is present in the condensate water.

By pressing the test button it is also possible to manually actuate the discharge in order to control the functionality; it can be also useful for unblocking in the event of faulty operation.

3 Control panel

3.1 Description

NED 4L

The control panel on top of the drain includes a multifunction button and two state display LEDs.

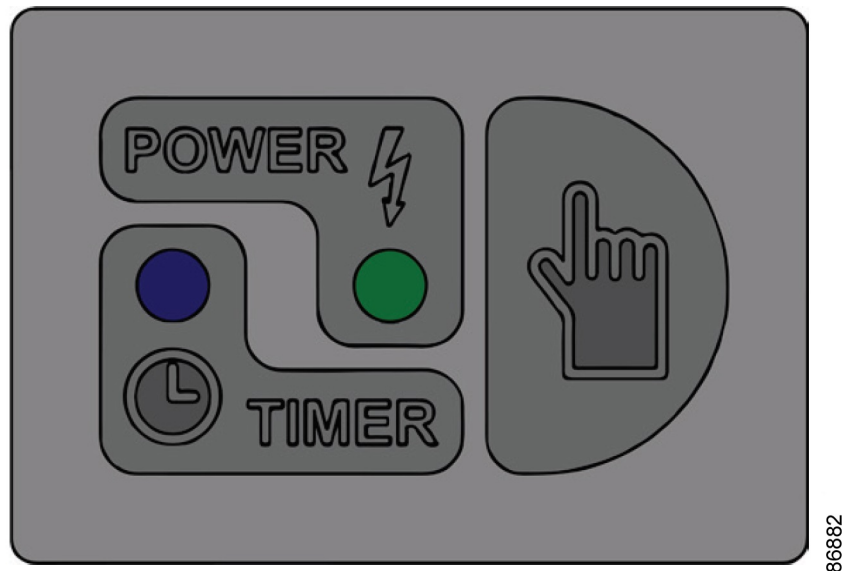

- **Green LED**

This LED is on when the drain is powered and during its normal function.

- **Blue LED**

This LED is on when the drain is in timer mode. Timer mode is active when the cleaning routine has not solved an anomaly.

- **Multifunction button**

- If pressed during normal operation, manual drainage starts.
- If pressed for 5 seconds, it resets the logic of the microprocessor.

NED 6LC - NED 350L

It is possible to monitor the operation of the condensate drain at any time thanks to a control panel, which includes two status display LEDs, and a multifunctional button.

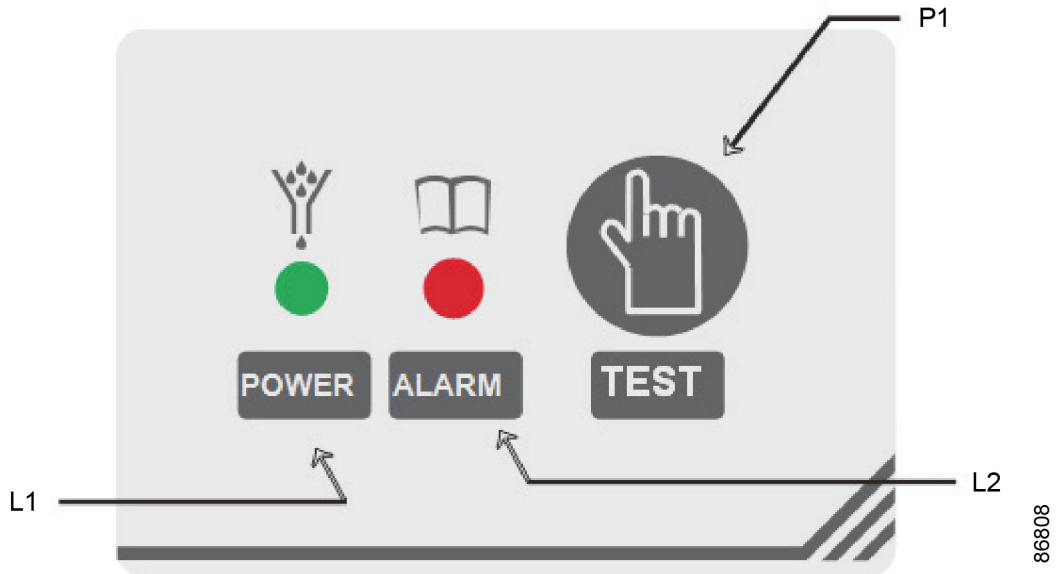

Reference	Description
L1	Green LED Power status indicator
L2	Red LED Alarm indicator
P1	Multifunctional test button

3.2 Operation logic

NED 4L

Power on

The CPU of the drain starts-up and loads the internal data.

Green LED	Blinks 3 times.
Blue LED	Blinks 2 times.
Purge valve	-

Standby

The drain is ready to operate: activation through floater movement. Every 30 minutes a routine to keep the drain clean from oil/ condensate residuals starts.

Green LED	On
Blue LED	-
Purge valve	1. On for 2 seconds. 2. Off for 30 seconds.

Automatic discharge

The drain is ready to operate: activation through floater movement. Every 30 minutes a routine to keep the drain clean from oil/ condensate residuals starts.

Green LED	On
Blue LED	-
Purge valve	On until the condensate chamber is almost empty.

Cleaning routine

If the floater is stuck at the top, after 10 sec the drain starts a cleaning operation. When the floater moves down, that routine stops immediately and the drain goes to standby.

Green LED	On
Blue LED	-
Purge valve	<ol style="list-style-type: none"> 1. On for 2 seconds, off for 2 seconds. (This is repeated 30 times.) 2. Paused for 1 minute. 3. On for 2 seconds, off for 2 seconds. (This is repeated 30 times.)

Timer routine

If the floater is still stuck after the cleaning routine has been completed, the drain switches to the timer routine. When the floater moves down, that routine stops immediately and the drain goes to standby.

Green LED	-
Blue LED	On
Purge valve	<ol style="list-style-type: none"> 1. On for 1 second. 2. Off for 60 seconds.

Manual discharge

Press the test button to discharge manually. The drain discharges condensate for 1 second, even if test button remains pressed. To discharge for more than 1 second, you need to press test button repeatedly.

Green LED	On
Blue LED	-
Purge valve	On until the test button is pushed.

Reset

Press the test button for 5 seconds to reset the drain.

Green LED	1. Both LEDs are off for 2 seconds.
Blue LED	<ol style="list-style-type: none"> 2. The green LED blinks 3 times. 3. The blue LED blinks 2 times.
Purge valve	-

NED 6LC - NED 350L**Power on**

The condensate drain is powered on.

L1	The green and red LED flash one after the other for 5 seconds.
L2	
P1	-
Valve	-
Alarm	-

Normal operation

The condensate drain is operating normally.

L1	On
L2	-
P1	-
Valve	-
Alarm	-

Supply voltage missing

The condensate drain is disconnected from the power supply. The operating functions are deactivated. An alarm signal is remotely transmitted.

L1	-
L2	-
P1	-
Valve	-
Alarm	On

Standby

There is no condensate. The supply voltage is applied and the condensate drain is ready to operate. If no condensate is discharged for 3 hours, the software performs a brief forced discharge. The green LED is continuously on and the condensate drain activates the same routine until there is a normal discharge that brings the sensor back to the minimum level.

L1	On
L2	-
P1	-
Valve	<ol style="list-style-type: none"> 1. Off for 3 hours. 2. On for 2 seconds.
Alarm	-

Automatic condensate discharge

The maximum level is reached. The valve opens (with a delay of 10 seconds) and the condensate is discharged. The valve closes as soon as the minimum level is reached.

L1	Flashing slowly
L2	-
P1	-
Valve	On for a maximum of 20 seconds.
Alarm	-

Cleaning routine 1

Even if the valve is opened, the minimum level is not reached within 20 seconds. The condensate drain tries with repeated on/off cycles to unblock the situation probably caused by clogging.

L1	-
L2	Flashing slowly
P1	-
Valve	<ol style="list-style-type: none"> 1. On for 2 seconds. 2. Off for 2 seconds. 3. Repeated 30 times.
Alarm	-

Cleaning routine 2

After cleaning routine 1, the minimum level has not been reached. The condensate drain continues to operate as a timer, continuing with the on/off sequence and continues with alarm modalities.

L1	-
L2	Flashing quickly
P1	-
Valve	<ol style="list-style-type: none"> 1. On for 3 seconds. 2. Off for 60 seconds.
Alarm	On

Irreversible error

A fault has occurred in the system. Try with the reset function. If the problem reoccurs, a technical intervention is required.

L1	-
L2	On
P1	-
Valve	<ol style="list-style-type: none"> 1. On for 3 seconds. 2. Off for 60 seconds.
Alarm	On

Manual condensate draining

When the test button is pressed, the condensate is discharged manually.

L1	Flashing quickly
-----------	------------------

L2	-
P1	On for a maximum of 3 seconds.
Valve	On for a maximum of 3 seconds.
Alarm	-

Reset

When a reset in an alarm state is required. If the problem persists, the alarm state will be reactivated after a short period.

L1	Green and red LED sequence and then the green LED is on.
L2	
P1	On for more than 5 seconds.
Valve	-
Alarm	-

3.3 Flow chart

1. Drain powered.
Red and green LED alternating on/off for 6 seconds.
2. Is the water level increasing?

Option	Description
Yes	Solenoid energized with 10s delay, continue with step 3
No	After 3 hours, valve open for 2 seconds, continue with step 4.

3. Is the drain draining water?

Option	Description
Yes	Drain works
No	The level of the water is high and the drain does not drain water. An attempt to open the valve is made for 20 seconds. Continue with step 5.

4. Is water discharging?

Option	Description
Yes	Drain works
No	Go to step 2, No: in loop for 5 times then LED stays in green.

5. Is water discharging?

Option	Description
Yes	Drain works
No	Start cleaning routine 1: Drain attempts to open and close the valve according to following scheme: 30 cycles <ul style="list-style-type: none"> • 2 sec: open • 2 sec: closed Total routine time: 2 min Continue with step 6.

6. Is water discharging?

Option	Description
Yes	Drain works
No	Start cleaning routine 2: Drain attempts to open and close the valve according to following scheme: Unit drain restarts discharging





Option	Description
	<ul style="list-style-type: none"> • 3 sec: open • 60 sec: closed Total routine time: infinite External free contact opens. Continue with step 7.

7. Is water discharging?

Option	Description
Yes	Drain works
No	Drain remains in cleaning routine 2 until drain ejects water or is serviced/repaired.

4 Installation

4.1 Installation proposal

-  **Danger:** Installation or maintenance work can only be carried out by trained and qualified staff who must follow the procedures of this manual and use proper safety and protection equipment.
-  **Danger:** Disconnect the electrical power supply as well as the air plant system before any installation or maintenance works.
-  **Danger:** Do not use the condensate drain in hazardous areas with potentially explosive indoor or outdoor atmospheres. The condensate drain has not been engineered in accordance with the ATEX standard.
-  **Danger:** Only use pressure-proof installation materials! The feed line must be firmly fixed. Outlet line: short pressure hose to pressure-proof pipe. Ensure that condensate cannot squirt onto persons or objects.
-  **Note:** Do not discharge the condensate into the environment: the condensate water may contain pollutants. Comply with local regulations and legislation.

Procedure

1. Connect the inlet fitting of the condensate drain to the condensate collection point required, using the compliant equipment.

Do not use the condensate drain as a lever.

In order to facilitate the installation, the drain is supplied with the revolving Easy-Lock connection with an O-ring.

2. Connect the outlet hose fittings of the condensate drain to the condensate collection point, using a rubber hose with a diameter of 10 to 12 mm.

Remarks

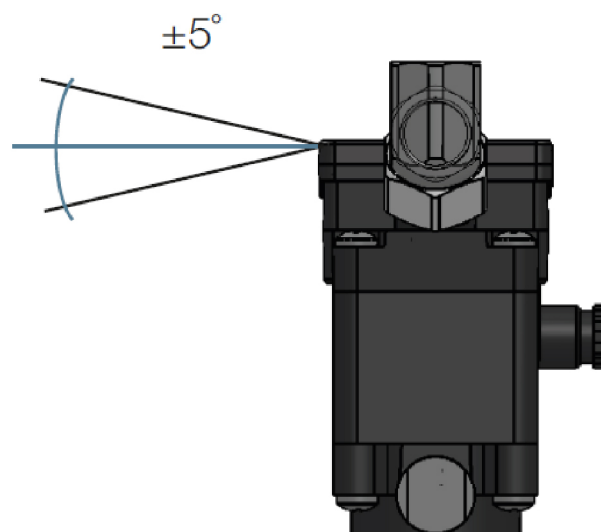

60809

The condensate drain must be mounted vertically, with the inlet upward and with a maximum of $\pm 5^\circ$ inclination.

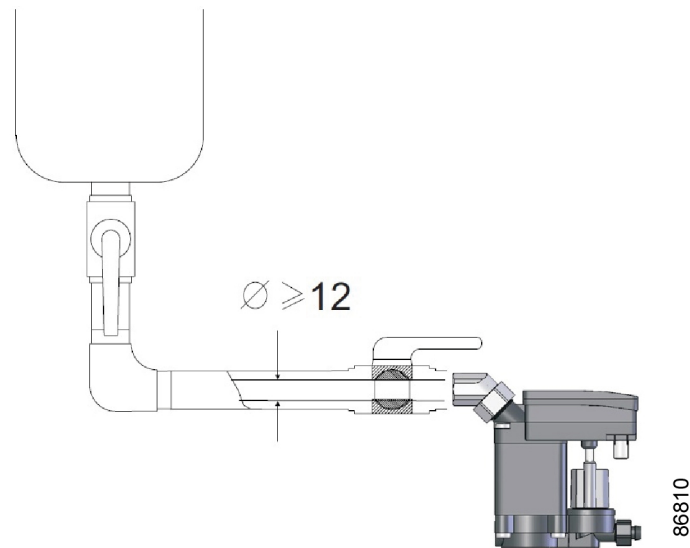

The diameter of the inlet pipe must be at least 12 mm.

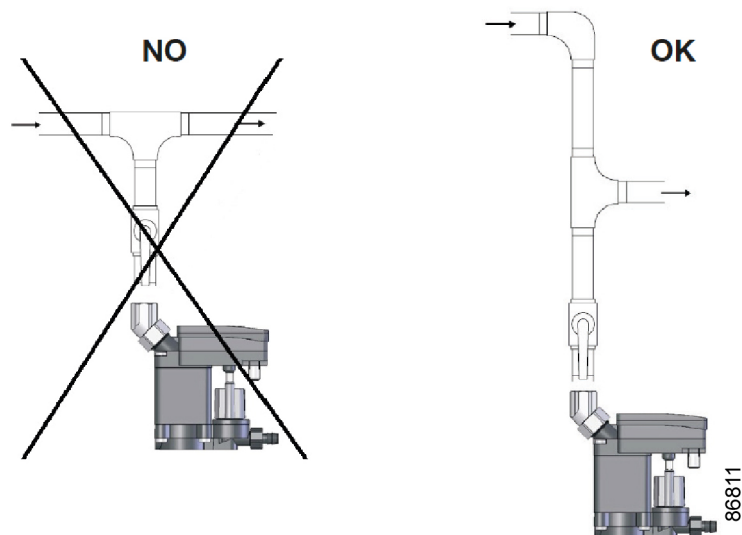

With the condensate drain connected directly to the line, it is preferable to modify the plant in such a way as to deflect the air flow and to make it possible for the condensate to collect in the lower point.

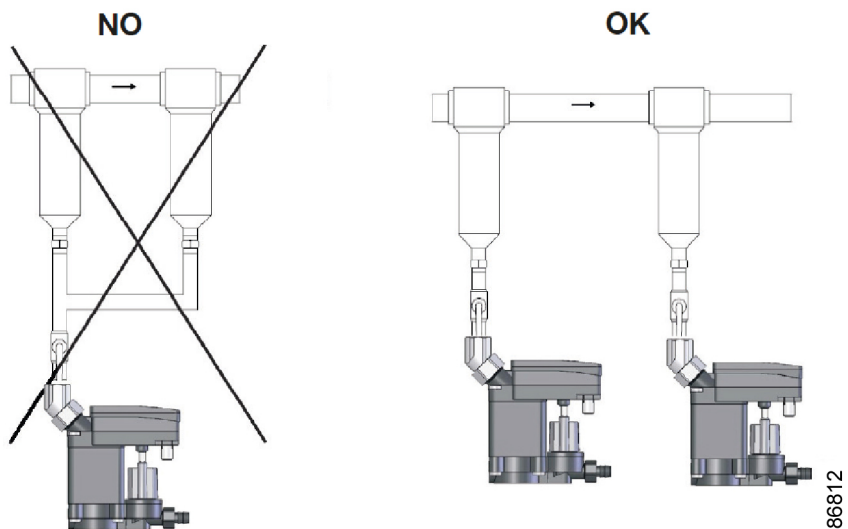

Do not connect only one condensate drain to two points with different pressures in such a way as to avoid the creation of by-pass flows.

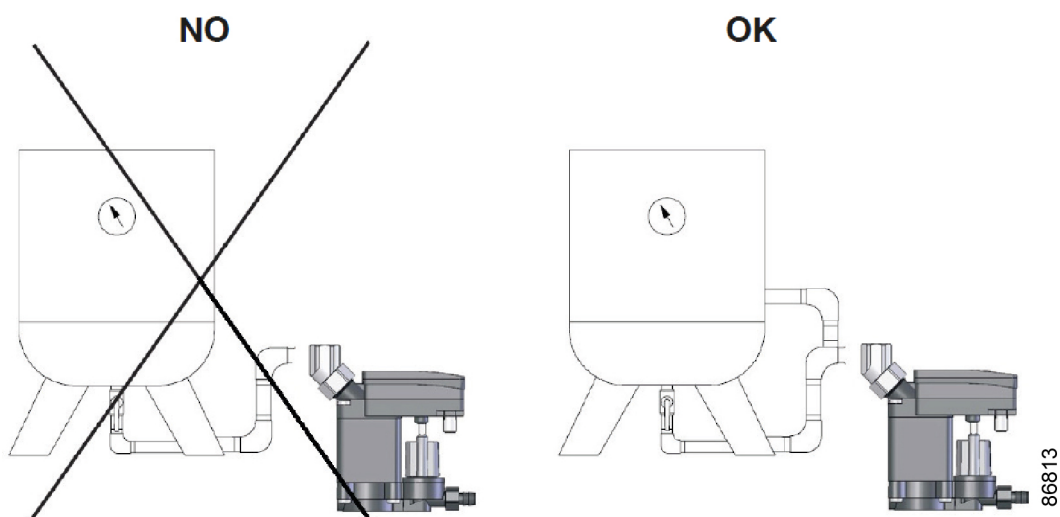

In case there is no adequate slope, it is necessary to use a secondary pipe for air compensation.

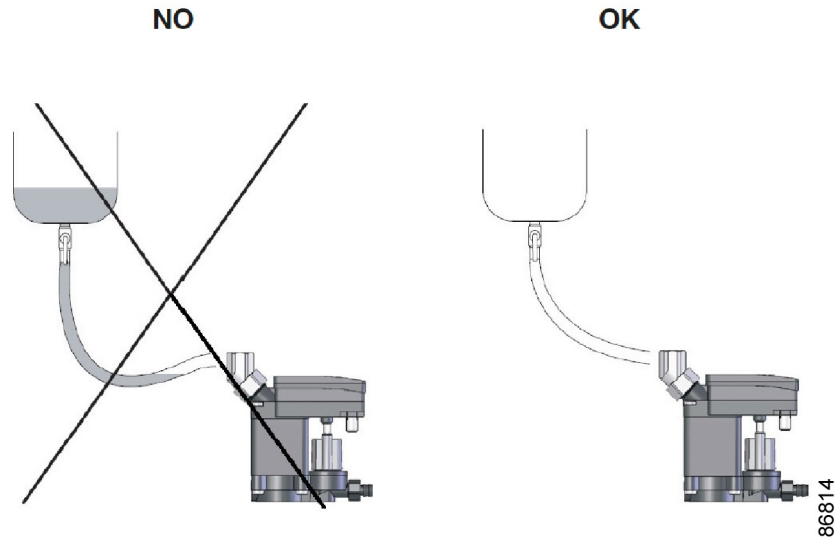

In the case of a flexible inlet pipe, be careful to avoid folds being formed in order to avoid pockets of water being formed.

4.2 Dimension drawings

NED 4L

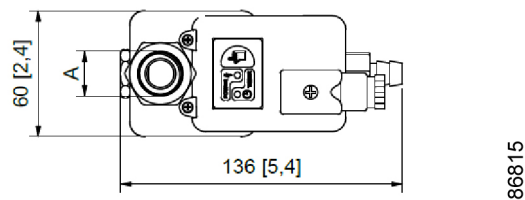
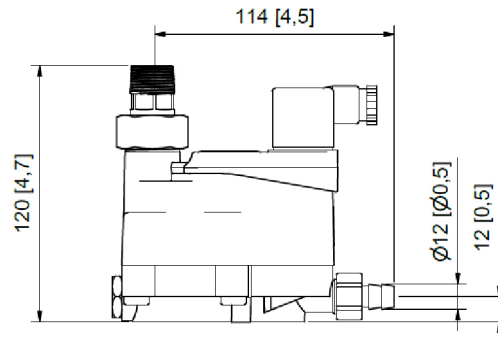

Product number	Item number	Model	Power supply	Inlet A
8102 0482 01	4001 1652 01	NED 4L B12 230V	240V AC	R 1/2" M
8102 0482 02	4001 1652 02	NED 4L N12 115V	115V AC	NPT R 1/2" M

Product number	Item number	Model	Power supply	Inlet A
8102 0482 03	4001 1652 03	NED 4L B12 24Vac	24V AC	R ½" M
8102 0482 04	4001 1652 04	NED 4L B12 24Vdc	24V DC	R ½" M

NED 6LC

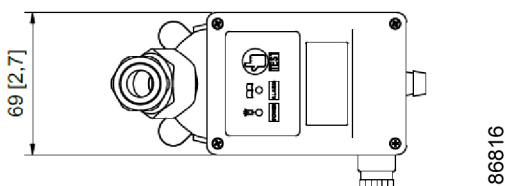
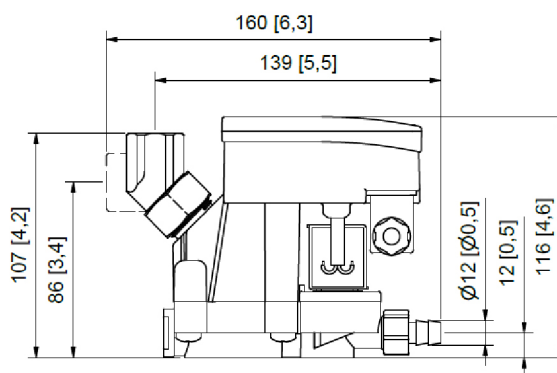

Product number	Item number	Model	Power supply	Inlet A
8102 0482 11	4001 1652 11	NED 6LC B12 230V	240V AC	G ½" F
8102 0482 12	4001 1652 12	NED 6LC N12 115V	115V AC	NPT R ½" F
8102 0482 13	4001 1652 13	NED 6LC B12 24Vac	24V AC	G ½" F
8102 0482 14	4001 1652 14	NED 6LC B12 24Vdc	24V DC	G ½" F

NED 8LC

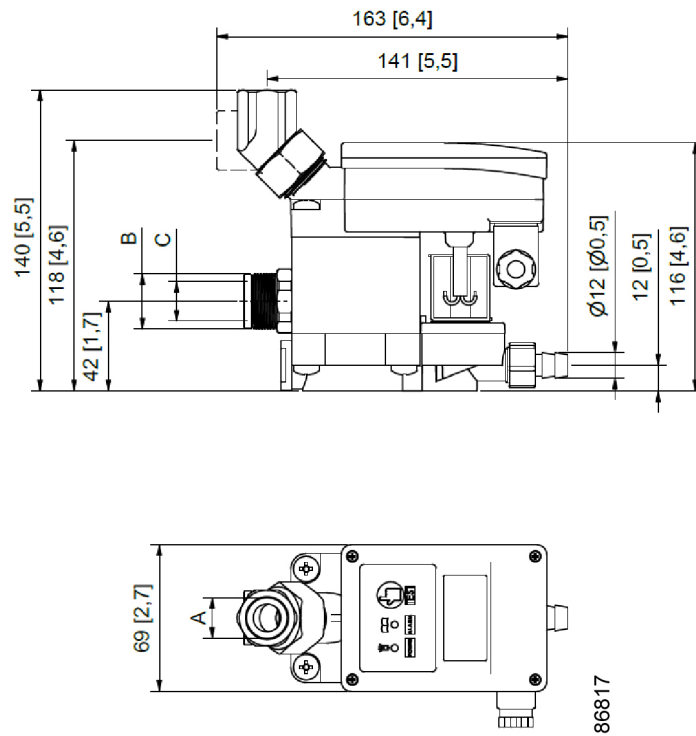

Product number	Item number	Model	Power supply	Inlet A	Inlet B	Inlet C
8102 0482 21	4001 1652 21	NED 8LC B12 230V	240V AC	G ½" F	G ¾" M	G ½" F
8102 0482 22	4001 1652 22	NED 8LC N12 115V	115V AC	NPT R ½" F	-	NPT R ½" F
8102 0482 23	4001 1652 23	NED 8LC B12 24Vac	24V AC	G ½" F	G ¾" M	G ½" F
8102 0482 24	4001 1652 24	NED 8LC B12 24Vdc	24V DC	G ½" F	G ¾" M	G ½" F

NED 16LC

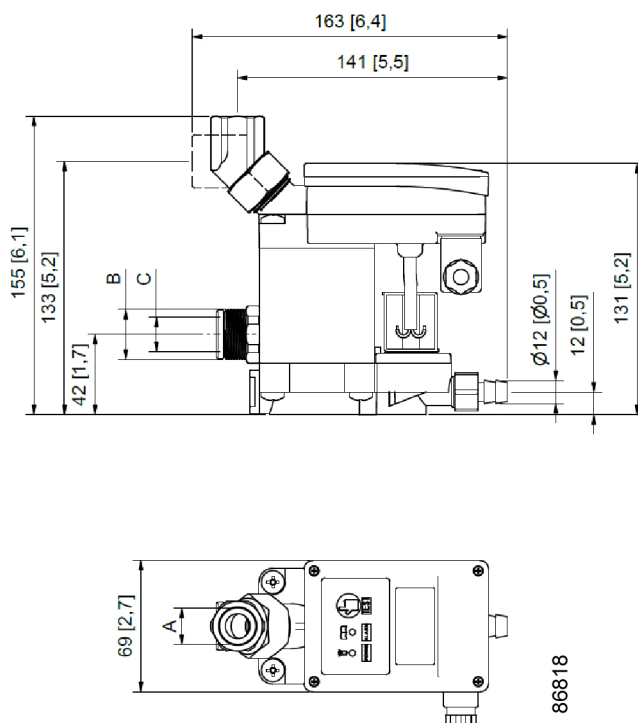

Product number	Item number	Model	Power supply	Inlet A	Inlet B	Inlet C
8102 0482 31	4001 1652 31	NED 16LC B12 230V	240V AC	G 1/2" F	G 3/4" M	G 1/2" F
8102 0482 32	4001 1652 32	NED 16LC N12 115V	115V AC	NPT R 1/2" F	-	NPT R 1/2" F
8102 0482 33	4001 1652 33	NED 16LC B12 24Vac	24V AC	G 1/2" F	G 3/4" M	G 1/2" F
8102 0482 34	4001 1652 34	NED 16LC B12 24Vdc	24V DC	G 1/2" F	G 3/4" M	G 1/2" F

NED 40LC

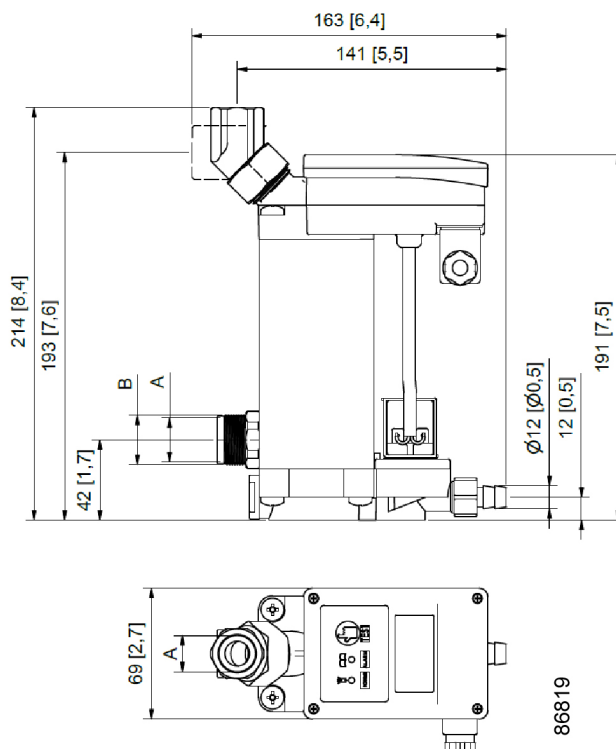

Product number	Item number	Model	Power supply	Inlet A	Inlet B	Inlet C
8102 0482 41	4001 1652 41	NED 40LC B12 230V	240V AC	G 1/2" F	G 3/4" M	G 1/2" F
8102 0482 42	4001 1652 42	NED 40LC N12 115V	115V AC	NPT R 1/2" F	-	NPT R 1/2" F
8102 0482 43	4001 1652 43	NED 40LC B12 24Vac	24V AC	G 1/2" F	G 3/4" M	G 1/2" F
8102 0482 44	4001 1652 44	NED 40LC B12 24Vdc	24V DC	G 1/2" F	G 3/4" M	G 1/2" F

NED 160LC

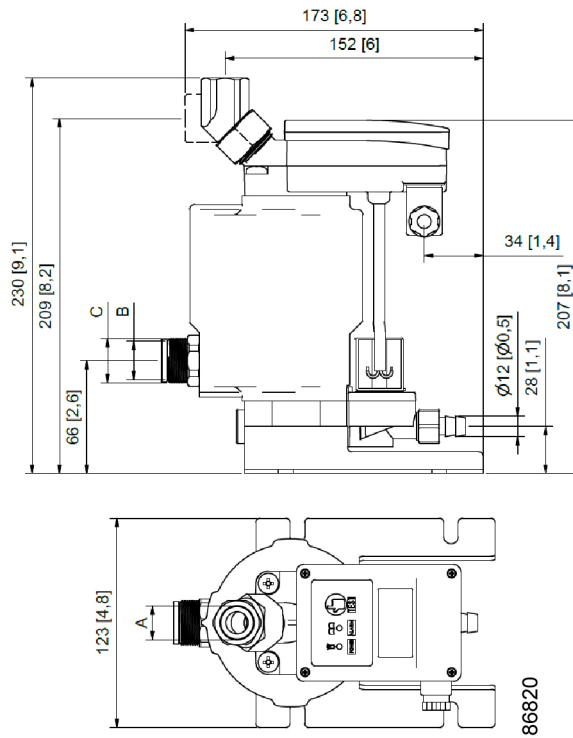

Product number	Item number	Model	Power supply	Inlet A	Inlet B	Inlet C
8102 0482 51	4001 1652 51	NED 160LC B12 230V	240V AC	G 1/2" F	G 3/4" M	G 1/2" F
8102 0482 52	4001 1652 52	NED 160LC N12 115V	115V AC	NPT R 1/2" F	-	NPT R 1/2" F
8102 0482 53	4001 1652 53	NED 160LC B12 24Vac	24V AC	G 1/2" F	G 3/4" M	G 1/2" F
8102 0482 54	4001 1652 54	NED 160LC B12 24Vdc	24V DC	G 1/2" F	G 3/4" M	G 1/2" F

NED 350L

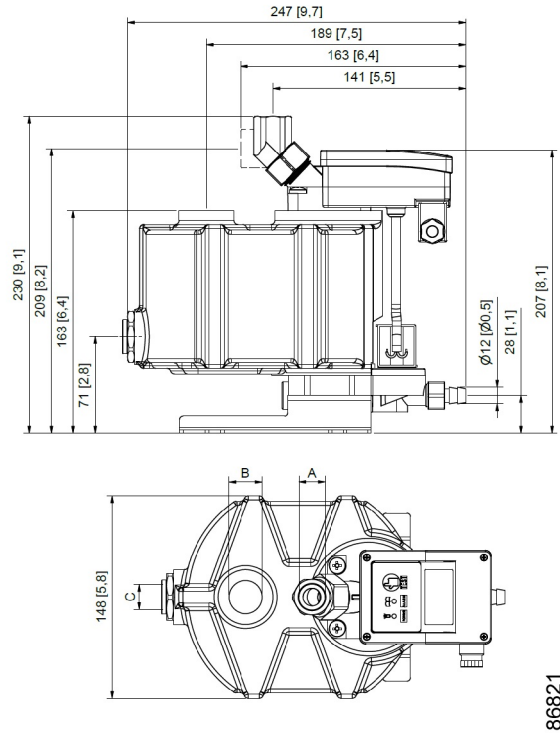

86821

Product number	Item number	Model	Power supply	Inlet A	Inlet B	Inlet C
8102 0482 61	4001 1652 61	NED 350L B12 230V	240V AC	G 1/2" F	G 3/4" F	G 1/2" F
8102 0482 62	4001 1652 62	NED 350L N12 115V	115V AC	NPT R 1/2" F	G 3/4" F	G 1/2" F
8102 0482 63	4001 1652 63	NED 350L B12 24Vac	24V AC	G 1/2" F	G 3/4" F	G 1/2" F
8102 0482 64	4001 1652 64	NED 350L B12 24Vdc	24V DC	G 1/2" F	G 3/4" F	G 1/2" F

4.3 Electrical connections

- Danger:** Disconnect the electrical power supply as well as the air plant system before any installation or maintenance works.
- Danger:** Installation or maintenance work can only be carried out by trained and qualified staff who must follow the procedures of this manual and use proper safety and protection equipment.
- Danger:** Protect the internal parts from humidity when the cover is removed for making the connections.
- Danger:** In case of 24 V DC operation, do not connect the positive wire to the frame because the internal housing potential of the device is negative.

The supply voltage must meet the requirements for protective extra-low safety voltages (PELV) in accordance with IEC 60364-4-41.



Danger: In case of AC supply, a reliably accessible separator must be provided close-by (e.g. power plug or switch), which separates all current carrying conductors.



Danger: If the potential-free contact carries voltage that is dangerous in the case of contact, a corresponding separator must also be provided.



Danger: Between the protective conductor/PE connection and the piping, a potential difference is not admissible. If required, potential equalization in accordance with VDE 0100 / IEC 60364 must be provided for.



Danger: Before starting any maintenance or repairs, close the air outlet valve and press the test button on top of the electronic water drain to depressurize the air system.

The condensate drains are supplied with different power supply values. This value is stated on the identification plate applied on each one. Before powering up the condensate drain, please ensure that these values correspond to those on the identification plate. Make sure that the identification plate is always clearly visible.

In order to ensure IP65 class protection and prevent any electrical shock from accidental contact, follow these instructions:

- Make sure that all cables are correctly inserted into the connector terminals and that it is carried out by qualified and authorized personnel.
- Make sure that the gasket seal between the electronics and connector compartment is in place.
- Close the M3 screw of the power supply connector with a 45cN ± 5cNm tightening torque.
- The electronic board is sealed off from external agents, and should not be opened.
- All electrical connections can be made from the outside by means of suitable connectors.

Should all or part of the above be totally or partially lacking, malfunctions may be generated due to condensate infiltrations.

Power supply

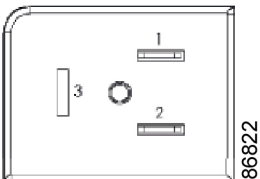
Contact	2 poles, phase and neutral with either polarity. Connect with insulated cable, minimum 2 x 0.5 mm ² .
View, condensate drain side	
Pin-out, condensate drain side	1 = Phase/neutral any polarity
	2 = Neutral/phase any polarity
	3 = Not connected
Connector	Industrial form connector of type B/ISO 6952 11mm standard EN 175301-803 (ex DIN 43650). The connector is supplied as an accessory.

View, connector side	 <p style="text-align: right;">86823</p>
Pin-out, connector side	 <p style="text-align: right;">86824</p>

Table 1: Connection of the power supply



Note: Mount the connector seal and tighten the fastening screw with the recommended tightening torque.

Alarm contact

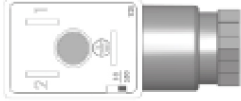

Contact	Normally closed (NC)/ Normally open (NO) contact, relay energized in normal operation, not energized in alarm mode. 240 VAC, maximum 1 A 30 VDC, maximum 1 A	
View, condensate drain side	 <p style="text-align: right;">86825</p>	
Pin-out, condensate drain side	1 = Common	
	2 = Normally closed (NC)	
	3 = Normally open (NO)	
	4 = Not connected	
Connector	Female connector M12, Code A, 4 standard poles IEC 61076-2-101. The cable is not supplied as an accessory.	
View, connector side	 <p style="text-align: right;">86826</p>	
Pin-out, connector side	 <p style="text-align: right;">86827</p>	
	1 = Brown	
	2 = White	
	3 = Blue	
4 = Black		

Table 2: Connection of the alarm contact

Contact	1-2	1-3
Condensate drain status	Contact status	
Not powered	Closed	Open
Powered	Open	Closed
Alarm	Closed	Open

Table 3: Status of the alarm contact

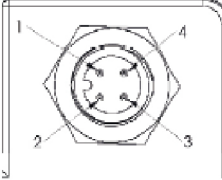
5 Operating instructions

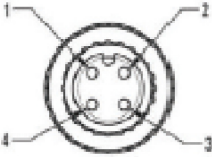
5.1 Commissioning

Powering the drain

1. Check that the supply voltage corresponds to the value indicated on the identification plate.
2. Ensure that there is a seal gasket between the solenoid valve connector and the electrical compartment.

Pressurizing the drain

1. Make sure that the condensate drain has been installed correctly.
2. Make sure that the plant system is under pressure.
3. Open the pressure supply valve slowly. When the pressure no longer increases, open it clearly.
4. Check to see if any leaks are detected. If so, the condensate drain must be depressurized in order to repair the leaks. For the depressurization, see subsequent phases.
5. The condensate drain is now ready to use.

5.2 Shutting down

In the event of a shutdown and disassembly of the condensate drain, follow the subsequent steps:

1. Close the pressure supply valve of the condensate drain.
2. Depressurize the condensate drain by repeated presses of the TEST button until no further discharge noises are heard. Pay attention that a quantity of residual pressure might remain in the condensate drain.
3. Turn off the power supply.
4. Now the condensate drain may be disassembled.

6 Maintenance

6.1 Maintenance activities



Danger: Before starting any maintenance or repairs, close the air outlet valve and press the test button on top of the electronic water drain to depressurize the air system.



Danger: Installation or maintenance work can only be carried out by trained and qualified staff who must follow the procedures of this manual and use proper safety and protection equipment.



Note: Apply all relevant instructions in section Safety precautions.

The set of wearing parts (service kit) must be changed every 4000 hrs or yearly, whichever comes first.

Please observe the following requirements for maintenance:

- Use P.P.E. (personal protective equipment).
- Read this manual in full.
- Maintenance must only be carried out if the condensate drain is depressurized and disconnected from the electrical power supply.
- Follow the instructions regarding the shut down. See section Shutting down.
- Carry out maintenance operations with the condensate drain placed on a clean work counter that is easily accessible.
- Ensure that all connections and threaded joints have been tightened correctly and with the related seals are in place.
- If any air leaks are heard, carry out a leak control.
- Follow the start up instructions. See section Commissioning.

Maintenance intervals

The following table seeks to provide a summary of the recommended maintenance activities for preventing malfunctions and/or the possible breaking of components susceptible to wear and tears. These activities are described in detail in the following pages.

Component	Maintenance activity	Daily	Monthly	Yearly*
Condensate drain	Visual check and function verification.	X		
Integrated filter	Cleaning and/or substitution of the filter.		X	
Condensate drain	Replace worn out components, subject to wear and tear and clean condensate drain.			X

* in the event of applications that are particularly heavy, dirty, and poorly ventilated, it should also be foreseen that this frequency is doubled.

Visual inspection and verification of the correct operation

1. Inspect the condensate drain for external damages and leaks.
2. Check the operating state of the condensate drain by means of the LED displays on the control panel. See section Control panel.
3. Push the TEST button in order to verify the operating status of the discharge and the correct operation of the valve. In the event of faults, see section Problem solving.

Cleaning and/or substitution of the integrated filter

1. Unscrew the cap.
2. Clean the filter or, if necessary, replace it.
3. First, place the cleaned filter back in its seat on the cap.
4. Screw in the lockable cap with the filter paying attention to not damage the plastic threading of the valve body.

Replacement of parts subject to wear and tear and cleaning the condensate drain

1. Open the condensate drain, unscrewing the 4 M6x25 screws (12) as well as the M3x10 screws (13) and remove the valve assembly (11).
2. Unscrew the filter cap (04) and extract the integrated filter.
3. Remove the O-Ring gasket of the valve assembly (07), the O-Ring gasket of the filter cap, the solenoid valve spring (08), the solenoid valve pilot (09) and the diaphragm with the diaphragm guide (10).
4. Clean the internal housing of the valve assembly and the aluminium tank.
5. If necessary, clean the level sensor rod and its float, however, paying particular attention to not damage it. Do not bend it and do not use it as a lever. It contains electronic material. Mechanical stresses, including moderate ones, can give rise to irreparable malfunctions.

When removing the floater to clean it and its plastic rod, be careful not to reverse the floater. The magnet side and O-ring have to face the person who is applying the kit.

6. Insert the new O-ring of the filter cap, place the new filter on the cap and close on the valve assembly paying attention to correctly screw it.
7. Insert the new valve assembly O-Ring.
8. Insert the valve components in the following order: spring and pilot in its spool, first insert the spring (insert the side without plastic of the pilot inside the spring) and lastly the diaphragm with its plastic guide. Ensure that diaphragm is correctly positioned.
9. Therefore, screw the valve assembly onto the condensate drain, tightening the 8 screws present with the following tightening torque values:

NED 4L: M3 Torx T10 = 0.5 Nm +0.2/-0.1 Nm, M6 Torx T30 = 6.5 Nm +2/-1 Nm

NED 6LC - NED 350L:M3 = 0.4 Nm ±15%, M6 = 8 Nm +2/-1 Nm

10. Replace the plastic ring (15) with the straight flow regulator (14).
11. The container chamber of the electronic board is sealed with a sealing gasket and must not be opened. All of the required connections can be accessed from the outside by electrical connectors.

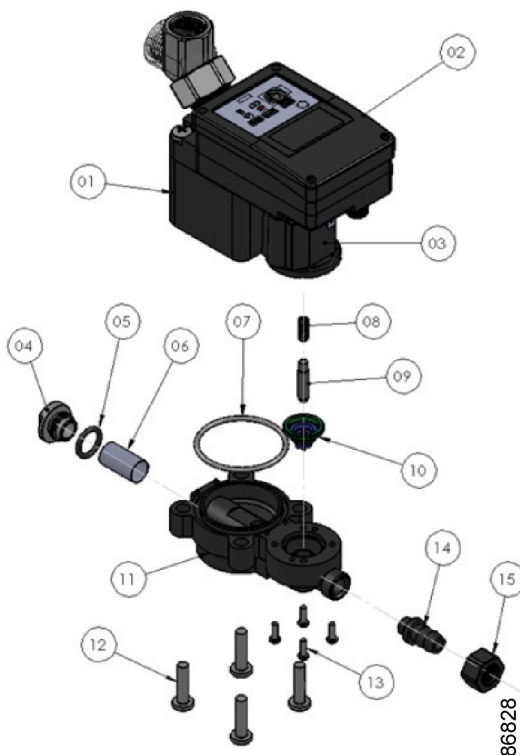

Figure 2: Exploded view

Reference	Description
01	Tank and level sensor
02	Electronic board
03	Solenoid valve
04	Filter cap
05	O-ring
06	Double mesh metallic filter
07	O-ring, valve assembly
08	Solenoid valve spring
09	Solenoid valve pilot
10	Diaphragm with the diaphragm guide
11	Valve assembly
12	M6x25 cross recessed screws
13	M3x10 cross recessed screws
14	Flow limiter
15	Plastic ring, flow limiter

6.2 Service kits

Description

Service kits are available, offering the benefit of genuine parts whilst at the same time keeping the maintenance budget low. The kits comprise all parts needed for servicing. Consult the Parts list for part numbers.

7 Problem solving

7.1 General causes

General

Malfunctioning can for example be caused by:

- Mistakes made during installation
- Pressures below the minimum pressure
- Excessive amount of condensate (overloading)
- Blocked or shut off outlet line
- Excessive amount of dirt particles
- Frozen piping

7.2 Faults and remedies



Danger: Before starting any maintenance or repairs, close the air outlet valve and press the test button on top of the electronic water drain to depressurize the air system.



Note: Apply all relevant instructions in section Safety precautions.

Problem solving

Error	Reason	Solution
The drain does not discharge condensate: the condensate drain does not indicate an alarm.	<p>There is no condensate in the condensate drain:</p> <ul style="list-style-type: none"> • The external shut-off valve between the discharge point and the condensate drain is closed. • The externally installed filter is clogged. • The condensate drain has not been installed correctly. There may be a siphon effect and/or air bubble upstream of the condensate drain. • The supply voltage is not powering the condensate drain. 	<ul style="list-style-type: none"> • Check the supply shut-off valve of the condensate drain. • Check the filter that might be installed externally in the condensate supply line. • Check the installation. • Ensure that the tube leading to the condensate drain is free. • Ensure that there is electrical power. • If the aforementioned points have been verified, the condensate drain is operating correctly. • Try a manual discharge with the TEST button.

Error	Reason	Solution
<p>The condensate drain discharges continuously.</p>	<p>Malfunction of the discharge valve diaphragm:</p> <ul style="list-style-type: none"> • The diaphragm is blocked by dirt. • The diaphragm is defective or worn out. 	<ul style="list-style-type: none"> • Clean the diaphragm. • Replace the diaphragm if necessary.
<p>The condensate drain is not discharging and cleaning routine 1 is active. (L2 slowly flashing).</p>	<p>The level sensor takes more than 20 sec to discharge the condensate and reach the minimum level:</p> <ul style="list-style-type: none"> • The double mesh integrated filter is clogged, dirty or defective. • The line at the condensate outlet is clogged. • The amount of condensate is too high. 	<ul style="list-style-type: none"> • Clean the integrated filter or substitute it if necessary. • Check that there are no obstructions in the line at the condensate outlet. • Try a manual discharge with the TEST button. • Ensure that the condensate drain is correctly sized for the application.
<p>The condensate drain does not discharge and cleaning routine 2 is active. (L2 quickly flashing). The drain is in an alarm situation.</p>	<p>The sensor has not managed to discharge for more than 2 minutes and has not reached the minimum level:</p> <ul style="list-style-type: none"> • The double mesh integrated filter is clogged, dirty or defective. • There is a great deal of dirt inside the condensate drain and on the plastic sensor rod/float. The float is blocked and/or descends with difficulty. • The diaphragm is clogged or blocked. • The tube at the condensate outlet is blocked. • There is an excessive quantity of condensate. 	<ul style="list-style-type: none"> • Clean integrated filter or replace it if necessary. • Clean the condensate drain internally, remove any possible dirt from the level sensor rod and float. Do not force, fold, or lever the level sensor rod. Any possible damage might compromise the condensate drain's operations. • Clean the diaphragm and if necessary replace it. • Check that there are no obstructions in the line at the condensate outlet. • Try a manual discharge with a TEST button. • Make sure that the condensate drain is correctly sized for the application.
<p>The condensate drain is in an alarm situation. (L2 is constantly lit).</p>	<p>There is an irreversible error in the condensate drain.</p>	<ul style="list-style-type: none"> • Try resetting the micro logic. • If the problem persists, substitute the condensate drain.

Error	Reason	Solution
<p>The manual discharge does not work correctly.</p>	<p>Possible clogging or malfunction of the condensate drain solenoid valve.</p> <ul style="list-style-type: none"> • The coil makes a “click” sound, but the discharge does not take place. The diaphragm is probably blocked or the filter is clogged and dirty. • The condensate drain only discharges air. The diaphragm is dirty or worn out. • The coil does not make any sound and the condensate drain does not discharge. The solenoid valve is defective. 	<ul style="list-style-type: none"> • Clean the diaphragm and if necessary, replace it. • Clean the integrated filter or replace it if necessary. • Substitute the condensate drain if necessary.

8 Optional equipment

8.1 Precautions for optional equipment



Danger: All responsibility for any damage or injury resulting from neglecting these precautions, or non-observance of the normal caution and care required for installation, operation, maintenance and repair, even if not expressly stated, will be disclaimed by the manufacturer.



Note: Some precautions are general and cover several machine types and equipment; hence some statements may not apply to your device.

Precautions

1. Make sure that all electrical wiring has been installed in compliance with the valid regulations.
2. Installation must always be performed by a qualified technician.
3. Installation must be carried out in compliance with the circuit diagrams and connection drawings provided.
4. The electronic drain valve, the feed line and the discharge line must be correctly insulated to prevent freezing and thus serious damage to the device or piping.
5. Do not switch off the heating if there is any likelihood of frost. There may still be condensate left inside the Electronic Water Drain.

8.2 Heater

C683 Heater kit

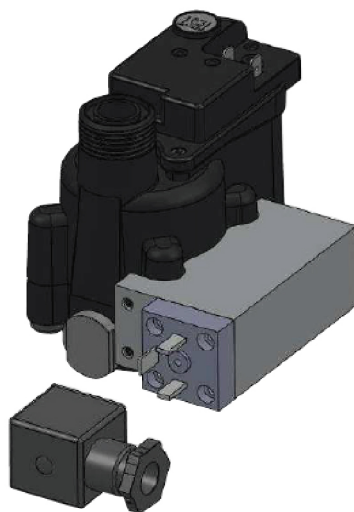

86829

Components

- Heater kit.
- Industrial connector type A, 2P+T field attachable.
- Screw M3x10 (x2).

Features

- Aluminum body fitted for NED 6LC plastic receiver.
- Cartridge heaters Hotrod Ø10x40 mm, 230 V – 100 W.
- Multipurpose Thermostats N/C 15 °C ±3 °C.
- Industrial connector type A 2P+T, EN17301-803 (ex DIN43650) with screw.
- Appliance connector type A 2P+T (ex DIN43650) with square seal.

Assembly

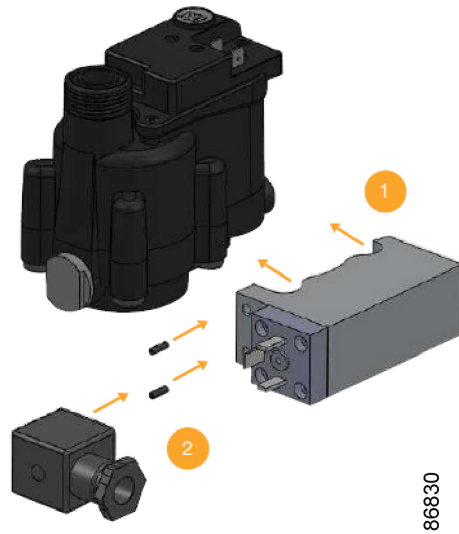

1. Fix the body on the plastic tank (as shown on the picture) using the 2 screws.
2. Close the square connector type A to the heater adapter, using its M3 screw.

C685 Heater kit

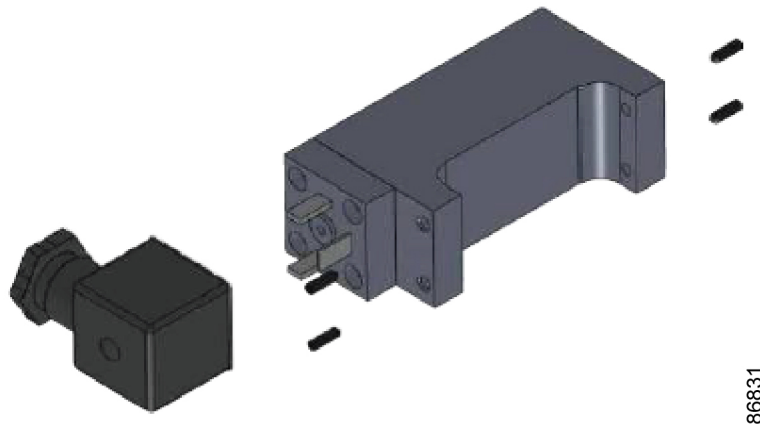

Components

- Heater kit.
- Industrial connector type A, 2P+T field attachable.
- Screw M3x10 (x4).

Features

- Aluminum body fitted for square tank.

- Cartridge heaters HOTROD Ø10x40mm, 230V – 100W.
- Multipurpose Thermostats N/C 15°C ±3°C.
- Industrial connector type A 2P+T, EN17301-803 (ex DIN43650) with screw.
- Appliance connector type A 2P+T (ex DIN43650) with square seal.

Assembly

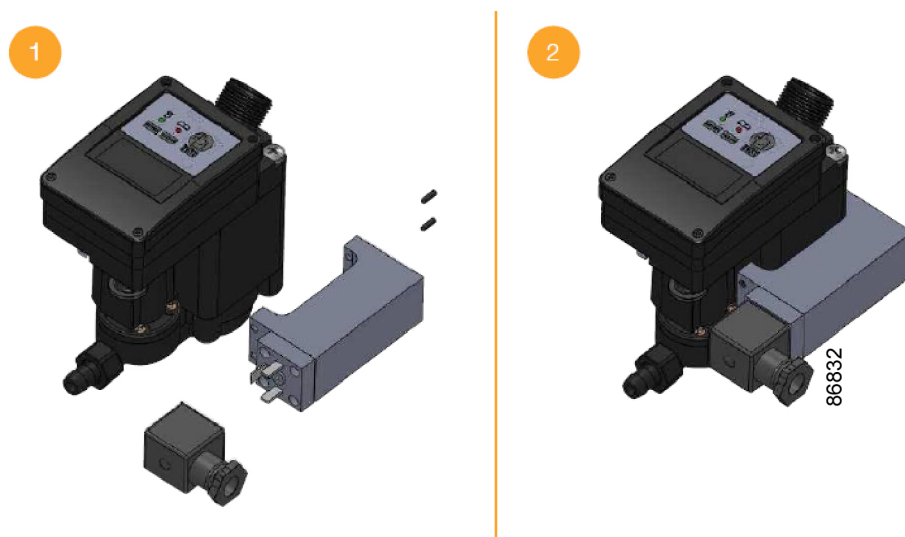

1. Fix the body on the plastic tank (as shown on the picture) using the 4 screws.
2. Close the square connector type A to the heater adapter, using its M3 screw.

C686 Heater kit

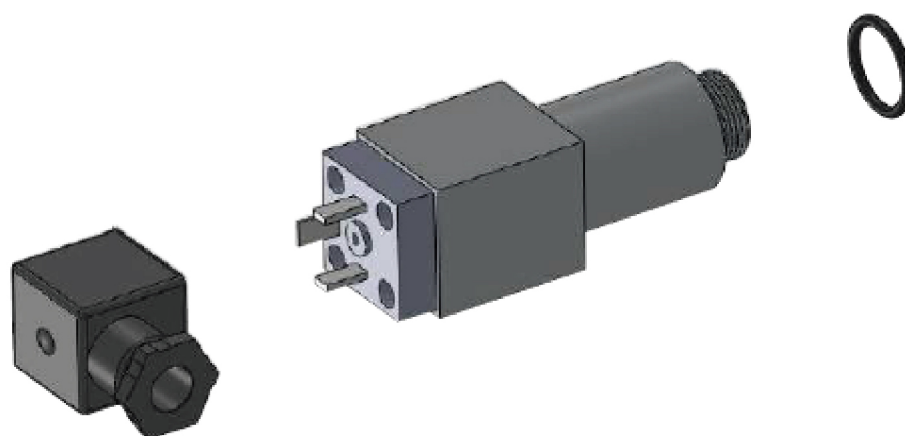

Components

- Heater kit with O-ring.
- Industrial connector type A, 2P+T field attachable.

Features

- Aluminum body with thread G1/2”M and O-Ring.
- Cartridge heaters HOTROD Ø 10x40 mm, 230 V – 100 W.
- Multipurpose Thermostats N/C 15°C ±3°C.

- Industrial connector type A 2P+T, EN17301-803 (ex DIN43650) with screw.
- Appliance connector type A 2P+T (ex DIN43650) with square seal.

Assembly

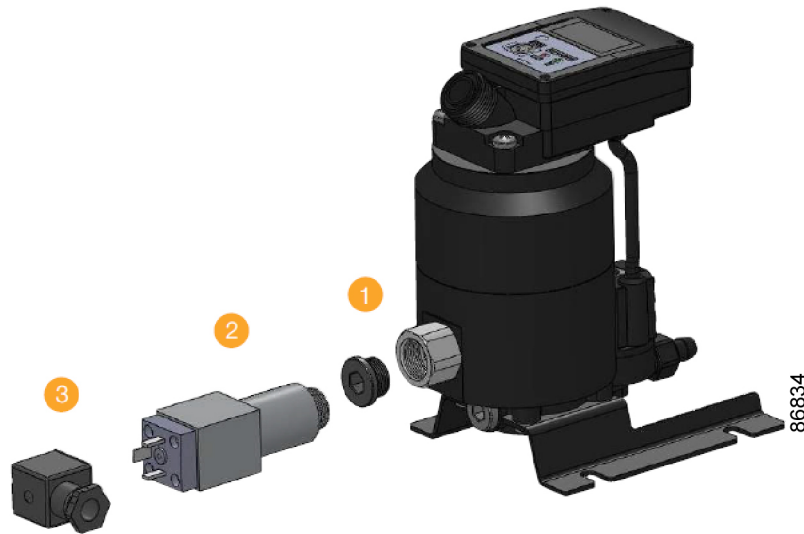

1. Remove the threaded cap with key CH10 of the adapter of the secondary inlet.
2. Screw the aluminum heater G1/2" M on the adapter of the vessel G1/2" F.
3. Close the Square connector type A to the heater adapter, using its M3 screw.

Check the presence of the O-Ring before screw the heater.

9 Technical data

9.1 Reference conditions and limitations

Reference conditions

Reference ambient temperature	°C	20
Reference ambient temperature	°F	68
Reference relative humidity	%	60

Limits

Minimum temperature	°C	1
Minimum temperature	°F	33.8
Maximum temperature	°C	60
Maximum temperature	°F	140
Minimum working pressure	bar	0.2
Minimum working pressure	psi	3
Maximum working pressure	bar	16
Maximum working pressure	psi	232

9.2 Electronic water drain data

		NED 4L	NED 6LC	NED 8LC	NED 16LC
Nominal flow	l/s	50	105	125	250
	cfm	106	222	265	530
Nominal drain	l/h	2	3	5	10
	cfh	0.07	0.12	0.18	0.35
Maximum drain	l/h	5	10	15	20
	cfh	0.18	0.35	0.53	0.71
Maximum compressor capacity when used as compressor drain	l/s	50	105	125	250
	cfm	106	222	265	530
Maximum dryer capacity when used as dryer drain	l/s	100	210	250	500
	cfm	212	445	530	1059
Maximum filter capacity when used as filter drain	l/s	500	1050	1250	2500
	cfm	1059	2225	2649	5297
Weight	kg	0.4	0.5	0.6	0.7
	lb	0.88	1.10	1.32	1.54
Type of condensate		Suitable for all condensate			
Collector material		Aluminum			

		NED 4L	NED 6LC	NED 8LC	NED 16LC
Collector volume	l	0.06	0.08	0.09	0.11
	ft ³	0.002	0.003	0.003	0.004
Condensate inlet	G-NPT	1x G3/4" M	1x G1/2" F	1x G1/2" F + 1x G3/4" M - G1/2" F	
Condensate outlet (hose)	mm	12			
	inch	0.47			
Supply voltage	V	See data plate, ± 10 %			
Frequency	Hz	50-60			
Isolation class		IP 65			
Maximum power consumption	VA	10			
Alarm contact		No alarm	Contact NC/NO: 240V Ac max - 1A / 30V Dc max - 1A		
Electric connection		EN 175301-803 Type B			
Alarm connection		-	M12 Code A 4 Poles		
Fuse	A	1			
Maximum rise of outlet line	m	5			
	ft	16.4			

		NED 40LC	NED 160LC	NED 350L
Nominal flow	l/s	500	2667	5000
	cfm	1059	5650	10594
Nominal drain	l/h	20	90	200
	cfh	0.71	3.18	7.06
Maximum drain	l/h	35	150	350
	cfh	1.24	5.30	12.36
Maximum compressor capacity when used as compressor drain	l/s	500	2667	5000
	cfm	1059	5650	10594
Maximum dryer capacity when used as dryer drain	l/s	1000	5333	10000
	cfm	2119	11301	21189
Maximum filter capacity when used as filter drain	l/s	5000	26667	50000
	cfm	10594	56503	105944
Weight	kg	1.2	1.8	3.45
	lb	2.65	3.97	7.61
Type of condensate		Suitable for all condensate		
Collector material		Aluminum		
Collector volume	l	0.22	0.5	1.5
	ft ³	0.008	0.018	0.053
Condensate inlet	G-NPT	1x G1/2" F + 1x G3/4" M - G1/2" F		2x G1/2" F + 1x G3/4" F
Condensate outlet (hose)	mm	12		
	inch	0.47		
Supply voltage	V	See data plate, ± 10 %		
Frequency	Hz	50-60		
Isolation class		IP 65		

		NED 40LC	NED 160LC	NED 350L
Maximum power consumption	VA	10		
Alarm contact		Contact NC/NO: 240V Ac max - 1A / 30V Dc max - 1A		
Electric connection		EN 175301-803 Type B		
Alarm connection		M12 Code A 4 Poles		
Fuse	A	1		
Maximum rise of outlet line	m	5		
	ft	16.4		

10 Pressure equipment directives

Components subject to 2014/68/EU Pressure Equipment Directive

The units conform to Article 4.3.

11 Declaration of conformity

Insert logo here

EU DECLARATION OF CONFORMITY

2 We, (1) declare under our sole responsibility, that the product
 3 Machine name :
 4 Machine type :
 5 Serial number :

6 Which falls under the provisions of article 12.2 of the EC Directive 2006/42/EC on the approximation of the laws of the Member States relating to machinery, is in conformity with the relevant Essential Health and Safety Requirements of this directive.

The machinery complies also with the requirements of the following directives and their amendments as indicated.

	Directive on the approximation of laws of the Member States relating to	Harmonized and/or Technical Standards used	Att'mnt
a	(2)	(3)	
b			X
c			
d			X
e			
f			
g			X

8a The harmonized and the technical standards used are identified in the attachments hereafter

8b <1> is authorized to compile the technical file.

	Conformity of the specification to the directives	Conformity of the product to the specification and by implication to the directives
11	Issued by	Manufacturing
12	Engineering	
13	Name	
14	Signature	
15	Date	
16	Place	
17		

Figure 3: Typical example of a Declaration of Conformity document

- (1) Contact address:
Atlas Copco Airpower n.v.
P.O. Box 100
B-2610 Wilrijk (Antwerp)
Belgium
- (2) Applicable directives
- (3) Standards used

On the Declaration of Conformity / Declaration by the Manufacturer, the harmonized and/or other standards that have been used for the design are shown and/or referred to.

The Declaration of Conformity / Declaration by the Manufacturer is part of the documentation that is supplied with this device.

Experience. Customer. Service.

