

μChiller

Controller for chiller / Heat Pump



Controller manual

Rel.: 1.0

22/01/2021

Manual code:

99980501



EN

Revision History

Release	Date	Action
1.0	22/01/2021	First release

For Technical Support, please contact the company:

--	--

IMPORTANT



The products described in this manual, in relation to its advanced level of technology, requires setup / configuration / programming / commissioning to be able to operate in the best possible way for the specific application. The failure to complete such operations, which are required/indicated in the user manual, may cause the final product to malfunction; the manufacturer accepts no liability in such cases.

Only qualified personnel may install or carry out technical service on the product.

The customer must only use the product in the manner described in the documentation relating to the product.

- Do not attempt to open the device in any way other than described in the manual.
- Do not drop, hit or shake the device, as the internal circuits and mechanisms may be irreparably damaged.
- Do not use corrosive chemicals, solvents or aggressive detergents to clean the device.
- Do not use the product for applications other than those specified in the technical manual.

DISPOSAL



INFORMATION FOR USERS ON THE CORRECT HANDLING OF WASTE ELECTRICAL AND ELECTRONIC EQUIPMENT (WEEE).

The product is made up of metal parts and plastic parts. In reference to European Union directive 2002/96/EC issued on 27 January 2003 and related national legislation, please note that:

- WEEE cannot be disposed of as municipal waste and such waste must be collected and disposed of separately;
- the public or private waste collection systems defined by local legislation must be used. In addition, the equipment can be returned to the distributor at the end of its working life when buying new equipment;
- the equipment may contain hazardous substances: the improper use or incorrect disposal of such may have negative effects on human health and on the environment;
- the symbol (crossed- out wheeled bin) shown on the product or on the packaging and on the instruction sheet indicates that the equipment has been introduced onto the market after 13 August 2005 and that it must be disposed of separately;
- in the event of illegal disposal of electrical and electronic waste, the penalties are specified by local waste disposal legislation.

Key to the symbols:



Important: to bring critical issues to the attention of those using the product.



Note: to focus attention on important topics; in particular the practical application of the various product functions.

Table of contents

1.	Introduction	7
1.1	Models.....	7
2.	Functional diagrams.....	8
2.1	Chillers, On/Off compressors and thermostatic expansion valve	8
2.2	Chillers, On/Off compressors with free cooling and thermostatic expansion valve.....	10
2.3	Chillers/ heat pumps, On/Off compressors and bipolar ExV expansion valve	12
2.4	Chillers/water to water heat pumps, On/Off compressors and bipolar ExV expansion valve.....	14
2.5	Chillers, On/Off compressors and unipolar ExV expansion valve	16
3.	Initial Configuration	18
3.1	APPLICA App.....	18
3.1.1	Applica: Date & hour settings	18
3.1.2	Unit set-up parameter list.....	19
3.1.3	mCH2 parameters	20
3.2	APPLICA Desktop.....	21
3.2.1	Preparing for operation	21
3.2.2	Applica Desktop: date and time setting.....	22
4.	User Interface	23
4.1	Introduction	23
4.2	User Terminal	23
4.2.1	Keypad	24
4.2.2	Icons.....	24
4.3	Standard display.....	24
4.3.1	Dashboard.....	25
4.3.2	Direct access functions	26
4.3.3	Programming mode	27
4.3.4	Programming menu	28
5.	Functions.....	29
5.1	Temperature control	29
5.1.1	PID Control.....	29
5.1.2	Proportional control	30
5.1.3	Set point compensation.....	31
5.1.4	Request from BMS	32
5.1.5	High evaporator outlet temperature alarm.....	32
5.2	User pump.....	32
5.2.1	Cyclical pump activation during standby	34
5.3	Frost protection control	35
5.3.1	Frost protection alarm	35

5.3.2	Frost protection threshold with glide (R407C)	37
5.3.3	Frost protection alarm with water temperature	37
5.3.4	Frost prevention	37
5.3.5	Frost prevention with the unit OFF.....	38
5.4	Compressor rotation	38
5.4.1	Frost prevention with the unit OFF.....	38
5.4.2	Capacity distribution.....	38
5.4.3	Rotation due to alarm.....	39
5.4.4	Force rotation (destabilisation)	39
5.5	Compressor management.....	40
5.5.1	Compressors with capacity control (Legacy model only)	40
5.6	Compressor alarms	41
5.7	Expansion valve driver.....	41
5.8	Control of the expansion valve.....	42
5.9	Source pump	42
5.10	Source fans	43
5.10.1	Modulating / On-Off fans.....	43
5.10.2	Control in chiller mode	44
5.10.3	Control in heat pump mode.....	45
5.10.4	“Low noise” function	46
5.10.5	Fan anti-blocking function	46
5.11	Free cooling.....	46
5.12	Types of free cooling	47
5.12.1	Condensing unit with common air circuit.....	47
5.12.2	Air-cooled condensing unit with separate air circuit.....	48
5.12.3	Water-cooled condensing unit	49
5.13	Free cooling functions.....	50
5.13.1	Dynamic control gain	50
5.13.2	Effectiveness control.....	51
5.13.3	Valve anti-block management	51
5.14	Defrost.....	51
5.14.1	Defrost procedure.....	52
5.14.2	Defrost with fans.....	55
5.14.3	Sliding defrost	56
5.14.4	Defrost synchronisation.....	56
5.15	4-way valve management	57
5.16	Condensing unit management	57
6.	PARAMETER TABLE	60
6.1	System.....	60
6.2	Compressor	61



6.2.1	Inverter compressor	62
6.3	Electronic valve	63
6.4	Source.....	63
6.5	Input /output configuration	64
6.6	mCH2 Parameters (Legacy model only)	65
6.7	BMS port	66
6.8	Password	66
6.9	Dashboard values	67
6.10	Settings.....	68
7.	Supervisor table	69
7.1	Coil Status.....	69
7.2	Input Status	70
7.3	Holding Registers.....	72
7.4	Input register.....	76
8.	Alarms and signals	78
8.1	Active alarms	78
8.2	Active alarms list	80
9.	Technical specifications	82
9.1	Connector/cable table.....	84

1. Introduction

μChiller is the Carel solution for complete management of air/water and water/water chillers and heat pumps, and condensing units. The solution also allows the field replacement of μchiller2 and μchiller2 SE with the new product (hereinafter called the **Legacy** model).

The maximum configuration manages 2 compressors per circuit, up to a maximum of 2 circuits (using an expansion card for circuit 2). The distinctive element of μChiller is complete control of high-efficiency units through integrated management of electronic expansion valves (ExV), thus ensuring greater compressor protection and reliability and a high-efficiency unit. The user terminal allows wireless connectivity with mobile devices and is built-in on the panel mounted models, or sold separately on DIN rail mounted models. CAREL's "APPLICA" app, available on Google Play for the Android operating system, makes it easier to configure parameters and commission the unit in the field.

1.1 Models

Models P/N	Assembly	Connectivity	Compressor management	Notes	Electronic expansion valve management
UCHBP00000190	panel	NFC	On/Off	Standard version	bipolar: with EVD Evolution driver
UCHBP00000200	panel	NFC, Bluetooth (BLE)	On/Off	Standard version	bipolar: with EVD Evolution driver
UCHBD00001230	DIN rail	-	On/Off	Standard version	bipolar: with EVD Evolution driver
UCHBDE0001150	DIN rail	-	On/Off	Enhanced version	unipolar: built-in; bipolar with external EVD Evolution driver
UCHBDH0001150	DIN rail	-	On/Off and BLDC	-	bipolar: with external EVD Evolution driver
UCHBE00001230 2nd circuit expansion	DIN rail	-	On/Off and BLDC		unipolar: built-in; bipolar with external EVD Evolution driver
UCHBE00001150 2nd circuit expansion	DIN rail	-	On/Off and BLDC	-	unipolar: built-in; bipolar: with external EVD Evolution driver
UCHBP000X0190	panel	NFC	On/Off	Legacy version	bipolar: with EVD Evolution driver
UCHBP000X0200	NFC, Bluetooth	NFC, Bluetooth	On/Off	Legacy version	bipolar: with EVD Evolution driver
UCHBP000X0230	DIN rail	-	On/Off	Legacy version	bipolar: with EVD Evolution driver

2. Functional diagrams

2.1 Chillers, On/Off compressors and thermostatic expansion valve



Important: The black lines refer to the electrical connections, the grey lines the serial connections between controller and options (I/O expansion for the second circuit, EVD and EVO).

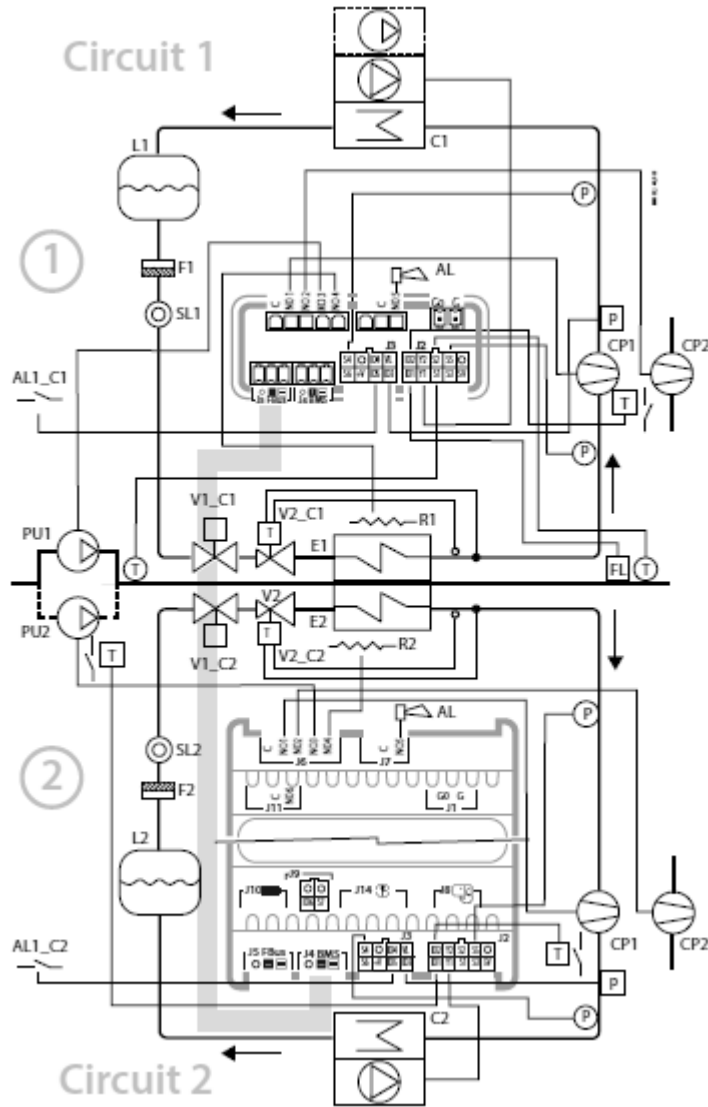

Ref.	Description	Ref.	Description	Ref.	Description
C1/C2	Condenser 1/2	PU1/2	User pump 1/2	AL1_C1/2	Remote alarm circuit 1/2
E1/E2	Evaporator 1/2	L1/2	Liquid receiver 1/2	CP1/2	Compressor 1/2
V1_C1	Solenoid valve circuit 1	SL1/2	Liquid sight glass 1/2	R1/2	Frost protection heater 1/2
V1_C2	Solenoid valve circuit 2	F1/2	Filter-drier 1/2	P	Pressure probe/pressure switch
V2_C1	Thermostatic expansion valve circuit 1	FL	Flow switch	T	Temperature probe / thermostat
V2_C2	Thermostatic expansion valve circuit 2	AL	Alarm		

Analogue inputs – Master Circuit 1

Ref.	Description	Type	Configuration parameters
S1	Return temperature from user	NTC	Hc31
S2	Delivery temperature to user	NTC	Hc32
S3	Not present	-	Hc00
S4	Condensing pressure	0-5V	Hc34; C040; C041; C042
S5	Evaporation pressure	0-5V	Hc35; C037; C038; C039
S6	Not present	-	Hc03; U025; U026; U027

Analogue inputs – Slave Circuit 2

Ref.	Description	Type	Configuration parameters
S1	Not present	-	Hc41
S2	Not present	-	Hc42
S3	Not present	-	Hc43
S4	Condensing pressure	0-5V	Hc44; C040; C041; C042
S5	Evaporation pressure	0-5V	Hc45; C037; C038; C039
S6	Not present	-	Hc05; U025; U026; U027



Notice: the discharge temperature probe is automatically assigned type NTC-HT

Digital inputs – Master Circuit 1

Ref.	Description	Configuration parameters
ID1	User pump flow switch	Hc14; U060
ID2	Compressor 1 overload	Hc15; C035
ID3	High pressure switch	C034
ID4	Not present	Hc06; C035; U059; U058; U062; U057; U061
ID5	Remote alarm	Hc07; C035; U059; U058; U062; U057; U061

Digital inputs – Slave Circuit 2

Ref.	Description	Configuration parameters
ID1	Pump 2 overload	Hc16; U061
ID2	Compressor 1 overload	Hc17; C035
ID3	High pressure switch	C034
ID4	Not present	Hc09; C035; U059; U058; U062; U057; U061
ID5	Not present	Hc10;
ID6	Not present	Hc11

Digital outputs – Master Circuit 1

Ref.	Description	Configuration parameters
C-NO1	Compressor 1	Hc51; C036
C-NO2	Compressor 2	Hc52; C036
C-NO3	User pump 1	Hc53; U063
C-NO4	Frost protection heater (*)	Hc54; U066; S063; U065
C5-NO5	Alarm	Hc55; U064

Digital outputs – Slave Circuit 2

Ref.	Description	Configuration parameters
C-NO1	Compressor 1	Hc61; C036
C-NO2	Compressor 2	Hc62; C036
C-NO3	User pump 1	Hc63; U063
C-NO4	Frost protection heater (*)	Hc64; U066; S063; U065
C5-NO5	Not used	Hc65; U064
C6-NO6	Not used	Hc66



Notice: (*) the configuration of the output depends on the type of unit: heat pump (reverse-cycle) => reversing valve; Chiller with free cooling (master only) => FC valve; otherwise => Frost protection heater.

Analogue outputs – Master Circuit 1

Ref.	Description	Type	Configuration parameters	Notes
Y1	Modulating/On-Off fan	0-10V	Hc71	FCS1*0/CONVONOFF
Y2	Not used	0-10V	Hc72	

Analogue outputs – Slave Circuit 2

Ref.	Description	Type	Configuration parameters	Notes
Y1	Modulating/On-Off fan	0-10V	Hc81	FCS1*0/CONVONOFF
Y2	Not used	0-10V	Hc82	

2.2 Chillers, On/Off compressors with free cooling and thermostatic expansion valve



Important: The black lines refer to the electrical connections, the grey lines the serial connections between controller and options (I/O expansion for the second circuit, EVD and EVO).

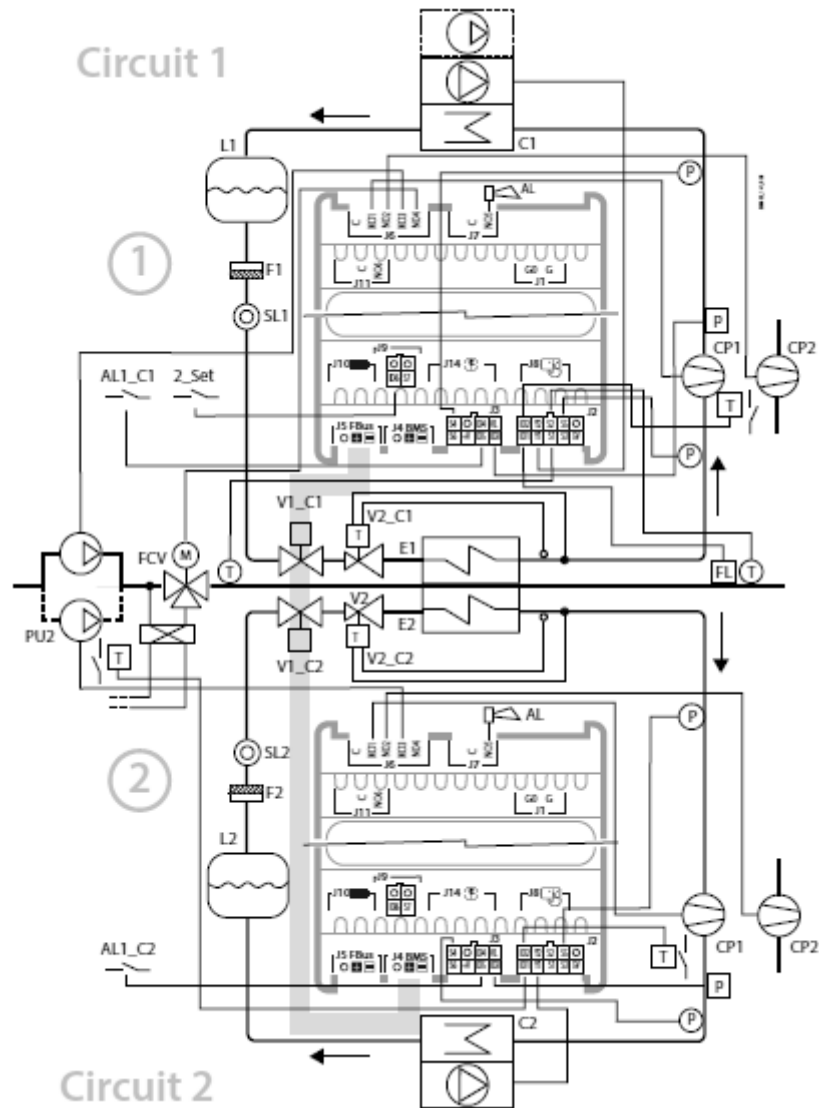

Ref.	Description	Ref.	Description	Ref.	Description
C1/C2	Condenser 1/2	FCV	Free cooling valve	P	Pressure probe/pressure switch
E1/E2	Evaporator 1/2	SL1/2	Liquid sight glass 1/2	T	Temperature probe / thermostat
V1_C1	Solenoid valve circuit 1	F1/2	Filter-drier 1/2	AL	Alarm
V1_C2	Solenoid valve circuit 2	FL	Flow switch	AL1_C1/2	Remote alarm circuit 1/2
V2_C1	Thermostatic expansion valve circuit 1	CP1/2	Compressor 1/2	2_Set	2 nd set point
V2_C2	Thermostatic expansion valve circuit 2	PU1/2	User pump 1/2	L1/2	Liquid receiver 1/2

Analogue inputs – Master Circuit 1

Ref.	Description	Type	Configuration parameters
S1	Return temperature from user	NTC	Hc31
S2	Delivery temperature to user	NTC	Hc32
S3	Not present	-	Hc00
S4	Condensing pressure	0-5V	Hc34; C040; C041; C042
S5	Evaporation pressure	0-5V	Hc35; C037; C038; C039
S6	Not present	-	Hc03; U025; U026; U027

Analogue inputs – Slave Circuit 1

Ref.	Description	Type	Configuration parameters
S1	Not present	-	Hc41
S2	Not present	-	Hc42
S3	Not present	-	Hc43
S4	Condensing pressure	0-5V	Hc44; C040; C041; C042
S5	Evaporation pressure	0-5V	Hc45; C037; C038; C039
S6	Not present	-	Hc05; U025; U026; U027



Notice: the discharge temperature probe is automatically assigned type NTC-HT

Digital inputs – Master Circuit 1

Ref.	Description	Configuration parameters
ID1	User pump flow switch	Hc14; U060
ID2	Compressor 1 overload	Hc15; C035
ID3	High pressure switch	C034
ID4	Not present	Hc06; C035; U059; U058; U062; U057; U061
ID5	Not present	Hc07; C035; U059; U058; U062; U057; U061
ID6	Not present	Hc08; C035; U059; U058; U062; U057; U061

Digital inputs – Slave Circuit 2

Ref.	Description	Configuration parameters
ID1	Pump 2 overload	Hc16; U061
ID2	Compressor 1 overload	Hc17; C035
ID3	High pressure switch	C034
ID4	Not present	Hc09; C035; U059; U058; U062; U057; U061
ID5	Remote alarm	Hc10
ID6	Not present	Hc11

Digital outputs – Master Circuit 1

Ref.	Description	Configuration param.s
C-NO1	Compressor 1	Hc51; C036
C-NO2	Compressor 2	Hc52; C036
C-NO3	User pump 1	Hc53; U063
C-NO4	Free cooling valve (*)	Hc54; U066; S063; U065
C5-NO5	Alarm	Hc55; U064
C6-NO6	Not used	Hc56

Digital outputs – Slave Circuit 2

Ref.	Description	Configuration param.s
C-NO1	Compressor 1	Hc61; C036
C-NO2	Compressor 2	Hc62; C036
C-NO3	User pump 1	Hc63; U063
C-NO4	Not used	Hc64
C5-NO5	Alarm	Hc65
C6-NO6	Not used	Hc66



Notice: (*) the configuration of the output depends on the type of unit: heat pump (reverse-cycle) => reversing valve; Chiller with free cooling (master only) => FC valve; otherwise => Frost protection heater.

Analogue outputs – Master Circuit 1

Ref.	Description	Type	Configuration parameters	Notes
Y1	Modulating/On-Off fan	0-10V	Hc71	FCS1*0/CONVONOFF
Y2	Not used	0-10V	Hc72	

Analogue outputs – Slave Circuit 2

Ref.	Description	Type	Configuration parameters	Notes
Y1	Modulating/On-Off fan	0-10V	Hc81	FCS1*0/CONVONOFF
Y2	Not used	0-10V	Hc82	

2.3 Chillers/ heat pumps, On/Off compressors and bipolar ExV expansion valve



Important: The black lines refer to the electrical connections, the grey lines the serial connections between controller and options (I/O expansion for the second circuit, EVD and EVO).

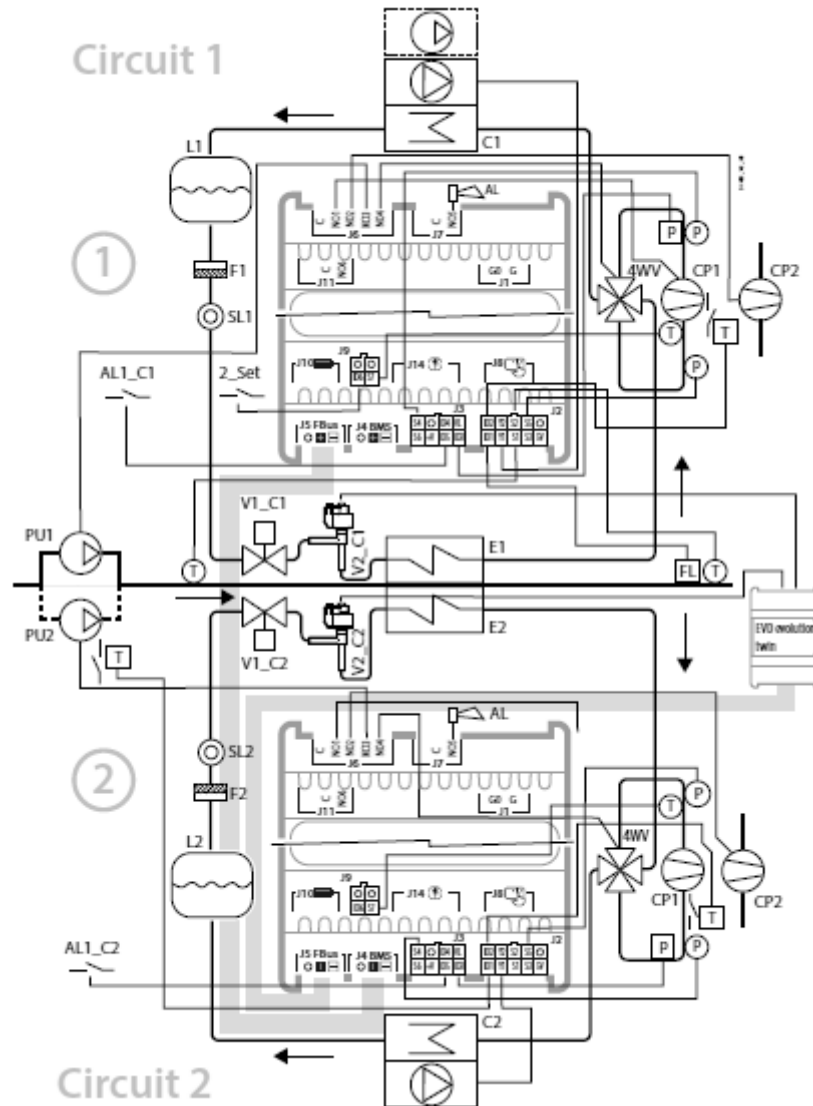

Ref.	Description	Ref.	Description	Ref.	Description
C1/C2	Condenser 1/2	SL1/2	Liquid sight glass 1/2	4WV	Reversing valve
E1/E2	Evaporator 1/2	F1/2	Filter-drier 1/2	P	Pressure probe/pressure switch
V1_C1	Solenoid valve circuit 1	FL	Flow switch	T	Temperature probe / thermostat
V1_C2	Solenoid valve circuit 2	CP1/2	Compressor 1/2	PU1/2	User pump 1/2
V2_C1	Electronic expansion valve circuit 1	L1/2	Liquid receiver 1/2	AL	Alarm
V2_C2	Electronic expansion valve circuit 2	AL1_C1/2	Remote alarm circuit 1/2	2_Set	2 nd set point

Analogue inputs – Master Circuit 1

Ref.	Description	Type	Configuration parameters
S1	Return temperature from user	NTC	Hc31
S2	Delivery temperature to user	NTC	Hc32
S3	Not present	-	Hc00
S4	Condensing pressure	0-5V	Hc34; C040; C041; C042
S5	Evaporation pressure	0-5V	Hc35; C037; C038; C039
S6	Not present	-	Hc03; U025; U026; U027
S7	Suction temperature	NTC	Hc04

Analogue inputs – Slave Circuit 2

Ref.	Description	Type	Configuration parameters
S1	Not present	-	Hc41
S2	Not present	-	Hc42
S3	Not present	-	Hc43
S4	Condensing pressure	0-5V	Hc44; C040; C041; C042
S5	Evaporation pressure	0-5V	Hc45; C037; C038; C039
S6	Not present	-	Hc05; U025; U026; U027
S7	Suction temperature	NTC	Hc47



Notice: the discharge temperature probe is automatically assigned type NTC-HT

Digital inputs – Master Circuit 1

Ref.	Description	Configuration parameters
ID1	User pump flow switch	Hc14; U060
ID2	Compressor 1 overload	Hc15; C035
ID3	High pressure switch	C034
ID4	Not present	Hc06; C035; U059; U058; U062; U057; U061
ID5	Remote alarm	Hc07; C035; U059; U058; U062; U057; U061
ID6	2 nd set point	Hc08; C035; U059; U058; U062; U057; U061

Digital inputs – Slave Circuit 2

Ref.	Description	Configuration parameters
ID1	Pump 2 overload	Hc16; U061
ID2	Compressor 1 overload	Hc17; C035
ID3	High pressure switch	C034
ID4	Not used	Hc09; C035; U059; U058; U062; U057; U061
ID5	Not used	Hc10; C035; U059; U058; U062; U057; U061
ID6	Not used	Hc11

Digital outputs – Master Circuit 1

Digital outputs – Slave Circuit 2

Ref.	Description	Configuration paramet.	Ref.	Description	Configuration paramet.
C-NO1	Compressor 1	Hc51; C036	C-NO1	Compressor 1	Hc61; C036
C-NO2	Compressor 2	Hc52; C036	C-NO2	Compressor 2	Hc62; C036
C-NO3	User pump 1	Hc53; U063	C-NO3	User pump 2	Hc63; U063
C-NO4	Reversing valve	Hc54; U066; S063; U065	C-NO4	Reversing valve	Hc64; U66; S063; U065
C5-NO5	Alarm	Hc55; U064	C5-NO5	Alarm	Hc65
C6-NO6	Not used	Hc56	C6-NO6	Not used	Hc66



Notice: (*) the configuration of the output depends on the type of unit: heat pump (reverse-cycle) => reversing valve; Chiller with free cooling (master only) => FC valve; otherwise => Frost protection heater.

Analogue outputs – Master Circuit 1

Ref.	Description	Type	Configuration parameters	Notes
Y1	Modulating/On-Off fan	0-10V	Hc71	FCS1*0/CONVONOFF
Y2	Not used	0-10V	Hc72	

Analogue outputs – Slave Circuit 2

Ref.	Description	Type	Configuration parameters	Notes
Y1	Modulating/On-Off fan	0-10V	Hc81	FCS1*0/CONVONOFF
Y2	Not used	0-10V	Hc82	

2.4 Chillers/water to water heat pumps, On/Off compressors and bipolar ExV expansion valve



Important: The black lines refer to the electrical connections, the grey lines the serial connections between controller and options (I/O expansion for the second circuit, EVD and EVO).

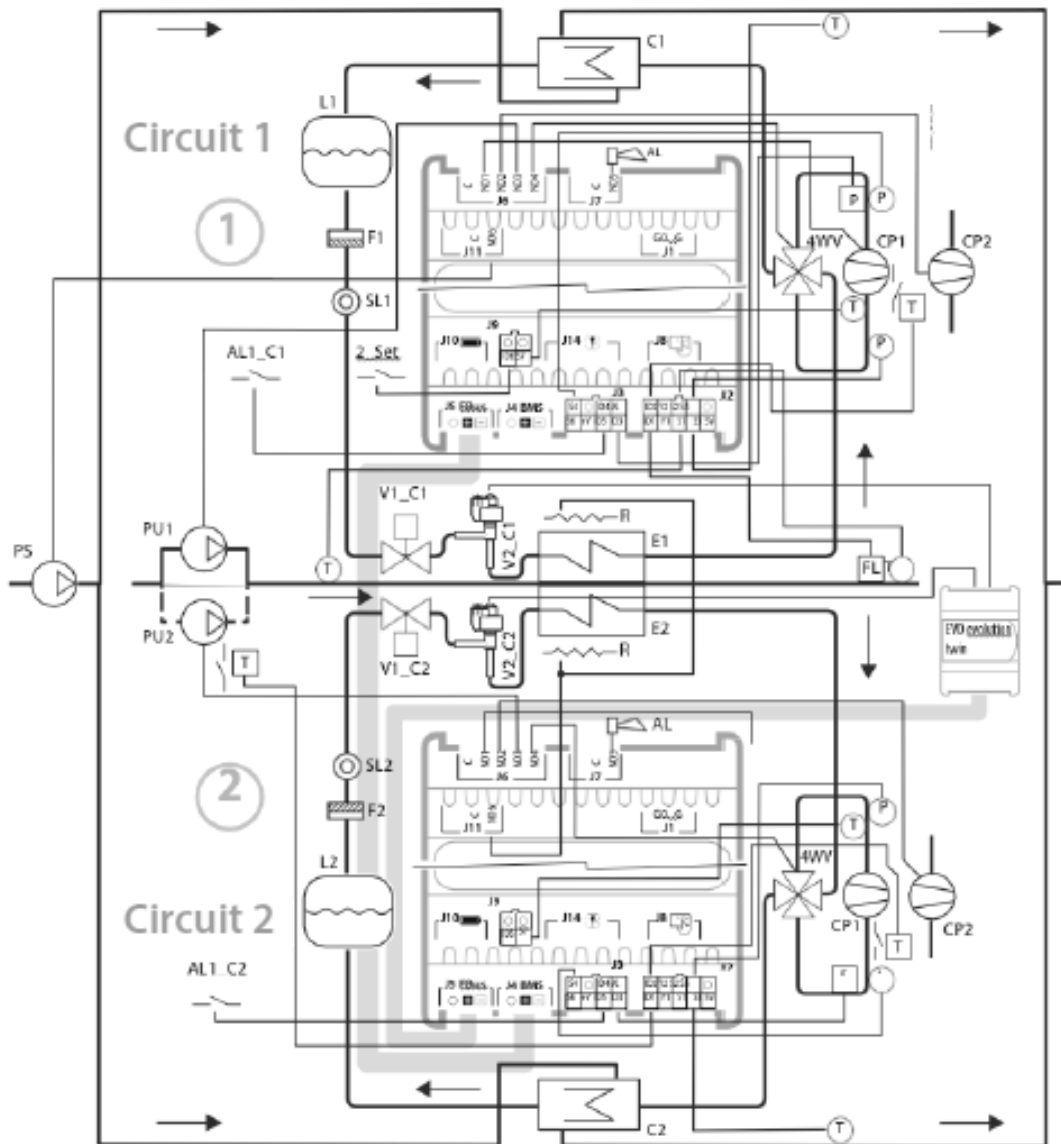

Ref.	Description	Ref.	Description	Ref.	Description
C1/C2	Condenser 1/2	SL1/2	Liquid sight glass 1/2	4WV	Reversing valve
E1/E2	Evaporator 1/2	F1/2	Filter-drier 1/2	P	Pressure probe/pressure switch
V1_C1	Solenoid valve circuit 1	FL	Flow switch	AL	Alarm
V1_C2	Solenoid valve circuit 2	CP1/2	Compressor 1/2	T	Temperature probe / thermostat
V2_C1	Electronic expansion valve circuit 1	PU1/2	User pump 1/2	L1/2	Liquid receiver 1/2
V2_C2	Electronic expansion valve circuit 2	PS	Source pump	AL1_C1/2	Remote alarm circuit 1/2
R1/2	Frost protection heater	2_Set	2 nd set point		

Analogue inputs – Master Circuit 1

Ref.	Description	Type	Configuration parameters
S1	Return temperature from user	NTC	Hc31
S2	Delivery temperature to user	NTC	Hc32
S3	Source water delivery temperature	NTC	Hc00
S4	Condensing pressure	0-5V	Hc34; C040; C041; C042
S5	Evaporation pressure	0-5V	Hc35; C037; C038; C039
S6	Not present	-	Hc03; U025; U026; U027
S7	Suction temperature	NTC	Hc04

Analogue inputs – Slave Circuit 2

Ref.	Description	Type	Configuration parameters
S1	Not present	-	Hc41
S2	Not present	-	Hc42
S3	Source water delivery temperature	NTC	Hc00
S4	Condensing pressure	0-5V	Hc44; C040; C041; C042
S5	Evaporation pressure	0-5V	Hc45; C037; C038; C039
S6	Not present	-	Hc05; U025; U026; U027
S7	Suction temperature	NTC	Hc47



Notice: the discharge temperature probe is automatically assigned type NTC-HT

Digital inputs – Master Circuit 1

Ref.	Description	Configuration parameters
ID1	User pump flow switch	Hc14; U060
ID2	Compressor 1 overload	Hc15; C035
ID3	High pressure switch	C034
ID4	Not present	Hc06; C035; U059; U058; U062; U057; U061
ID5	Remote alarm	Hc07; C035; U059; U058; U062; U057; U061
ID6	2 nd set point	Hc08; C035; U059; U058; U062; U057; U061

Digital inputs – Slave Circuit 2

Ref.	Description	Configuration parameters
ID1	Pump 2 overload	Hc16; U061
ID2	Compressor 1 overload	Hc17; C035
ID3	High pressure switch	C034
ID4	Not present	Hc09; C035; U059; U058; U062; U057; U061
ID5	Not present	Hc10; C035; U059; U058; U062; U057; U061
ID6	Not present	Hc11

Digital outputs – Master Circuit 1

Digital outputs – Slave Circuit 2

Ref.	Description	Configuration param.s	Ref.	Description	Configuration param.s
C-NO1	Compressor 1	Hc51; C036	C-NO1	Compressor 1	Hc61; C036
C-NO2	Compressor 2	Hc52; C036	C-NO2	Compressor 2	Hc62; C036
C-NO3	User pump 1	Hc53; U063	C-NO3	User pump 2	Hc63; U063
C-NO4	Reversing valve	Hc54; U066; S063; U065	C-NO4	Reversing valve	Hc64; U66; S063; U065
C5-NO5	Alarm	Hc55; U064	C5-NO5	Alarm	Hc65
C6-NO6	Source water pump	Hc56; Hc12	C6-NO6	Frosts protection heater	Hc66



Notice: (*) the configuration of the output depends on the type of unit: heat pump (reverse-cycle) => reversing valve; Chiller with free cooling (master only) => FC valve; otherwise => Frost protection heater.

Analogue outputs – Master Circuit 1

Ref.	Description	Type	Configuration parameters	Notes
Y1	On-Off source pump (panel model)	0-10V	Hc71	CONVONOFF
Y2	Not used	0-10V	Hc72	

Analogue outputs – Slave Circuit 2

Ref.	Description	Type	Configuration parameters	Notes
Y1	Not used	0-10V	Hc81	-
Y2	Not used	0-10V	Hc82	

2.5 Chillers, On/Off compressors and unipolar ExV expansion valve



Important: The black lines refer to the electrical connections, the grey lines the serial connections between controller and options (I/O expansion for the second circuit, EVD and EVO).

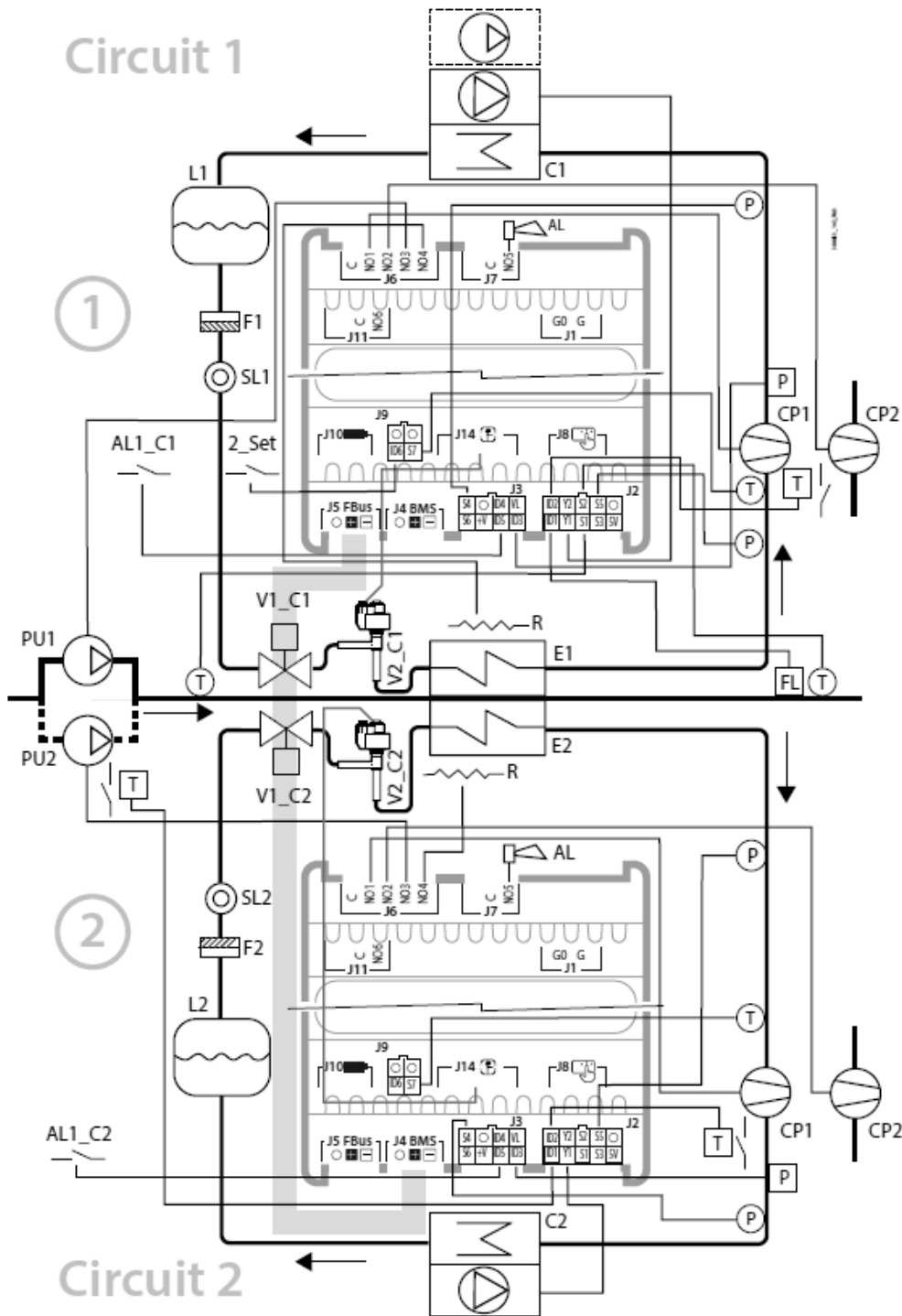

Ref.	Description	Ref.	Description	Ref.	Description
C1/C2	Condenser 1/2	SL1/2	Liquid sightglass 1/2	R1/2	Frost protection heater
E1/E2	Evaporator 1/2	F1/2	Filter-drier 1/2	P	Pressure probe/pressure switch
V1_C1	Solenoid valve circuit 1	FL	Flow switch	T	Temperature probe / thermostat
V1_C2	Solenoid valve circuit 2	PU1/2	User pump 1/2	CP1/2	Compressor 1/2
V2_C1	Electronic expansion valve circuit 1	L1/2	Liquid receiver 1/2	AL	Alarm
V2_C2	Electronic expansion valve circuit 2	2_Set	2 nd set point	AL1_C1/2	Remote alarm circuit 1/2

Analogue inputs – Master Circuit 1

Ref.	Description	Type	Configuration parameters
S1	Return temperature from user	NTC	Hc31
S2	Delivery temperature to user	NTC	Hc32
S3	Not present	-	Hc00
S4	Condensing pressure	0-5V	Hc34; C040; C041; C042
S5	Evaporation pressure	0-5V	Hc35; C037; C038; C039
S6	Not present	-	Hc03; U025; U026; U027
S7	Suction temperature	NTC	Hc04

Analogue inputs – Slave Circuit 2

Ref.	Description	Type	Configuration parameters
S1	Not present	-	Hc41
S2	Not present	-	Hc42
S3	Not present	-	Hc00
S4	Condensing pressure	0-5V	Hc44; C040; C041; C042
S5	Evaporation pressure	0-5V	Hc45; C037; C038; C039
S6	Not present	-	Hc05; U025; U026; U027
S7	Suction temperature	NTC	Hc47



Notice: the discharge temperature probe is automatically assigned type NTC-HT

Digital inputs – Master Circuit 1

Ref.	Description	Configuration parameters
ID1	User pump flow switch	Hc14; U060
ID2	Compressor 1 overload	Hc15; C035
ID3	High pressure switch	C034
ID4	Not present	Hc06; C035; U059; U058; U062; U057; U061
ID5	Remote alarm	Hc07; C035; U059; U058; U062; U057; U061
ID6	2 nd set point	Hc08; C035; U059; U058; U062; U057; U061

Digital inputs – Slave Circuit 2

Ref.	Description	Configuration parameters
ID1	Pump 2 overload	Hc16; U061
ID2	Compressor 1 overload	Hc17; C035
ID3	High pressure switch	C034
ID4	Not present	Hc09; C035; U059; U058; U062; U057; U061
ID5	Not present	Hc10; C035; U059; U058; U062; U057; U061
ID6	Not present	Hc11

Digital outputs – Master Circuit 1

Digital outputs – Slave Circuit 2

Ref.	Description	Configuration param.s	Ref.	Description	Configuration param.s
C-NO1	Compressor 1	Hc51; C036	C-NO1	Compressor 1	Hc61; C036
C-NO2	Compressor 2	Hc52; C036	C-NO2	Compressor 2	Hc62; C036
C-NO3	User pump 1	Hc53; U063	C-NO3	User pump 2	Hc63; U063
C-NO4	Reversing valve	Hc54; U066; S063; U065	C-NO4	Reversing valve	Hc64; U66; S063; U065
C5-NO5	Alarm	Hc55; U064	C5-NO5	Alarm	Hc65
C6-NO6	Not used	Hc56;	C6-NO6	Not used	Hc66



Notice: (*) the configuration of the output depends on the type of unit: heat pump (reverse-cycle) => reversing valve; Chiller with free cooling (master only) => FC valve; otherwise => Frost protection heater.

Analogue outputs – Master Circuit 1

Ref.	Description	Type	Configuration parameters	Notes
Y1	Modulating/On-off fan	0-10V	Hc71	FCS1*0/CONVONOFF
Y2	Not used	0-10V	Hc72	

Analogue outputs – Slave Circuit 2

Ref.	Description	Type	Configuration parameters	Notes
Y1	Modulating/On-off fan	0-10V	Hc81	FCS1*0/CONVONOFF
Y2	Not used	0-10V	Hc82	

3. Initial Configuration

3.1 APPLICA App

The “Applica” app can be used to configure the controller from a mobile device (smartphone, tablet), via NFC (Near Field Communication) and Bluetooth (BLE). Users can both configure the commissioning parameters and set groups of preset parameters according to specific needs (recipes).

Once the Carel “Applica” app has been installed and opened (see the paragraph “Mobile device”, proceed as follows:

1. For NFC devices, move (A) the mobile device near to the μ Chiller user terminal (the position of the NFC antenna on the mobile device must be identified in order to place it over the display): wait for the signal that the device has been read (B).
2. For Bluetooth devices (C), select the “SCAN BLUETOOTH” option, then choose the device from the list.

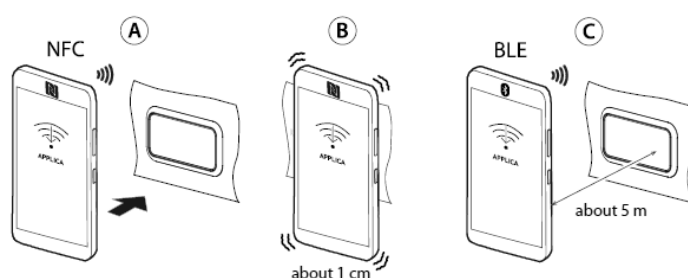

3.1.1 Applica: Date & hour settings

Applica includes a feature for setting the date and time on μ Chiller in just one simple step, copying the values from the mobile device.

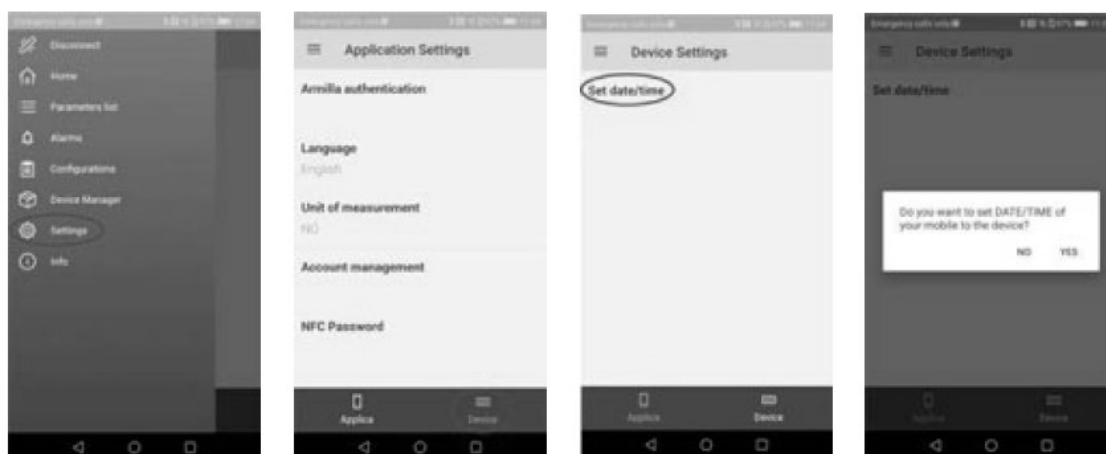

Procedure:

1. open Applica on the mobile device;
2. access the controller via NFC or Bluetooth, entering your profile credentials;
3. access the menu on the command bar at the top left;
4. select “set date/time”:
5. confirm;
6. with an NFC connection, move the device near to the user terminal to write the copied values



Notice: with a Bluetooth connection, the values are copied on confirmation.

3.1.2 Unit set-up parameter list



Notice: follow the order shown in the table to configure the Unit set-up parameters.

Par.	Description	Def.	Min.	Max.	Uom
U077	Type of unit	0	0	0	
	0=CH;				
	1=HP;				
	2=CH/HP				
	3=Cooling-only condensing unit;				
	4=Reverse-cycle condensing unit;				
	5=Cooling-only air/air				
	6=Reverse cycle air/air/air				
S068	Source type (0=Air; 1=Water)	0	0	1	-
U076	Number of system pumps	1	1	2	-
C046	No. of unit circuits	1	1	2	-
C047	Type of compressors used (0=1 On/Off; 1=2 On/Off; 2= 1 BLDC; 3= 1 BLDC+On/Off)	0	0	1/3	-
S065	Type of source fan (0/1=Modulating/On-OFF)	0	0	1	-
S064	Type of source air circuit (0=Independent; 1=Common)	0	0	1	-
S072	Source pump activation	0	0	1	-
	0=Always on				
	1=On with compressors on				
	2=control on condensing temperature				
E047	ExV driver (0=Disabled; 1=Built-in;2=EVD Evolution)	0	0	2	-
E046	EVD Evolution: valve (1=VAREL ExV,...) (*) (*) see EVD Evolution manual for the complete list of selectable valves	1	1	24	-
E020	MOP in cooling: threshold	30.0	-60.0	200.0	°C
E022	MOP in heating: threshold	20.0	-60.0	200.0	°C
C017	Max high pressure threshold (HP)	65.0	0.0	999.9	°C
C018	Min low pressure threshold (LP)	0.2	-99.9	99.9	bar
U068	Free cooling: enable (0/1=no/yes)	0	0	1	-
U074	Free cooling type (0=Air; 1=Remote coil; 2=Water)	0	0	2	-
U071	Design free cooling delta T	8.0	0.0	99.9	K
U061	System pump overload: input logic (0/1=NC/NO)	0	0	1	-
U065	Free-cooling valve: output logic (0/1=NO/NC)	0	0	1	-
S063	Reversing valve: output logic (0/1=NO/NC)	0	0	1	-
S054	4-way valve: pressure differential for reversing	3.0	0.0	999.9	bar
C049	Low pressure switch alarm delay on compressor activation	90	0	999	-
C050	Low pressure switch alarm delay with compressor on	15	0	999	-
C051	Low pressure switch input logic (0=NC; 1=NA)	0	0	1	-
S053	Defrost synchronisation (0=Independent, 1=Separate, 2=Simultaneous)	0	0	2	-
U006	Cooling set point: minimum limit	5.0	-99.9	999.9	°C
U007	Cooling set point: maximum limit	20.0	-99.9	999.9	°C
U008	Heating set point: minimum limit	30.0	0.0	999.9	°C
U009	Heating set point: maximum limit	45.0	0.0	999.9	°C
Hc13	Buzzer (0/1=No/Yes)	1	0	1	-
U081	High/low pressure and frost alarm reset configuration	7	0	7	-
	0= HP1-2/LP1-2/A1-2/Manual frost protection				
	1= HP1-2/LP1-2/A1-2/Automatic frost protection				
	2= HP1-2/A1-2 Manual frost protection LP1-2 automatic				
	3= HP1-2 manual LP1-2/A1-2 Automatic frost protection				
	4= HP1-2/LP1-2 manual A1-2/Automatic frost protection				
	5= HP1-2/LP1-2 (3 times in an hour) manual; A1-2/Automatic frost protection				
	6= HP1-2/LP1-2 (3 times in an hour) manual; A1-2/Manual frost protection				
	7=HP1-2 manual/LP1-2 (3 times in an hour)/Manual frost protection				



3.1.3 mCH2 parameters

Par.	Description	Def.	Min.	Max.	Uom
F027	Compressors at part load (0=NO, 1=YES)	0	0	1	-
F003	Number of evaporators (0=1; 1=2)	0	0	1	-
F007	Sensor S4 installed on the source heat exchanger (0=No, 1=Yes: in CH mode reads condensing temp., in HP mode reads evap. temp.)	0	0	1	-
F008	Frost protection alarm delay	10	0	999	-
F009	Supply air temperature limit threshold	14.0	0.0	99.9	°C
F010	Supply air temperature limit diff.	4.0	0.0	20.0	°K
F011	Heater dig. output logic (0=NO; 1=NC)	0	0	1	-
F012	Offset on set point in cooling operation for the heaters	1.0	0.0	99.9	°K
F013	Differential on set point in cooling mode for the heaters	0.5	0.2	99.9	°K
F014	Offset on set point in heating mode for the heaters	3.0	0.0	99.9	°K
F015	Differential on set point in heating mode for the heaters	1.0	0.2	99.9	°K
F016	Heaters active during defrost (0=No, 1=Yes)	0	0	1	-
F017	Supply fan operating mode (0=Always ON; 1=ON by temp. control)	0	0	1	-
F018	Hot-start set point	40.0	0.0	99.9	°C
F019	Hot-keep differential	5.0	0.0	99.9	°K
F020	Compressor request logic from digital input (0=NC; 1=NO)	1	0	1	-
F021	Mixed water outlet temperature probe calibration (S1 expansion)	0.0	-99.9	99.9	°K
F022	Evaporator 2 water outlet temperature probe calibration (S2 expansion)	0.0	-99.9	99.9	°K
F023	Direct relationship between digital inputs and digital outputs for condensing unit (0=No, 1=Yes)	0	0	1	-
F024	Manual heater 1 management (0=AUTO; 1= OFF; 2=ON)	0	0	2	-
F025	Manual heater 2 management (0=AUTO; 1= OFF; 2=ON)	0	0	2	-
F026	Compressors off at low outside temperature (air/air)	-40.0	-40.0	99.9	°C

3.2 APPLICA Desktop

Applica Desktop is a program intended for manufacturers and installers of units fitted with the μ Chiller controller. It can be downloaded from ksa.carel.com.

The Applica Desktop offers the possibility to:

- access the controller using the assigned profile;
- create configurations;
- apply configurations;
- clone a unit configuration, i.e. copy all of the unit's parameter values;
- complete the commissioning procedure;
- troubleshoot any problems on the unit.



Notice:

- Applica Desktop can be used as an alternative to the Applica app, and requires an internet connection;
- For the physical connection to the BMS port on μ Chiller, use the USB/RS485 converter P/N CVSTDUMORO

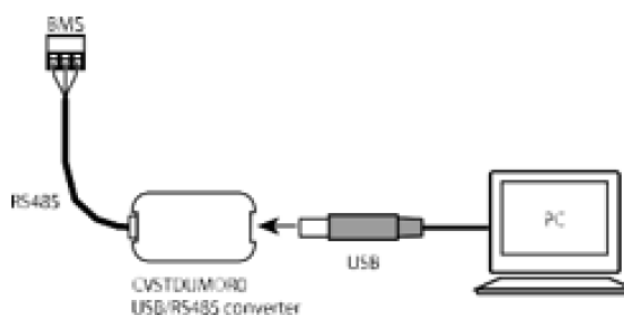

3.2.1 Preparing for operation

1. Access KSA, "Software & Support", " μ Chiller" section.
2. Select the "Configurations" folder.
3. For μ Chiller Standard, Enhanced and Legacy models (with On/Off compressor), select the "Refrigerants" section and then the refrigerant charged on the unit.
4. Connect to the BMS port on the μ Chiller controller;
5. Open Applica Desktop; a window will be opened with the right part of the top bar as shown below:

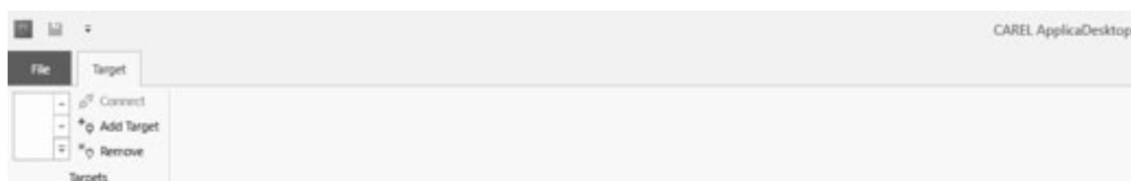

6. Select “Add target” and assign it a meaningful name (e.g.
7. In the “COM Port” field, enter the COM port used for the USB connection to the USB/RS485 converter;
8. Configure the connection parameters (Baudrate=115200, Bits=8, Parity=None, Stop Bits=Two, Serial Node=1) as shown in the figure (the data are saved automatically);
9. Use “Connect” to connect to the μ Chiller (which must be powered on).



3.2.2 Applica Desktop: date and time setting

Applica Desktop can set the date and time on μ Chiller in just one simple step, copying the values from the PC to the controller

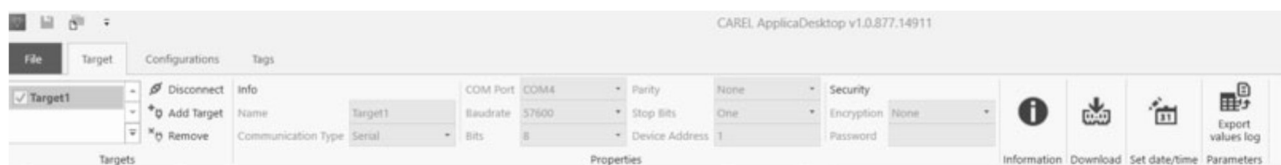

Procedure:

1. Once connected, select “Set date & time”;
2. In the pop-up window, confirm synchronisation of the time and date on μ Chiller with the PC

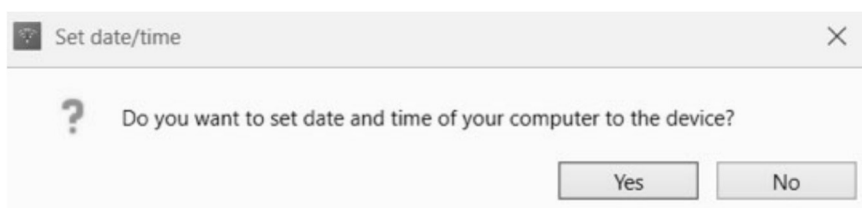



4. User Interface

4.1 Introduction

μChiller uses the user terminal to display the alarms, the main variables and to set the unit set points (User level) and manual functions (Service level). The terminal has a 7- segment LED display with two rows: the top row is 3-digit plus sign and decimal point; the bottom row is 4-digit plus sign (this can also display the hour format -hh:mm and date - MM:DD). There is a buzzer, 14 operating icons and 4 buttons for scrolling and setting the parameters. The terminal has NFC (Near Field Communication) and Bluetooth (depending on the model) connectivity for interaction with mobile devices (on which the Carel “Applica” app has been installed, available on Google Play for the Android operating system).



Notice: access levels: U=User; S=Service; M=Manufacturer. See the parameter table.

The unit of measure on the display can be changed via parameter UoM, accessed at a Service level, including in the direct access functions menu.

Code	Description	Def.	UoM	Min.	Max.	Lev.
UoM	Unit of measure 0=°C/barg – 1=°F/psig	0	-	0	1	S

The information and parameters accessible from the terminal and from the Applica app depend on the access level and the unit configuration parameters.

4.2 User Terminal

	Key	
	1	Keypad
	2	Main field
3	Device status and operating mode icons	



Note: the user terminal only allows access to certain parameters at the User and Service levels: to access all of the Service and Manufacturer parameters, use the Carel Applica app or the configuration and commissioning tool.

4.2.1 Keypad

Button	Description	Function
	UP	<ul style="list-style-type: none"> • When scrolling: go to the previous parameter • In programming mode: increase the value
	DOWN	<ul style="list-style-type: none"> • When scrolling: go to the next parameter • In programming mode: decrease in value Main menu: <ul style="list-style-type: none"> • pressed briefly: unit dashboard display • pressed and held (3 s): access User parameters (set point, unit on-off , ...)
	Alarm	<ul style="list-style-type: none"> • Pressed briefly: display active alarms and mute buzzer • Pressed and held (3 s): reset alarms.
	PRG	<ul style="list-style-type: none"> • When scrolling: access parameter programming mode In programming mode: <ul style="list-style-type: none"> • pressed briefly: confirm value • pressed and held (3 s): return to the main menu

4.2.2 Icons

Icon	Function	On	Flashing
	System pump	Active	In manual operation
	Source device status (pump/fan)	Active	In manual operation
	Compressor status	Active	In manual operation (with ExV)
	Frost protection heater	Active	-
	Operating mode	Heating	-
	Operating mode	Cooling	High water temperature
	Operating mode	Defrost	Dripping after defrosting
	Operating mode	Free cooling	-
	Service	Service request on exceeding operating hours	Service request on exceeding operating hours

4.3 Standard display

At start-up, the user terminal briefly shows "NFC", indicating that the NFC interface is available on the user terminal for communication with mobile devices, and then the standard display is shown. The standard display shows:

- on the top row: the delivery water temperature;
- on the bottom row, when the unit is on, the return water temperature; when the unit is off, it shows "OFF".



Note: "bLE" flashes on the display during "Bluetooth" communication.

4.3.1 Dashboard

From the main menu, press DOWN to access information on the status of the devices and the temperatures, superheat values, etc. for the two circuits:

- unit "OFF" and the reason for shutdown:
 - "diSP" from keypad;
 - "dl" from remote contact (via digital input);
 - "Schd" from time band (scheduler);
 - "bMS" from BMS;
 - "ChnG" from operating mode changeover (heating/cooling);
 - "AlrM" from alarm.
 - "CMP" compressors;
 - "AFC1" source water delivery temperature circuit 1;
 - "AFC2" source water delivery temperature circuit 2;
 - "EuP1" evaporation temperature circuit 1;
 - "SSH1" superheat circuit 1;
 - "Cnd1" condensing temperature circuit 1;
 - "dSt1" BLDC compressor discharge temperature circuit 1;
 - "EuP2" evaporation temperature circuit 2;
 - "SSH2" superheat circuit 2;
 - "Cnd2" condensing temperature circuit 2;
 - "dSt2" BLDC compressor discharge temperature circuit 2; and if the access level is "Service":
 - "Hd00" supervisor address (BMS);
- and if the access level is "Service":
- "Hd01" BMS baud rate;
 - "Hd02" BMS communication parameters;
 - "ESC" to exit the dashboard.

Example



Go to the standard display.



Press DOWN: CMP indicates that compressor 1 is on (o) and compressor 2 is off (.).

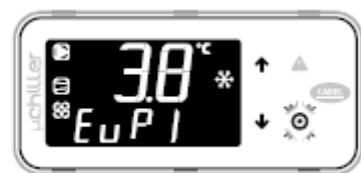

Press DOWN: EuP1 indicates the evaporation temperature in circuit 1 (3.8°C).



Press DOWN: Cnd1 indicates the condensing temperature in circuit 1 (40.8°C).



To return to the standard display, press PRG (corresponding to ESC).

4.3.2 Direct access functions

The user terminal only provides access to the basic configuration parameters, such as direct functions and active alarms without password protection, or, with password protection, to the parameters used to configure and optimise the unit.

Press DOWN for 3 s to access the direct access functions:

- set point;
- switching unit on and off;
- change operating mode (cooling/heating, only on reverse-cycle units);
- select unit of measure.

In programming mode, the bottom row shows the parameter code, and the top row shows the value.

Procedure

Press:

- DOWN for 3 s to access the parameters (User level, no password required);
- UP and DOWN to scroll and set the parameters;
- PRG to change the parameter value and save the changes;
- PRG (3 s) or ESC to return to the standard display.



1. Go to the standard display



2. Press DOWN for 3 s: the current set point (SEtA) is shown - read-only



3. Press DOWN: the cooling set point (SEtC) is shown



4. Press PRG: the value flashes; press UP/DOWN to change the value; PRG to confirm.



5. Press DOWN: the heating set point (SEtH) is shown - for heat pump units only.



6. Press DOWN: the unit ON/OFF function (UnSt) is shown.



7. Press DOWN: the function for switching from cooling (C) to heating (H) mode (ModE) is shown – for heat pump units only.



8. Press DOWN: the manual defrost function (dFr) is shown – Service level and reverse-cycle A/W units only.



9. Press DOWN: the function to delete the alarm log (ClrH) is shown – Service level only.



10. Press DOWN: the unit of measure selection (UoM) is shown



11. After having completed the settings, to exit either:
– from the categories press ESC and then PRG;
– press PRG for 3 s

4.3.3 Programming mode

Go to the standard display and press PRG to enter programming mode.

Procedure

Press:

- PRG to access the parameters with password protection;
- UP and DOWN to scroll and set the parameters;
- PRG to change the parameter value and save the changes;
- PRG (3 s) or ESC to return to the standard display.



1. Go to the standard display



2. Press PRG: the password prompt (PSd) is shown



3. Press PRG: the first digit of the password flashes; set the value, press PRG. The second digit now flashes; enter the other digits to complete the password.



4. Press PRG: if the password is correct, the first parameter category is shown: PLt (= system)



5. Press PRG: the first parameter is shown: U002 (Pump 1 manual control)



6. Press PRG: the value flashes; press UP/DOWN to change the value; PRG to confirm.



7. Press UP/DOWN to display the other parameters.



➡ **Note:** User password: 1000; See the parameter table.

4.3.4 Programming menu



Category PLt (system): identified by code Uxxx, these parameters all relate to control and management of the system units.



Category EEV (ExV valve): identified by code Exxx, these parameters all relate to control and management of the electronic expansion valve (s).



Category CMP (compressors): identified by code Cxxx, these parameters all relate to control and management of the compressors and refrigerant circuits.



Category Src (source): identified by code Sxx, these parameters all relate to control and management of the condenser / source.



Category CLc (Clock): identified by code Haxx, these are the parameter for setting the date/time.



Category Hst (Alarm log): access the alarm log. Each event is described with the date (in the format DD MM) and time (in the format hh:mm) alternating.



Use Log- Out to exit the category.



Use ESC to return to the standard display.



Notes:

- the Service password also accesses the User parameters;
- if no button is pressed, after around 3 minutes the terminal will automatically return to the standard display.

5. Functions

5.1 Temperature control

µChiller can control either the unit's return or delivery water temperature. The return (from user) and delivery (to user) water temperature probes can be installed on any of the channels. See the Installation chapter.

5.1.1 PID Control

Two types of PID control are available:

- PID control at start-up;
- PID control in operation.

For each type of PID control, the following parameters can be set:

- Control probe (return or delivery);
- Proportional gain (Kp);
- Integral time (action disabled when time set to 0);
- Derivative time (action disabled when time set to 0).

The control set point and the operating mode (heating / cooling) are the same for both control types:

- control at start-up is aimed at preventing excess capacity being called. Indeed, as when starting the exact status of the units (loads) is not known, but rather only the temperature, capacity needs to be delivered gradually, awaiting the reaction from the system. Control can be applied to the water return temperature, using a low gain and a sufficiently high integral time, greater than the system time constant (120- 180 s, considering a system time constant of at least 60 s, corresponding to a minimum water content of 2.5 l/kW).
- control in operation needs to be more reactive, so as to respond quickly to any variations in load and keep the delivery water temperature as close as possible to the set point. In this case, the time constant depends on the response of the compressor-evaporator system, and is in the order of a few tens of seconds (slower with tube bundle evaporators, faster with plate evaporators).

The following table shows the recommended values (to be calibrated if necessary during system commissioning), according to the type of evaporator used

Code	Description	Evaporator	
		Tube bundle	Plate
U036	Control probe at start-up - 0=Return 1=Delivery	Return	Return
U039	PID at start-up: Kp	6.0	6.0
U040	PID at start-up: Ti - 0: integral action disabled	180 s	180 s
U041	PID at start-up: Td - 0: derivative action disabled	0 s	0 s
U038	Control probe in operation - 0=Return 1=Delivery	Delivery	Delivery
U042	PID in operation: Kp	10.0	10.0
U043	PID in operation: Ti - 0: integral action disabled	120 s	120 s
U044	PID in operation: Td - 0: derivative action disabled	3 s	3 s

The control sequence is as follows:

1. when the unit is Off, both PID controls are disabled;
2. when the unit starts, following the set user pump – compressor delay, the PID at start-up is enabled and generates a capacity request (percentage) that is then processed so as to activate the compressors;
3. if this request is sufficient, one compressor will be started;
4. once the compressor has started, after a set time, control switches from PID at start- up to PID in operation;
5. when the controller requests deactivation of the compressors, these are enabled to stop;
6. after the last compressor has been stopped, restart is managed using the PID at start-up.

If the delay between PID at start-up/in operation is set to 0, PID control in operation will always be active.

User	Code	Description	Def.	Min.	Max.	Uom
S	U047	Compressor activation delay after user pump	30	0	999	s
S	U037	PID control delay at start-up/operation	180	0	999	s

5.1.2 Proportional control

If the desired control is only proportional to the water outlet or return temperature, consider the relationship:

$$K_p = 100/BP$$

For example, to have a proportional band of 2K, set the value of Kp to 50.

The following are the parameter settings required to control the return temperature:

User	Cod.	Description	Setting	UoM	Note
S	U036	Control probe at start-up - 0=Return 1=Delivery	0	-	-
S	U037	PID control delay at start-up/operation	180	s	Not significant
	U038	Control probe in operation - 0=Return 1=Delivery	0	-	
	U039	PID at start-up: Kp	50.0	-	=> Proportional band = 2K
			34.0		=> Proportional band = 3K
			25.0		=> Proportional band = 4K
			20.0		=> Proportional band = 5K
	U040	PID at start-up: Ti - 0: integral action disabled	0	s	
	U041	PID at start-up: Td - 0: derivative action disabled	0	s	
	U042	PID in operation: Kp	=U039	s	Same as Kp at start-up
	U043	PID in operation: Ti - 0: integral action disabled	0	s	
	U044	PID in operation: Td - 0: derivative action disabled	0	s	

5.1.3 Set point compensation

µChiller adjusts the set point based on the outside temperature.



Notice: this function can only be enabled if the outside temperature probe is fitted.

The compensation (positive or negative) is determined by:

1. start compensation start (in cooling/heating);
2. end compensation threshold (in cooling/heating);
3. maximum compensation value (in cooling/heating).

User	Code	Description	Def.	Min.	Max.	Uom
S	U010	Enable set point compensation: 0/1=no/yes	0	0	1	-
U	SEtC	Cooling set point	7.0	U006	U007	°C/°F
S	U011	Cooling compensation: start	25.0	-99.9	999.9	°C
S	U012	Cooling compensation: end	35.0	-99.9	999.9	°C
S	U013	Cooling compensation: maximum value	5.0	-99.9	999.9	K
U	SEtH	Heating set point	40.0	U008	U009	°C/°F
S	U014	Heating compensation: start	5.0	-99.9	999.9	°C
S	U015	Heating compensation: end	-10	-99.9	999.9	°C
S	U016	Heating compensation: maximum value	5.0	-99.9	999.9	K

Compensation in cooling:

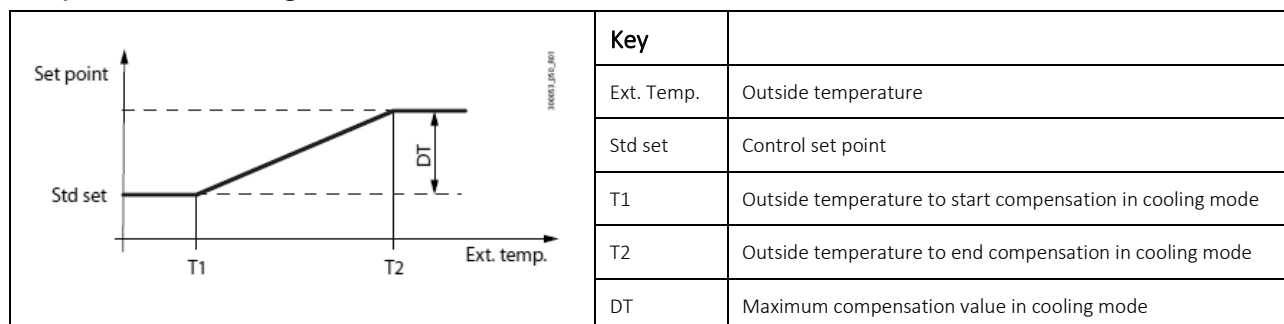

Compensation in heating:

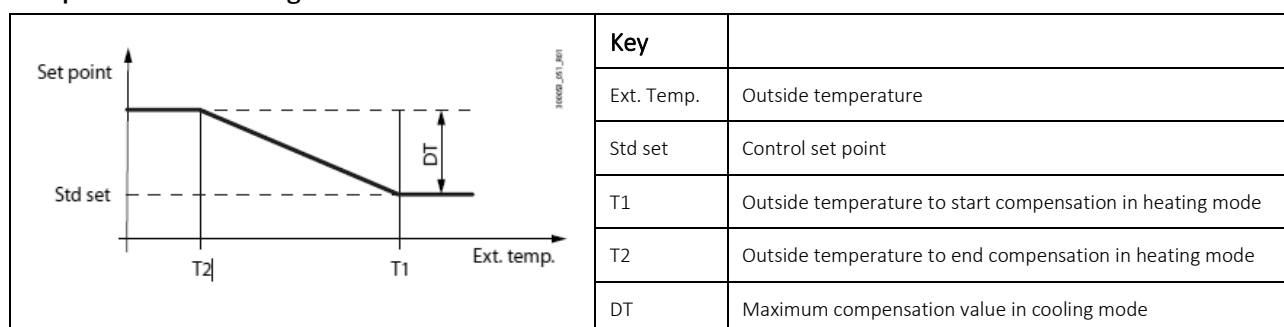

5.1.4 Request from BMS

The request can be managed directly from a BMS, bypassing normal temperature control and enabling the external request signal (0-100.0%) via the specific Modbus serial variable (BMS_PwrReq, HR 331). This operation is enabled via another serial variable (En_BMS_PwrReq, CS 22).



Note: if the supervisor is offline, the unit continues to operate in stand-alone mode, regardless of the request from the BMS.

5.1.5 High evaporator outlet temperature alarm

μChiller activates an alarm when the evaporator outlet temperature exceeds the threshold set by the user (via the offset relative to the control set point). When the outlet temperature exceeds the threshold, a counter starts and after a delay (settable), the alarm is activated. An initial delay disables the alarm in the transient period when the unit is starting.



Notes:

- the alarm is only available on chiller units.
- the high temperature alarm can be used to activate a backup unit in critical applications.

User	Code	Description	Def.	Min.	Max.	Uom
U	SetA	Current set point	-	-999.9	999.9	°C
S	U031	High water temperature alarm: offset	10.0	0.0	99.9	K
S	U032	High water temperature alarm: delay at start-up	15	0	99	Min
S	U033	High water temperature alarm: delay in operation	180	0	999	s

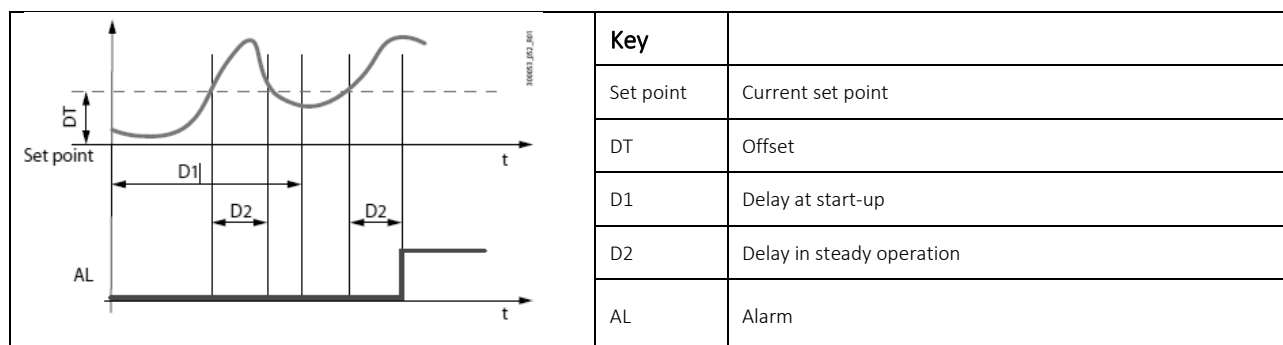

5.2 User pump

μChiller can manage up to two user- side pumps (depending on the hardware used and the required configuration). A delay can be set between pump and compressor activation (= temperature control enabled). A delay can also be set between the deactivation of the last compressor and the pump. If when the unit shuts down the compressors have been shut down for at least the “user pump shutdown delay after compressor”, then the pump is stopped immediately.

User	Code	Description	Def.	Min.	Max.	Uom
S	U047	Compressor activation delay after user pump	30	0	999	s
S	U048	User pump shutdown delay after compressor	180	0	999	s

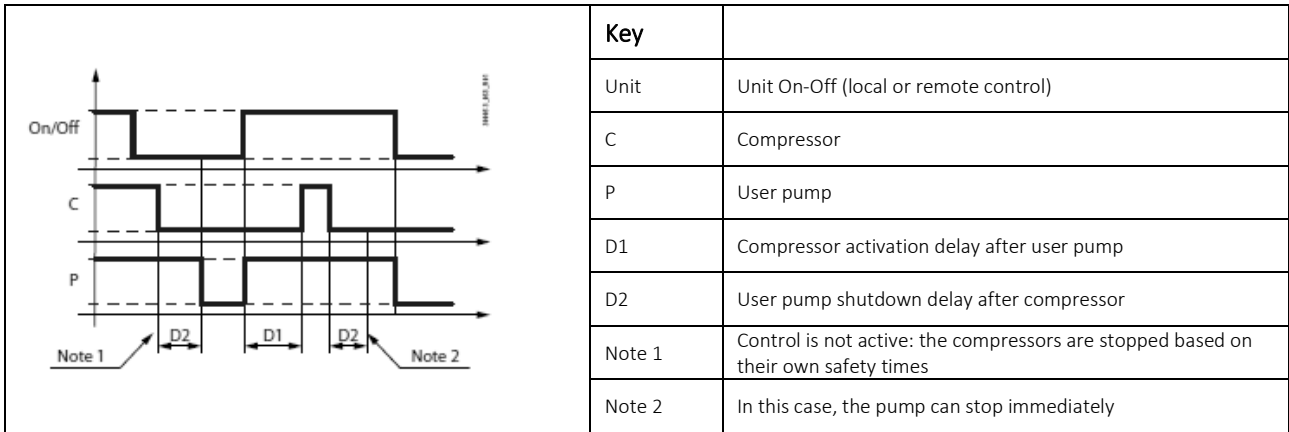

Below is a diagram that represents operation for the configuration with one pump only:

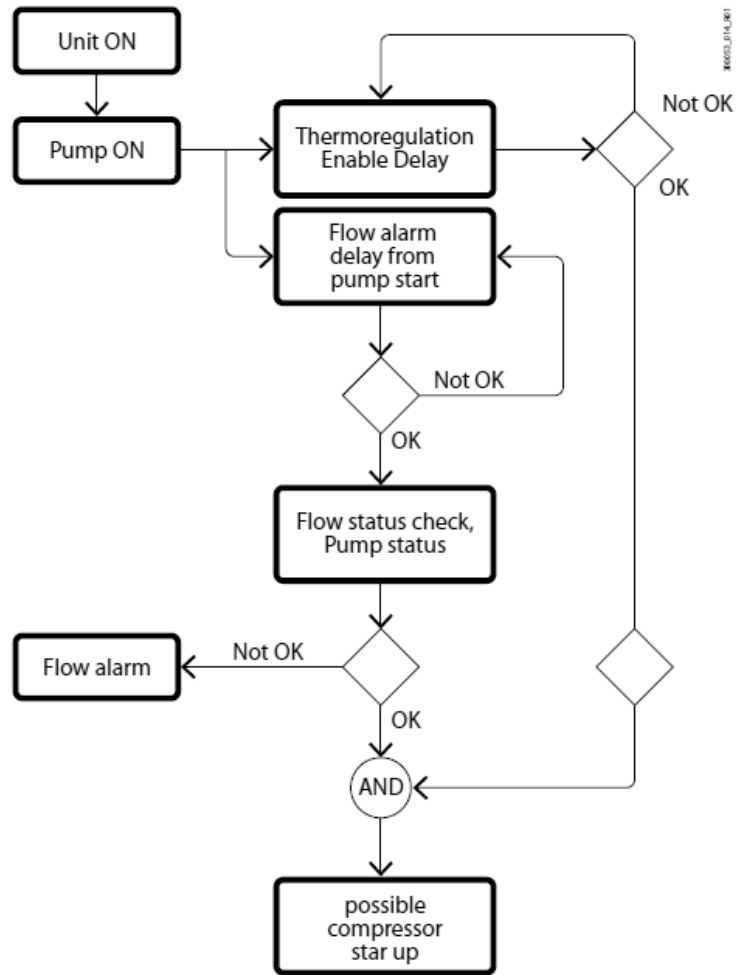

Temperature control is enabled only after the flow alarm delay from pump on, so as to prevent the compressors from starting if there is no fluid flow.

Temperature control is enabled only after the flow alarm delay from pump on, so as to prevent the compressors from starting if there is no fluid flow.

Depending on the configuration, up to two user pumps can be enabled. μ Chiller includes the following features:

- with two pumps, automatic rotation to ensure fluid circulation and equalisation of operating hours. Rotation is performed:
 - at the end of a period that can be set, in hours;
 - when there is an overload alarm on the active pump.
- management of the pump overload alarm (if available, depending on the controller and configuration). Fault signal and immediate pump deactivation.
- Management of a flow switch that monitors fluid circulation in the system.
- frost protection with unit off: the pump is started so as to activate fluid circulation (when the unit is on, the function is disabled).
- pump anti-blocking: if the pump is off for more than a week, it is activated for 3 seconds.

User	Code	Description	Def.	Min.	Max.	Uom
S	U049	User pump rotation time	12	0	999	h

5.2.1 Cyclical pump activation during standby

When the chiller serves a chilled water tank (for example, in winemaking applications), the pump does not need to keep running, consequently energy can be saved by stopping the pump when the cooling demand is met.

A function can be activated to:

- switch the pump off after the compressors are stopped by the temperature controller;
- activate the pump periodically, in order to reactivate the compressors and satisfy demand from the units.

User	Code	Description	Def.	Min.	Max.	Uom
S	U078	Unit pump in standby: enable On-Off cycles	0	0	1	-
S	U079	Unit pump in standby: On time	3	1	15	min
S	U080	Unit pump in standby: Off time	15	3	99	min

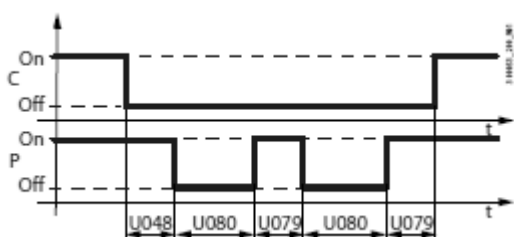

5.3 Frost protection control

Frost protection control can be managed using the evaporation pressure probe, which directly monitors the conditions of the evaporator, or using the water temperature probe. In the latter case, the delivery water temperature or the source water temperature in the water/water unit is used in heating mode).

User	Code	Description	Def.	Min.	Max.	Uom
S	U082	Frost protection control type 0=Evaporation temperature 1=Water temperature	0	0	1	-

5.3.1 Frost protection alarm

When there is a frost alarm on the evaporator, the corresponding circuit is shut down. Each circuit manages its own evaporation pressure probe, and consequently also the frost protection alarm. The evaporation temperature value is filtered based on an exponential distribution formula that takes into consideration the thermal mass of the evaporator so as to avoid false alarms at start-up. A specific algorithm uses this filtered value and activates the alarm if the frost protection threshold is exceeded.

User	Code	Description	Def.	Min.	Max.	Uom
S	U050	User side frost protection: alarm threshold	-0.8	-99.9	999.9	°C
S	U051	User side frost protection: differential	30.0	0.0	999.9	K
S	U052	User-side frost protection: delay time at 1K	30	0	999	s

The figure shows the action of the filter on the evaporation temperature, according to the exponential distribution formula.

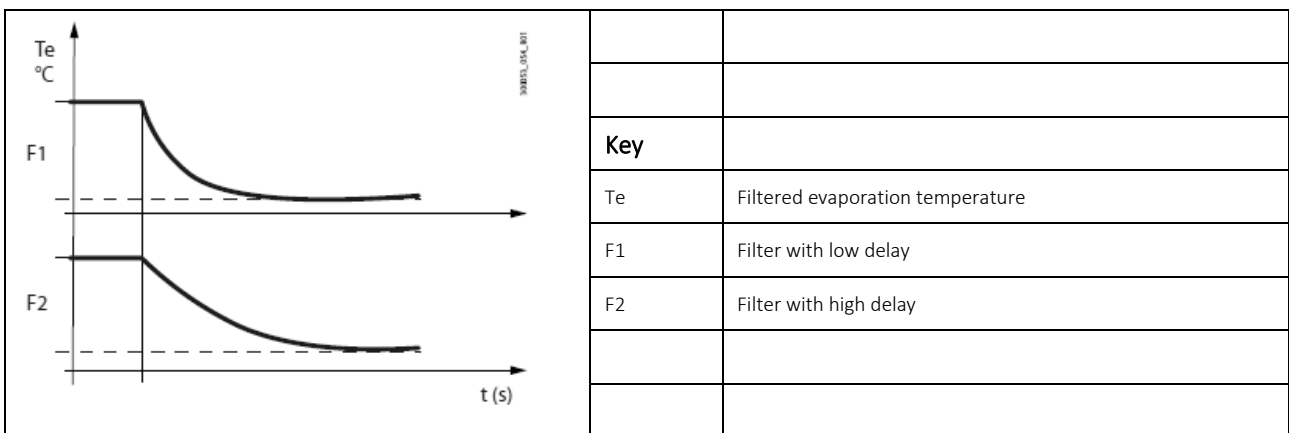

When the filtered evaporation temperature falls below the alarm threshold, a counter is activated, and the counter time-out is either increased or decreased based on the deviation of the evaporation temperature from the frost protection threshold, until reaching zero when the deviation from the threshold it is greater than the differential, following a hyperbolic trend. This trend imitates the actual behaviour of ice formation and ensures better protection. The following diagram shows the trend in the alarm delay time according to the deviation from the alarm threshold, using the following values: delay time at 1K=60s; differential=30K. At the threshold the delay is equal to 10 times the set value (600s in the example).

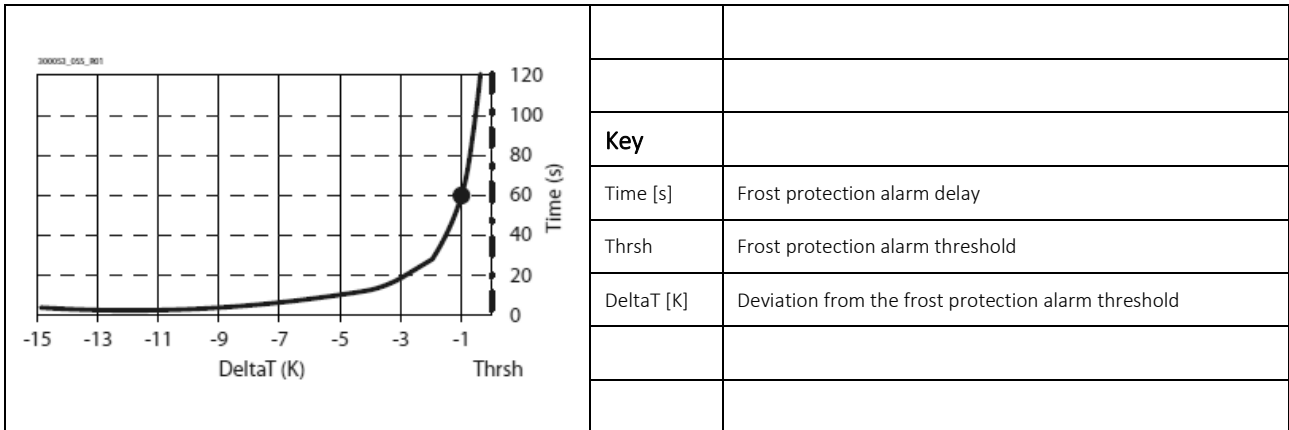

Frost protection alarm operation:

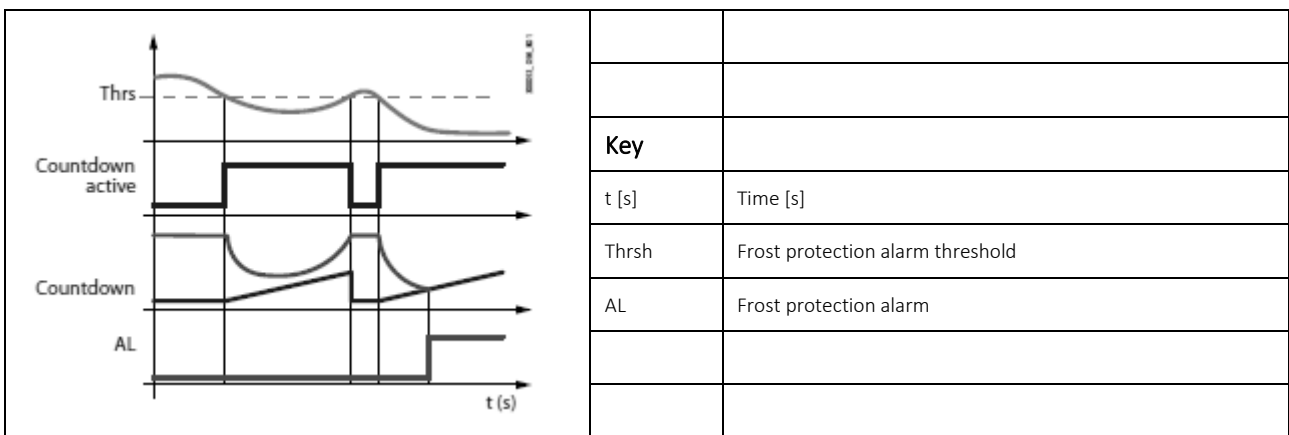

The value of the delay (at 1K) in the previous example refers to a plate evaporator; if a tube bundle evaporator is used, which has greater thermal inertia, the delay time (at 1K) can be increased to a suitable value. The following table shows the recommended values for the alarm threshold (with pure water), differential and delay, according to the type of evaporator used.

Code	Description	Recommended values based on the heat exchanger	
		Tube bundle	Plate
U050	User side frost protection: alarm threshold	-0.3°C	-1.2°C
U051	User side frost protection: differential	30.0°C	30.0°C
U052	User-side frost protection: delay time at 1K	90 s	60 s

With pure water, the frost protection threshold must be set just below zero (from - 0.8°C to - 1.5°C) to account for the heat transfer temperature gradient across the metal between the refrigerant and the water. For tube bundle heat exchangers, values close to zero (above - 0.5°C) should be considered, to guarantee better protection due to their specific mechanical construction.

5.3.2 Frost protection threshold with glide (R407C)

A correct frost protection threshold also needs to consider the minimum temperature reached inside the evaporator. When using refrigerants without glide or with minimum glide (e.g. R410A, R134a), the value coincides with the pressure-temperature conversion (dew) of the transducer fitted on the suction pipe, while for refrigerants with glide (e.g. R407C), the value to be used is lower than the pressure-temperature conversion (in the case of R407C it is 5- 6°C). The following diagram clearly shows the difference between the two temperature values (T_{in} and T_{out}) at the evaporation pressure (P_{evap}) due to the "glide" effect of the refrigerant.

P-H Diagram – Zeotropic Blend

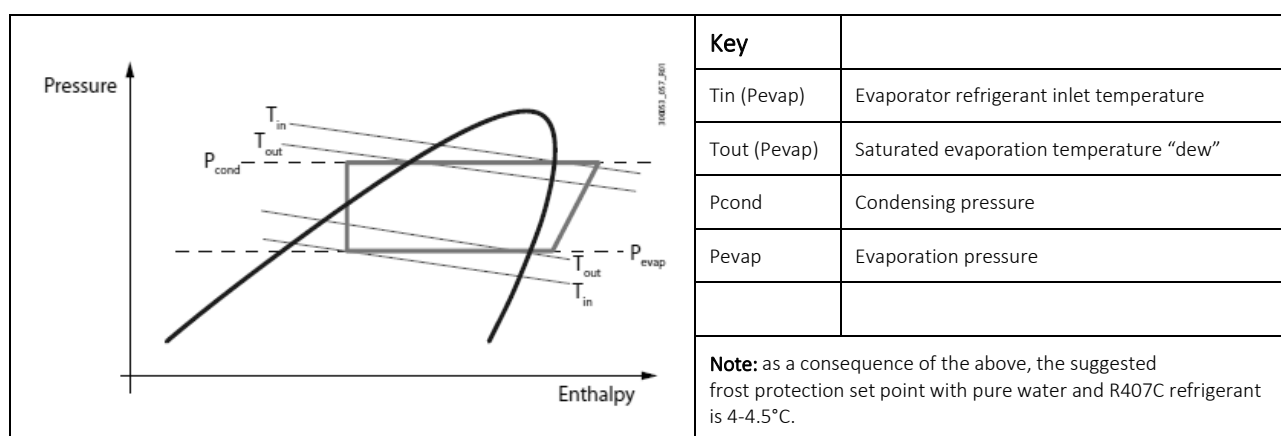

5.3.3 Frost protection alarm with water temperature

The frost protection alarm uses the water delivery probe (user) in cooling mode, while in heating mode, on water/water units, it uses the water temperature. When there is a frost alarm, the corresponding circuits are shut down. When the temperature is below the alarm threshold, the alarm is activated, and it is reset when it rises back above the threshold plus a differential.

User	Code	Description	Def.	Min.	Max.	Uom
S	U050	User side frost protection: alarm threshold	-0.8	-99.9	999.9	°C
S	U051	User side frost protection: differential	30.0	0.0	999.9	K

5.3.4 Frost prevention

The frost protection threshold on the evaporation temperature is used as the minimum evaporation temperature threshold for frost prevention. Prevention is applied by limiting circuit capacity when the threshold is exceeded.

5.3.5 Frost prevention with the unit OFF

When the unit switched off, μ Chiller provides frost protection: the water is prevented from freezing by activating a pump and/or frost protection heater. When the water temperature in the heat exchangers reaches the frost protection set point, the selected device is activated.

The probe used is the one located on the user heat exchanger outlet and source heat exchanger inlet. The following devices can be activated:

- heater;
- pump;
- heater and pump.

User	Code	Description	Def.	Min.	Max.	Uom
S	U053	Unit OFF: frost protection set point	4.0	-99.9	999.9	°C
S	U054	Unit OFF: frost protection differential	2.0	0.0	999.9	K
S	U055	Frost protection type: 0=Heater 1=Pump 2=Heater/Pump	2	0	2	-

5.4 Compressor rotation

If there is just one compressor, the temperature control request will be exactly the same as the request that the compressor needs to satisfy. On units with two compressors, μ Chiller manages rotation in order to balance compressor operating hours and starts, so as to best deliver the required capacity.

5.4.1 Frost prevention with the unit OFF

μ Chiller starts and stops the compressors based on:

- FIFO rotation (First In First Out), meaning the first compressor to start will also be the first to stop;
- activation time: the first compressor to start will be the one with the lowest number of operating hours.

If the circuit is equipped with a variable-speed (BLDC) compressor, this will always be the first to start and the last to stop.

User	Code	Description	Def.	Min.	Max.	Uom
M	C048	Compressor rotation type - 1=FIFO, 2=Time	1	1	2	-

5.4.2 Capacity distribution

μ Chiller manages the most suitable capacity distribution between the circuits so as to increase overall unit efficiency. The behaviour of capacity distribution varies based on:

- whether there are 1 or 2 circuits;
- the type of compressor(s) used: modulating (BLDC) or fixed speed;
- the ratio between compressor capacities.

To avoid simultaneous starts or stops of several compressors, there are two fixed minimum delays: one between starts (30 s) and the other (10 s) between stops.

Compressor capacity distribution in steps

Below is an example of capacity distribution with two circuits in the tandem configuration with two fixed-speed compressors (scroll), each with the same capacity, and FIFO rotation.

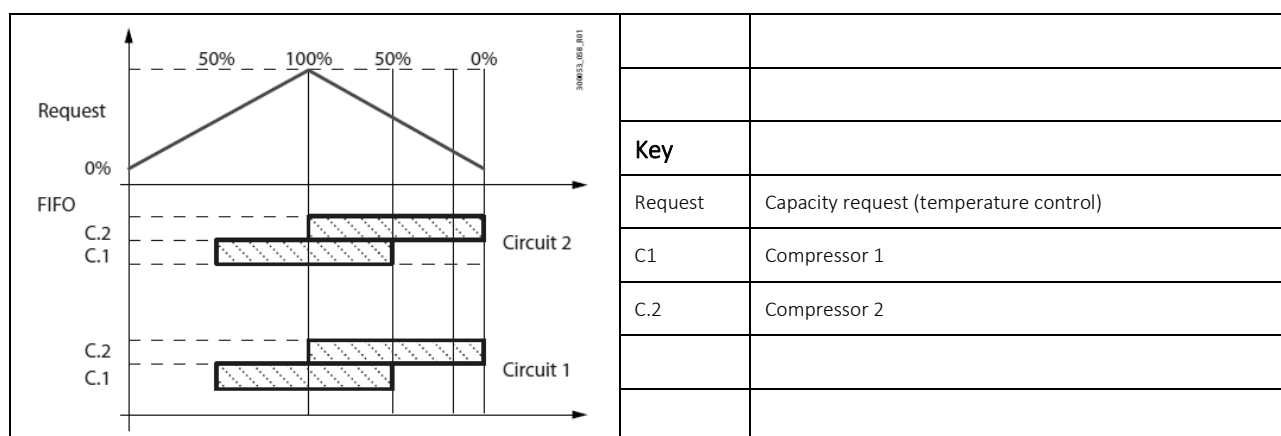

5.4.3 Rotation due to alarm

In the event of a compressor alarm, the next compressor available will be switched on as a replacement if the temperature control request is sufficiently high as to warrant starting another compressor.

5.4.4 Force rotation (destabilisation)

Some compressor manufacturers specify that on units with multiple compressors, the compressors need to be rotated after a certain period of inactivity, even if control is stable.

The destabilisation function, which meets this requirement:

- can be enabled by parameter;
- avoids refrigerant migration during long periods of inactivity;
- can also be used to keep all the compressors at operating temperature.

User	Code	Description	Def.	Min.	Max.	Uom
M	C020	Maximum circuit destabilisation time	240	5	999	min
M	C044	Enable destabilisation – 0/1= No/Yes	1	0	1	-

5.5 Compressor management

µChiller manages scroll compressors with direct starting or modulating BLDC compressors (scroll and rotary).

A maximum of 4 scroll compressors are available in tandem configuration on two circuits; in the High Efficiency models, with BLDC compressors, the maximum is 1BLDC+1On-Off per circuit.

The flow chart below shows the process for calculating the request to the compressors:

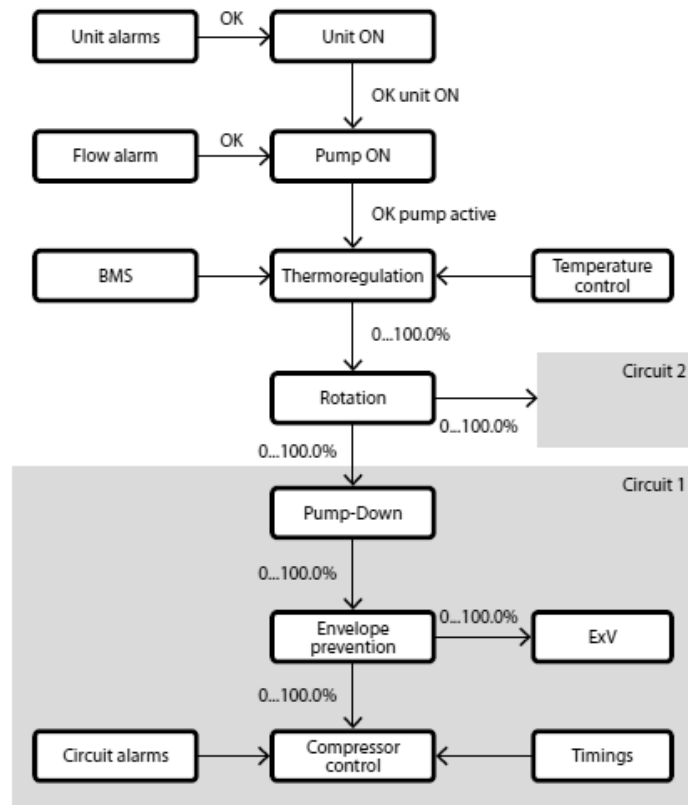

Note: for the sake of simplicity, the parameters are shown for just one compressor and one circuit, therefore all the compressors and circuits on the unit will have the same settings.

5.5.1 Compressors with capacity control (Legacy model only)

For Legacy models, compressors can be capacity-controlled in the compressor plus valve configuration, on a maximum of two circuits. For compressors with capacity control, the FIFO or timed rotation logic will refer to the circuit and not to the compressor valves.

Example: if circuit 1 starts when power returns, compressor 1 starts at part capacity, then the valve is managed as the second step, so that the compressor works at the highest efficiency. If less capacity is needed, first the valve that manages compressor capacity will be deactivated and then the compressor itself. There is no rotation between compressor and valve. When capacity is needed again, the second circuit with compressor 2 will be activated and, subsequently, if required, the corresponding valve. On deactivation, the valve will be managed first, and only then the compressor.

User	Code	Description	Def.	Min.	Max.	Uom
M	F027	Enable capacity-controlled compressor 0/1=No/Yes	0	0	1	-

5.6 Compressor alarms

If abnormal conditions occur and the prevention actions are not effective, the compressor will be shut down so as to avoid damage to the compressor itself or other unit components, i.e. the control algorithm stops the compressors and closes the expansion valve.

Compressor shutdown

The compressors will be available again after the:

- minimum compressor off time (par. C013);
- minimum time between consecutive compressor starts (par. C014).

Compressor delay at start-up/in operation

Compressor start-up is a critical phase. μ Chiller thus manages certain alarms differently, in order to switch smoothly from startup to normal, steady operation. These alarms are:

- low differential pressure;
- out of envelope alarm.

There are thus two delays for these alarms:

- delay at start-up;
- delay in operation.

The alarm condition is ignored when the compressor is off and during the start-up phase. When the unit reaches steady operation, the condition causes the corresponding alarm once the delay has elapsed.

Behaviour will thus be as follows

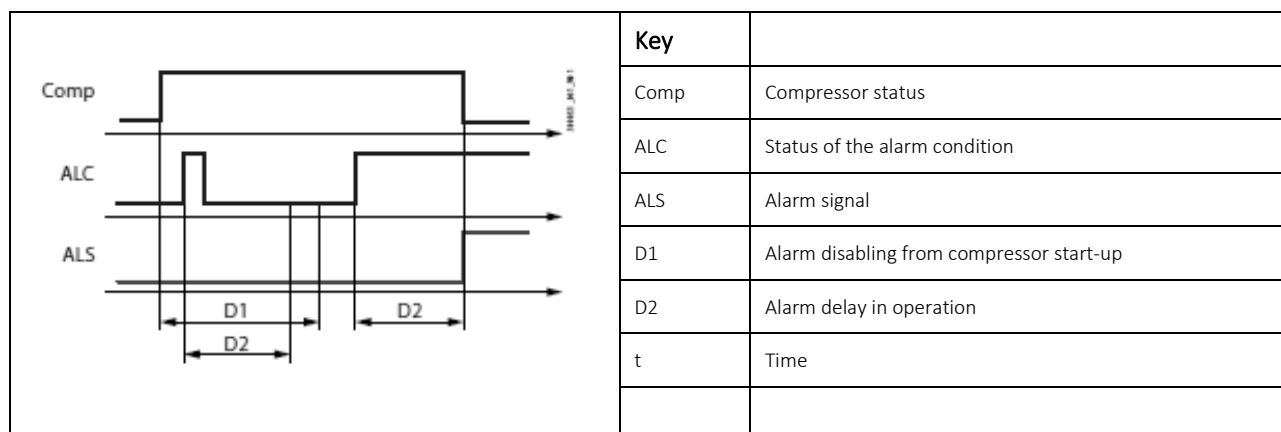

5.7 Expansion valve driver

The driver to manage the electronic expansion valve is a fundamental device for the μ Chiller controller. This is used to safely manage the compressor and thus the circuit, constantly controlling the discharge temperature and the position of the working point inside the compressor envelope. The solution provided manages unipolar valves up to a certain cooling capacity (Carel E3V - cooling capacity up to 90- 100 kW) with the built- in driver (DIN model only) and bipolar valves with higher capacities, using the external EVD Evolution driver. This must be connected to the FBus serial port on μ Chiller via the Modbus circuit 1 protocol

with a baud rate of 19200 bps. Use a specific cable for RS485 (AWG20- 22 with 1½ twisted pair plus shield).



Note:

- EVD Evolution is only used as an expansion valve positioner;
- if the ExV electronic expansion valve is used, the suction temperature probe is connected to input S3 (panel model) or S7(DIN rail model). See the functional diagrams. For the connection see wiring diagram attached to this manual.

5.8 Control of the expansion valve

The control logic manages various functions:

- communication with the EVD Evolution driver, if used (read/write parameters via FBus serial port);
- control of suction superheat (SSH);
- low superheat control and alarm (Low SH);
- minimum evaporation temperature control and alarm (LOP);
- maximum evaporation temperature control and alarm (MOP);
- control of cooling capacity, so as to position the valve correctly in the transient stages according to circuit control status;
- control algorithm that calculates the valve opening steps;
- valve opening value sent to the valve driver.

If the EVD Evolution driver is offline, all the compressors are stopped immediately.

Dedicated electronic expansion valve parameters

- Certain parameters relating to the electronic expansion valve vary according to the operating mode:
- chiller;
- heat pump. These are:
- superheat parameters (set point and PID);
- alarm thresholds and integral actions for protection functions: LOP, MOP and Low SH

5.9 Source pump

µChiller manages one source-side pump (water/water units only). In the same way as for the user pumps, the source pump is activated when the unit is switched on, and a shutdown delay after the last compressor stops can be set.

The source pump can be activated:

- when the unit is switched on, and after a set delay for switching off after the unit has been switched off;
- when the first compressor starts, and after a set delay for switching off after the last compressor stops;
- via temperature control. Below is a table summarising the probes used for controlling the pump in each configuration:

Circuit	Probes used for control	
	Chiller	Heat pump
1	Condensing press./temp.circuit1	Evaporation press./temp. circuit 1
2	Condensing press./temp. circuit 2	Evaporation press./temp. circuit 2

µChiller manages:

- frost protection with the unit off: the pump is started so as to activate fluid circulation (when the unit is on the function is disabled).
- pump anti-blocking: if the pump is off for more than a week, it is activated for 3 seconds

Use	Cod	Description	Def	Min	Max	U
S	S072	Source pump activation - 0=Always on - 1= On with compressor on - 2 = Control on condensing press./temp.	0	0	2	-
S	S028	Source pump in cooling: set point	30.0	-999.9	999.9	°C
S	S029	Source pump in heating: set point	10.0	0.0	99.9	°C
S	S034	Source pump: differential in cooling	15.0	0.0	99.9	K
S	S035	Source pump: differential in heating	5.0	0.0	99.9	K

5.10 Source fans

On units with two circuits, µChiller manages the source (condenser) either separately (independent air circuits) or with one common air circuit, by setting a parameter: when there is a common air circuit, fan 1 works based on the higher request between circuit 1 and 2.

Use	Cod	Description	Def	Min	Max	UOM
S	S064	Type of source air circuit - 0 = Independent 1 = Common	0	0	1	-

Below is a table summarising the probes used for controlling the fans in each configuration:

Circuit	Probes used for control	
	Chiller	Heat pump
1	Condensing press./temp.circuit 1	Evaporation press./temp. circuit 1
2	Condensing press./temp. circuit 2	Evaporation press./temp. circuit 2

The control mode changes based on the operating mode (chiller or heat pump).

5.10.1 Modulating / On-Off fans

On the µChiller panel version, analogue output Y1 is the only output available: consequently, to control an on-off fan, a CONV-ON OFF module (Carel) is needed to convert the 0-10 V analogue output into a relay control. On the versions for DIN rail mounting, relay NO6 is available and can be configured as a fan output. On-Off fans then need to be configured.

Use	Code	Description	Def	Min	Max	UOM
M	Hc12	NO6 configuration - 0=Frost protection 1=Source fan/pump	0	0	1	-
S	S065	Type of source fan 0/1=Modulating/ON-OFF	0	0	1	-
S	S028	Source fan in cooling: set point	30.0	-999.9	999.9	°C
S	S029	Source fan in heating: set point	10.0	0.0	99.9	°C
S	S031	Source fan in cooling: set point at start-up	45.0	0.0	999.9	°C
S	S032	Source fan: delay at start-up in cooling	240	0	999	s
S	S034	Source fan: differential in cooling	15.0	0.0	99.9	K
S	S035	Source fan: differential in heating	5.0	0.0	99.9	K
S	S036	Modulating source fan: min speed value	20.0	0.0	100.0	%
S	S037	Modulating source fan: max speed value	80.0	0.0	100.0	%

The following diagram shows the two control modes (modulating or on-off) in chiller operation (cooling):

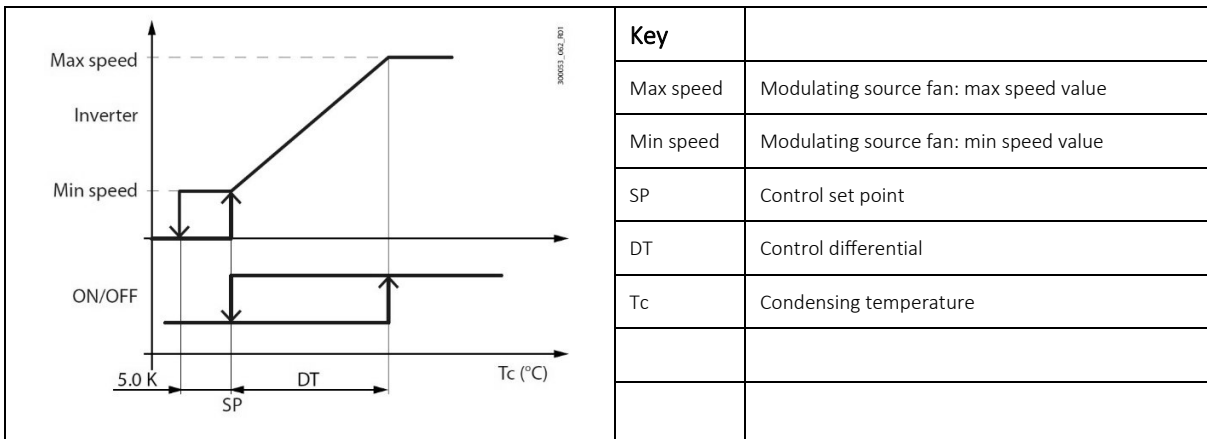

5.10.2 Control in chiller mode

Fan control may be modulating or ON-OFF and is based on the saturated temperature value, equivalent to the condensing pressure, limited by Tc max.

Use	Code	Description	Def	Min	Max	UOM
S	C017	Max high pressure threshold (HP)	65.0	0.0	999.9	°C
S	S028	Source fan in cooling: set point	30.0	-999.9	999.9	°C
S	S034	Source fan: differential in cooling	15.0	0.0	99.9	K
S	S036	Modulating source fan: min speed value	20.0	0.0	100.0	%
S	S037	Modulating source fan: max speed value	80.0	0.0	100.0	%

The control diagram is shown below:

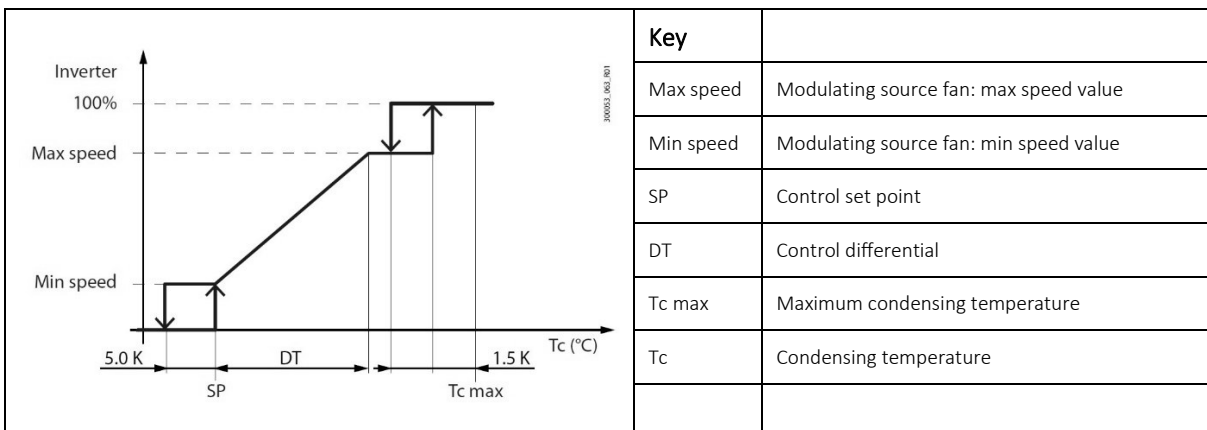

Fig.5.r

In the graph, some offsets are expressed with a numerical value, indicating that they are not modifiable but rather are fixed parameters. The current calculated set point value is displayed on the dashboard.

Set point control

In chiller mode, a specific condensing temperature set point for starting the compressor can be set to a value that is higher than the nominal set point, so that the compressor can reach steady operation more quickly.

The transition to the nominal set point is made gradually over a time equal to the delay at start-up.

Use	Cod	Description	Def	Min	Max	UOM
S	S031	Source fan in cooling: set point at start-up	45.0	0.0	999.9	°C
S	S032	Source fan: delay at start-up in cooling	240.0	0	999	°C

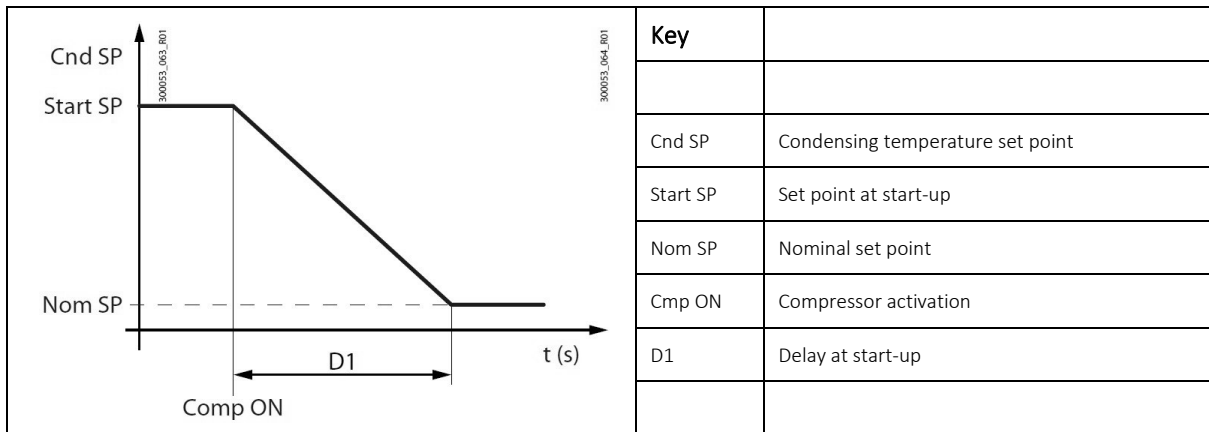

5.10.3 Control in heat pump mode

Fan control may be modulating or ON-OFF and is based on the saturated temperature value, equivalent to the evaporation pressure.

Use	Cod	Description	Def	Min	Max	UOM
S	C017	Max high pressure threshold (HP)	65.0	0.0	999.9	°C
S	S029	Source fan in heating: set point	10.0	-999.9	999.9	°C
S	S035	Source fan: differential in heating	5.0	0.0	99.9	K
S	S036	Modulating source fan: min speed value	20.0	0.0	100.0	%
S	S037	Modulating source fan: max speed value	80.0	0.0	100.0	%

The control diagram is shown below:

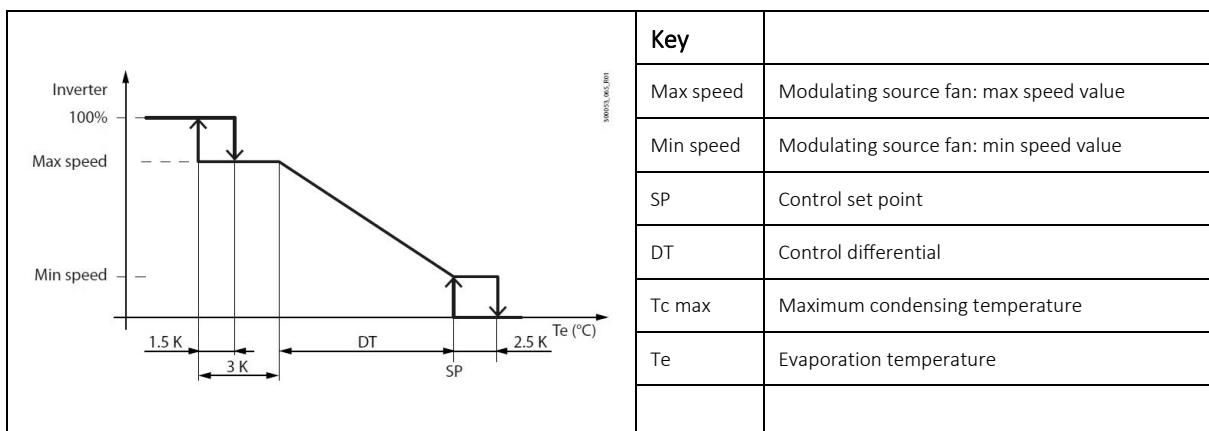

In the graph, some off sets are expressed with a numerical value, indicating that they are not modifiable on the display but rather are fixed parameters. The current calculated set point value is displayed on the dashboard.



5.10.4 “Low noise” function

This function reduces the noise emitted by modulating fans by increasing the set point at night.

Use	Cod	Description	Def	Min	Max	UOM
S	S020	Enable noise reduction 0/1=No/Yes	0	0	1	-
S	S021	Noise reduction time band: start hours	22	0	23	h
S	S022	Noise reduction time band: start minutes	30	0	59	min
S	S023	Noise reduction time band: end hours	8	0	23	h
S	S024	Noise reduction time band: end minutes	30	0	59	min
S	S025	Source fan: noise reduction set point	45.	0.0	999.9	°C

5.10.5 Fan anti-blocking function

For systems intended to operate in cold climates, μ Chiller modulates fan speed to prevent the unit from shutting down due to frost formation. The function is activated when the outdoor temperature falls below a threshold and, instead of turning off the fans, keeps them on at a minimum speed. If the outside temperature is reached when the fans are off, these are activated at start-up speed for a certain time, and then switch to the minimum speed.

Use	Cod	Description	Def	Min	Max	UOM
S	S016	Source fan: cold climate temperature threshold	-0.5	-999.9	999.9	°C
S	S017	Source fan: min cold climate speed	10.0	0.0	100.0	%
S	S018	Source fan: cold climate speed at start-up	50.0	0.0	100.0	%
S	S019	Source fan: cold climate speed at start-up time	5	0	300	s

5.11 Free cooling

The free cooling (FC) function can be enabled only on chiller units. The type of free cooling is configured by parameter, and may be:

- air free cooling, on air/water units equipped with air- water heat exchanger coils upstream of the condenser coils and with modulating fan control;
- remote air free cooling (see the specific paragraph);
- water free cooling, on water/water units with mixing of the source water or via water- water heat exchanger upstream of the evaporator and a 3-way modulating valve on the free cooling circuit.

Use	Cod	Description	Def	Min	Max	UOM
S	U068	Free cooling: enable 0/1=no/yes	0	0	1	-
S	U069	Free cooling: activation differential	3.0	0.0	99.9	K
S	U070	Free cooling: hysteresis	1.5	0.0	99.9	K
S	U071	Design free cooling delta T	8.0	0.0	99.9	K
S	U072	Water free cooling: valve closing threshold	5.0	-999.9	999.9	°C
S	U073	Water free cooling: valve closing differential	3.0	0.0	99.9	K
M	U074	Free cooling type: 0=Air 1=Remote coil 2=Water	0	0	2	-

Free cooling is enabled when the outside source temperature is sufficiently lower than the temperature of the water entering the unit, as shown in the following figure:

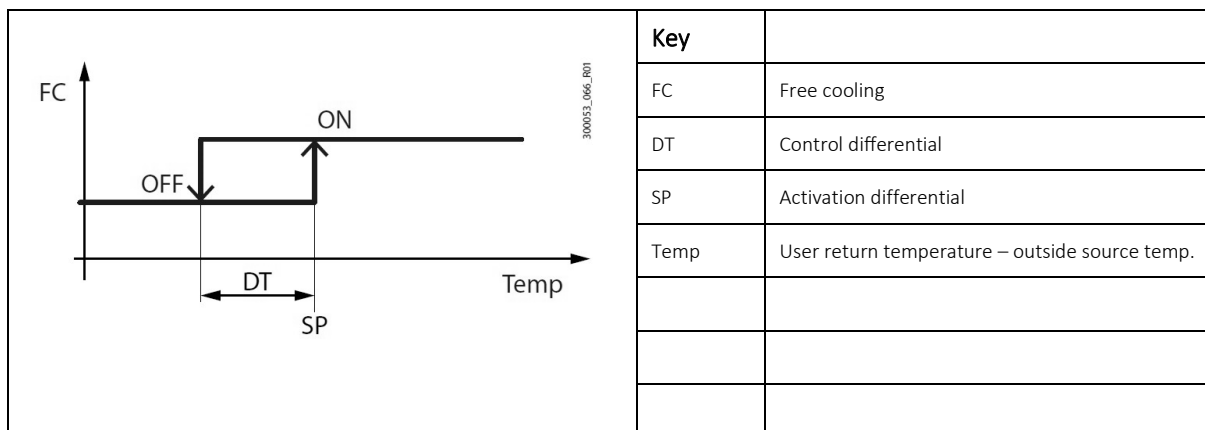

On air/water units, the fans are controlled based on the condensing temperature as long as the circuit's compressor is on; as soon as the compressor stops, the free cooling fan is controlled to maintain the desired water temperature set point.

5.12 Types of free cooling

5.12.1 Condensing unit with common air circuit

Free cooling is enabled based on the comparison between the user return water temperature and the outside air temperature; this directly controls switching of the three-way valve, which allows the water returning from the user terminals to flow through the free cooling coil before entering the evaporator. Free cooling capacity is controlled by modulating the fan speed (with the compressors off); in combined operation (free cooling + mechanical cooling), fan speed is controlled to correctly manage the condensing stage.

Inputs used:

To enable free cooling:

- User return temperature;
- Outside air temperature;

To manage capacity in free cooling mode:

- (according to the control probe used) Return/delivery water temperature.

Outputs used:

- 0-10 V to manage the common fan between free cooling and condenser;
- Free cooling valve On-Off control

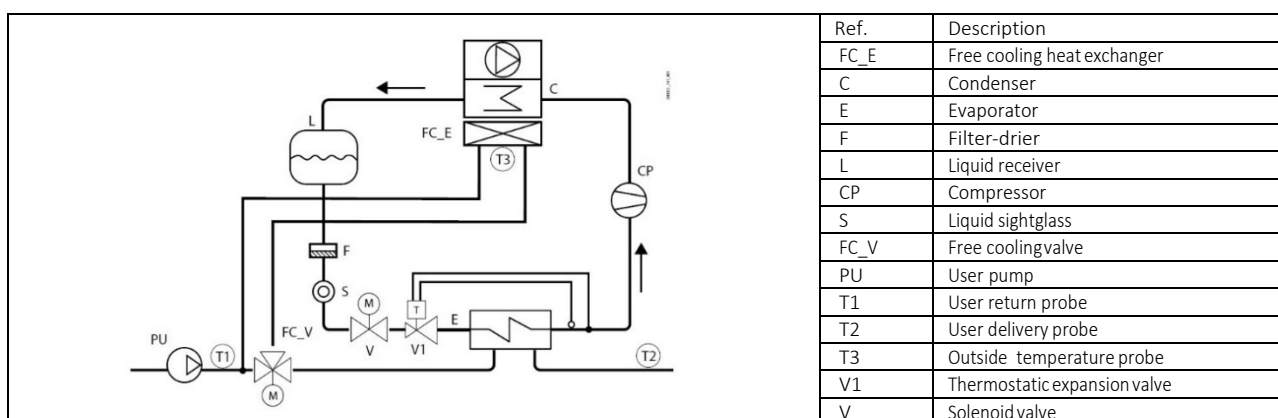

5.12.2 Air-cooled condensing unit with separate air circuit

Free cooling is enabled based on the comparison between the user return water temperature and the outside air temperature; this directly controls switching of the three-way valve, which allows the water returning from the user terminals to flow through the free cooling coil before entering the evaporator. Free cooling capacity is controlled by modulating the specific fan speed; in combined operation (free cooling + mechanical cooling), free cooling fan speed is always 100%.

Inputs used:

To enable free cooling:

- User return temperature;
- Outside air temperature;

To manage capacity in free cooling mode:

- (according to the control probe used) Return/delivery water temp.

Outputs used:

- 0-10 V to manage the condenser fan (Y1: Circuit 1 and Circuit 2)
- 0-10 V to manage the free cooling fan (Y2: Circuit 1);
- Free cooling valve On-Off control.

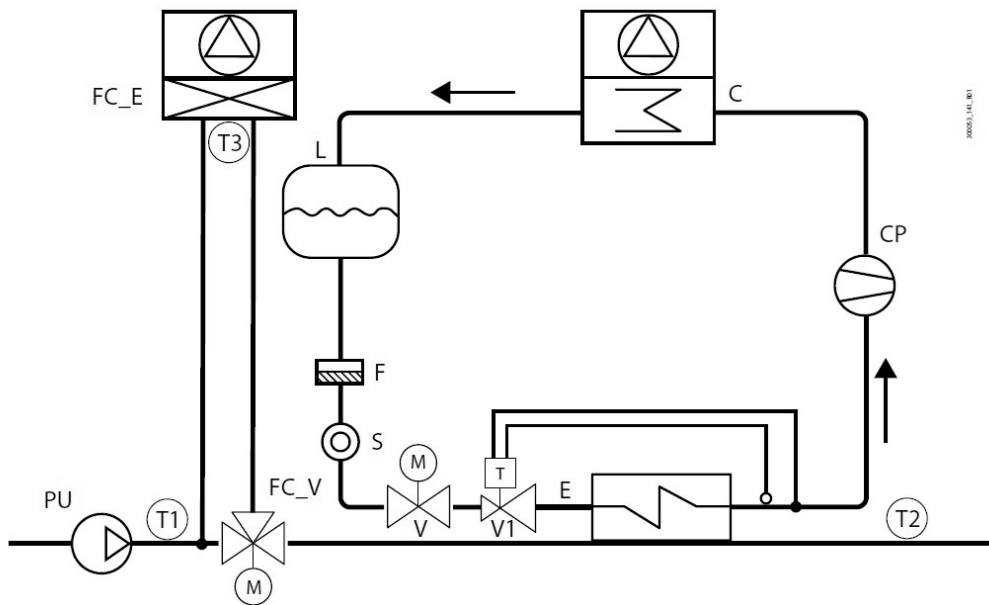

Ref.	Description
FC_E	Free cooling heat exchanger
C	Condenser
E	Evaporator
F	Filter-drier
L	Liquid receiver
CP	Compressor
S	Liquid sight glass

Ref.	Description
FC_V	Free cooling valve
PU	User pump
T1	User return probe
T2	User delivery probe
T3	Outside temperature probe
V1	Thermostatic expansion valve
V	Solenoid valve

5.12.3 Water-cooled condensing unit

Free cooling is enabled based on the comparison between the user return water temperature and the source water temperature (Temp. IN source); this controls modulation of the three-way valve that mixes the source water with the water returning from the user terminals through the free cooling coil before entering the evaporator.

Free cooling capacity is controlled by modulating the three-way free cooling valve; in combined operation (free cooling + mechanical cooling), the three-way free cooling valve is always open at 100%.

Inputs used:

To enable free cooling:

- User return temperature;
- Source inlet temperature;

To manage capacity in free cooling mode:

- (according to the control probe used) Return/delivery water temp.

Outputs used:

- 0-10 V to manage the condenser fan
- 0-10 V to manage the free cooling valve

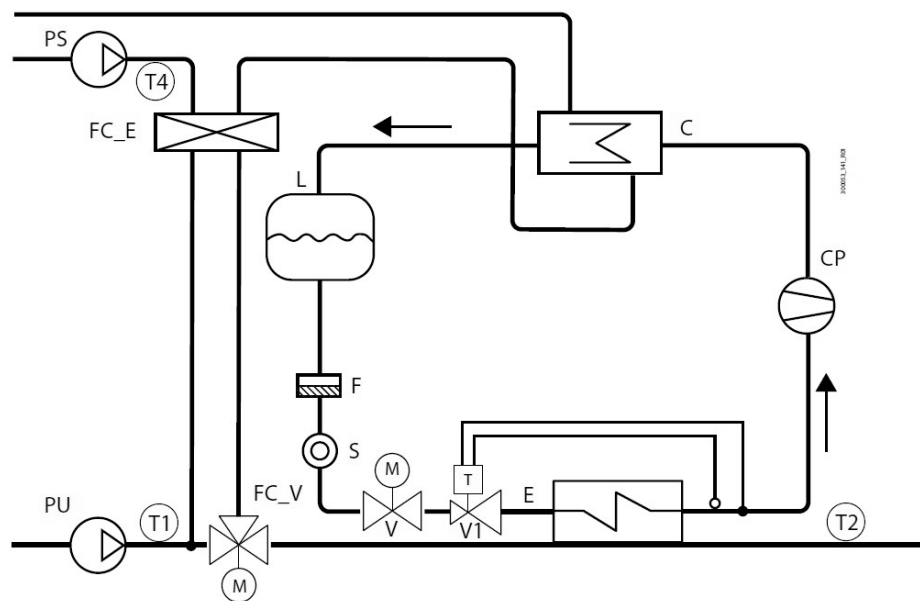

Ref.	Description
FC_E	Free cooling heat exchanger
C	Condenser
E	Evaporator
F	Filter-drier
L	Liquid receiver
CP	Compressor
FC_E	Free cooling heat exchanger
S	Liquid sightglass

Ref.	Description
V	Solenoid valve
FC_V	Free cooling valve
PU	User pump
PS	Source pump
T1	User return probe
T2	User delivery probe
T4	Source return probe
V1	Thermostatic expansion valve

5.13 Free cooling functions

5.13.1 Dynamic control gain

This special function manages the balancing of capacity between the free cooling coil and the evaporator: this optimises control stability and fluidity.

Use	Cod	Description	Def	Min	Max	UOM
S	U070	Free cooling: hysteresis	1.5	0.0	99.9	K
S	U069	Free cooling: activation differential	3.0	0.0	99.9	K
S	U071	Free cooling delta T	8.0	0.0	99.9	K

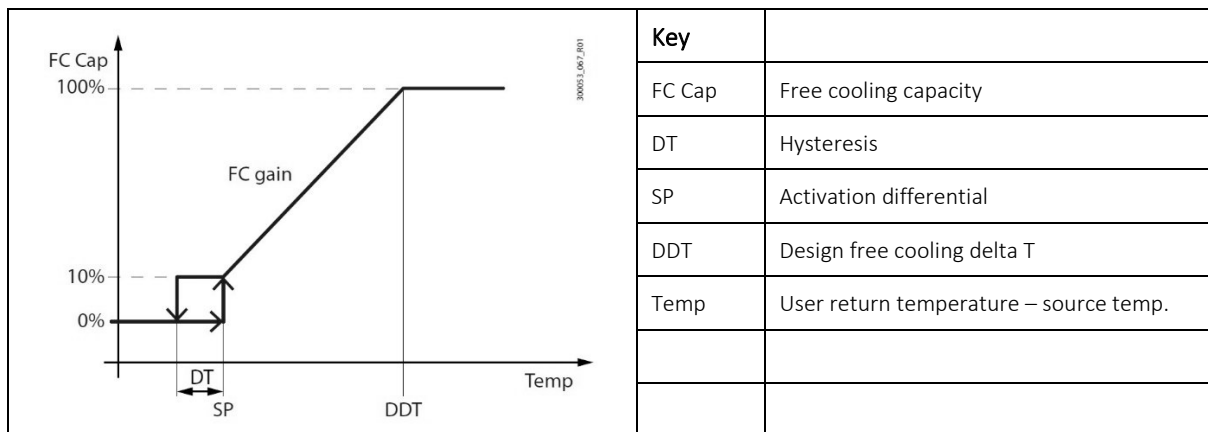

Fig.5.y

The diagram shows the ideal behaviour of free cooling control (FC) in relation proportionally to its capacity; "Design free cooling delta T" is the temperature difference (water inlet - source) needed to cover the rated unit capacity using the free cooling coil only.

The value obtained - "FC gain" - is used to adapt the control ramp to the various cooling sources, as shown in the figure.

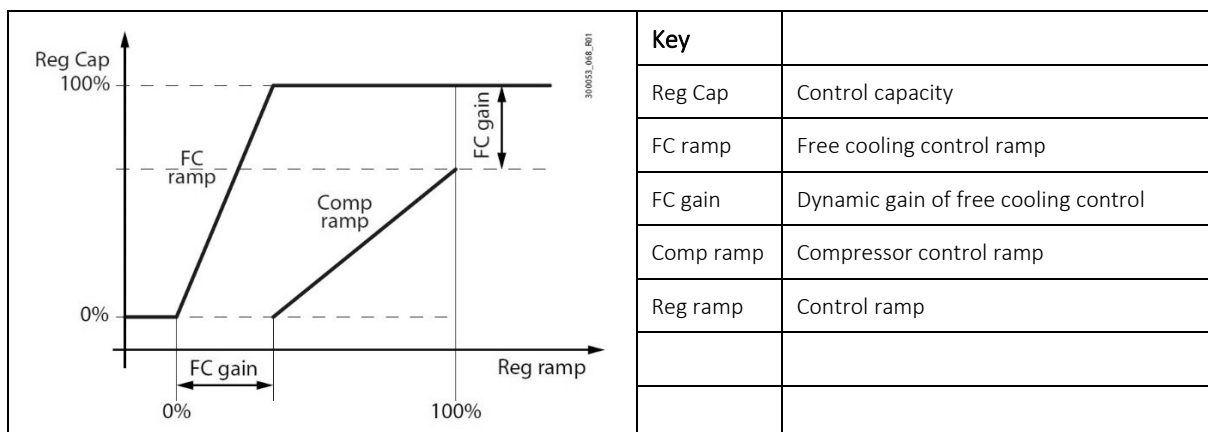

Fig.5.z

The result is a perfect balance between the cooling capacities of the free cooling coil and the evaporator, in order to maintain the same proportionality in all load conditions. In other words, the same percentage of capacity is obtained for the same temperature variation in any load condition.

5.13.2 Effectiveness control

μChiller uses this function to start the compressors when the free cooling coil alone cannot bring the water to the set point, despite the fact that the source conditions theoretically allow for free cooling operation only. When this occurs, there may be a malfunction on the devices activated during free cooling; the compressors thus need to be started and free cooling disabled in order to ensure unit operation.

This situation is signalled by the "Free cooling warning".

5.13.3 Valve anti-block management

To avoid mechanical blocking of the valve, when a position (closed or open) is kept for more than a week, the valve is moved for 30 seconds to the opposite position.

5.14 Defrost

During heat pump operation on air/water units, the outdoor coil works as an evaporator. If the outside temperature is low, frost may form on the coil, resulting in reduced unit efficiency. To free the coil from frost and restore maximum efficiency, μChiller activates the defrost function. Activation depends on the value read by the reference probe (pressure transducer, low pressure side -> evaporation temperature in the graph), on the activation threshold being exceeded, and a possible delay.

Use	Cod	Description	Def	Min	Max	UOM
S	S039	Defrost: start temperature	-1.0	-99.9	99.0	°C
S	S040	Defrost: reset start defrost delay threshold	1.0	S039	99.9	°C
S	S041	Defrost: delay at start-up	30	0	999	min
S	S042	Defrost: end temperature	52.0	-999.9	999.9	°C
S	S046	Defrost: min duration	1	0	99	min
S	S047	Defrost: max duration	5	0	99	min

Example of defrost activation:

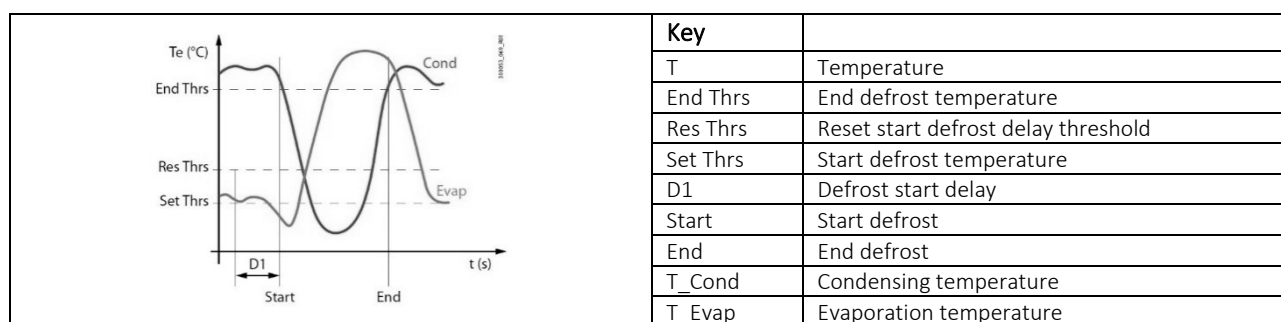

Fig.5.aa

If the defrost temperature does not exceed the reset threshold during the defrost start delay, then the defrost starts. It ends when the reference probe (pressure transducer, high pressure side -> condensing temperature in the graph) exceeds the end defrost temperature or the maximum defrost duration has elapsed.

Note: for optimal defrost management, it is recommended to set the start defrost temperature to the evaporation temperature value at which ice starts forming on the coil (-1.0°C / -1.5°C); the defrost start delay expresses the time needed to accumulate a layer of ice that requires defrosting (30- 60 minutes). Also see the paragraph "Sliding defrost".

5.14.1 Defrost procedure

Note: in the following description:

- "case with compressor ON" indicates that the phase is only featured if defrost is set with the compressor On;
- "case with compressor off " indicates that the phase is only featured if defrost is set with the compressor Off;

End defrost can be managed in two ways:

- with the compressor off: the thermal inertia of the condenser is used to end the defrost;
- with the compressor on: to make the defrost as fast as possible.

Use	Cod	Description	De	Mi	M	UO
M	S055	Compressor after defrost 0/1=On/Off	0	0	1	-

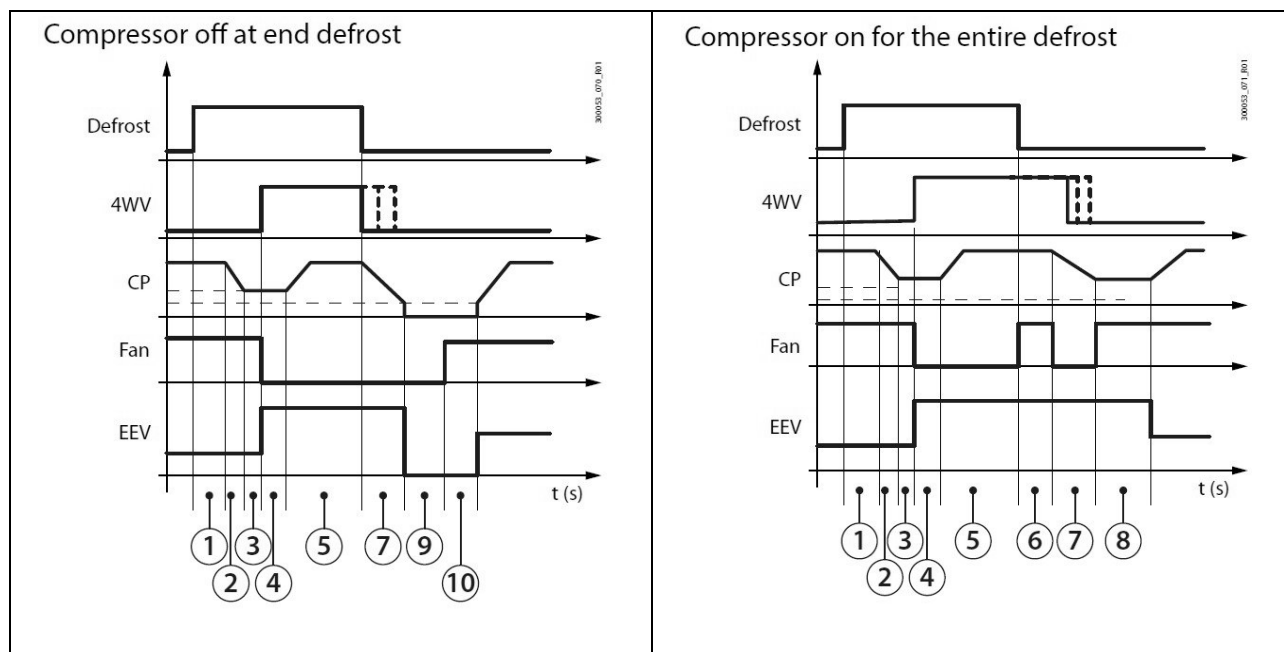

Key	
Defrost	Defrost request
4WV	Cycle reversal (4-way valve)
CP	Compressor capacity
Fan	Enable fans
EEV	Electronic expansion valve



The control phases are described below.

Synchronisation (1)

Once the defrost start condition is true, there is a fixed delay of 10 s to check whether the other circuit requires defrosting, to carry out a simultaneous defrost if needed.

Use	Cod	Description	Def	Min	Max	UOM
s	S053	Defrost synchronisation: 0=Independent 1=Separate 2=Simultaneous	40.0	0.0	999.9	rps

Decrease capacity to start defrosting (2)

Capacity at start defrost can be managed in two ways:

- stopping the compressors
- compressor running at minimum power. For circuits with on-off compressors, a single compressor kept on, while the compressor is kept at minimum capacity for circuits with BLDC compressor.

Use	Cod	Description	Def	Min	Max	UOM
M	S073	Compressor status at start defrost 0/1=On/Off	0	0	1	-
s	S052	BLDC compressor speed for cycle reversing in defrost	40.0	0.0	999.9	rps

Waiting time before reversing the cycle (3)

The 4-way valve is positioned in chiller mode to run the defrost, the fans are stopped and the compressor remains at the cycle-reversal speed for 5 seconds. Normally during this phase the electronic expansion valve tends to close, due to low superheat. As a result it is forced to the maximum opening so as to guarantee a constant flow of refrigerant and maximum defrost capacity.

Use	Cod	Description	Def	Min	Max	UOM
s	S044	Operation time at min capacity before cycle reversing	20	0	999	s

Cycle reversal and waiting time after reversal (4)

The 4-way valve is positioned in chiller mode to perform defrost, the fans switch off and the compressor remains at the cycle inversion speed for 5 seconds. Normally during this phase the electronic expansion valve tends to close due to low superheat. For this reason it is forced to the maximum opening to guarantee the constant flow of refrigerant and the maximum defrost power.

Defrosting (5)

The actual defrosting procedure starts: the compressor delivers full capacity so as to defrost the outdoor coil. In this phase, the BLDC compressor goes to the speed set by the corresponding parameter, the electronic expansion valve remains at the maximum opening and the fans remain off. The minimum/maximum defrost time and minimum time between two consecutive defrosts start counting in this phase.

Use	Cod	Description	Def	Min	Max	UOM
s	S046	Defrost: min duration	1	0	99	min
s	S047	Defrost: max duration	5	0	99	min
s	S050	Minimum delay between consecutive defrosts	20	0	999	min
s	S051	BLDC compressor speed in defrost	80.0	0.0	999.9	rps

The minimum defrost time protects compressors and circuit components from transients with high dynamics that are too close together. The maximum defrost time is a safety feature that avoids any abnormal conditions (end defrost threshold not reached - e.g. due to strong winds) that would stop the production of hot water required by the user terminals. The minimum time between consecutive defrosts is needed to prevent the unit from defrosting too frequently and thus only partly meeting demand. The actual defrosting procedure therefore ends after a maximum time or when the set condensing temperature is reached. If the compressor stops during this phase, the counters are reset.



Dripping (case with compressor on) (6)

In this phase, the compressor remains on at the defrost speed, the electronic valve is opened to the maximum and the fans are started at maximum speed, and remain at this speed for the entire dripping phase. The duration of the dripping phase can be set.

Use	Code	Description	Def	Min	Max	UOM
s	S048	Dripping: duration	90	0	999	s

Decreased compressor capacity to end defrost (7)

Circuit capacity is reduced to the minimum and the cycle is reversed. In this phase, the fans are stopped (they are only activated if necessary for high pressure prevention) and the cycle reversing valve is moved to the heat pump position, controlled based on the difference between condensation and evaporation pressure: as soon as this pressure difference falls below the minimum differential for valve activation + 1 bar, the cycle is reversed (return to heat pump mode). If the reversing threshold is not reached, the cycle is reversed after a fixed time (60 s). The electronic expansion valve is opened to the maximum position.

Use	Code	Description	Def	Min	Max	UOM
s	S054	4-way valve: pressure differential for reversing	3.0	0.0	999.9	bar

Waiting after cycle reversal (case with comp. ON) (8)

After reversing the cycle, there is a waiting time to ensure the correct flow of refrigerant; in this phase too, the ExV remains in the 100% open position.

Use	Code	Description	Def	Min	Max	UOM
s	S045	Operation time at min capacity after cycle reversing	30	0.0	999.9	s

Dripping (case with comp. OFF) (9)

In this phase, the compressors, the electronic expansion valve and the fans are stopped, waiting for the coil to complete defrosting due to thermal inertia and stop dripping. The duration of the dripping phase can be set.

Use	Code	Description	Def	Min	Max	UOM
s	S0478	Dripping: duration - 0=Dripping not performed	90	0	999	s

Post-dripping phase (case with comp. OFF) (10)

During this phase, the fans are started at 100% speed to completely expel any water still on the coil. The duration of the post- dripping phase can be set. At the end of the post- dripping phase, the circuit is reactivated in normal heat pump operation.

Use	Code	Description	De	Min	Max	UOM
s	S049	Post-dripping: duration - 0=Post-dripping not performed	30.0	0	999	s

Quick start phase (case with comp. OFF) (11)

The compressor restarts based on the control request and the unit returns to normal operation. The start- up time is reduced so as to quickly bring compressor speed in line with the request.

Use	Code	Description	Def	Min	Max	UOM
s	S056	BLDC smart start: duration (*)	30.0	0	999	s

(*) Shortened compressor start-up after defrost

This action assumes that the compressor has been off for a very short time, and therefore does not require complete pre-heating as is the case during normal start-up.

During the defrost phase (when the unit is in chiller mode), the fans are started if the condensing pressure exceeds the high condensing pressure alarm threshold - 5K.

Use	Code	Description	Def	Min	Max	UOM
M	C017	Max high pressure threshold (HP)	30.0	0	999	s

5.14.2 Defrost with fans

When the outside temperature allows (outside temperature > 6-7°C), the fans alone can be used to defrost the coil, without operating the compressors, so as to improve system energy efficiency. When the outside temperature is greater than or equal to the value of S069, the function is activated: in this condition, the waiting time S041 before the defrost request is halved (to facilitate defrosting with fans only).



Note: if parameter S069 is set to 0.0°C (32°F), the function is disabled.

User	Code	Description	Def	Min	Max	UOM
S	S069	Defrost with fans: outside temperature threshold 0.0=Function disabled	0.0	0.0	99.9	°C

The defrost phases are as follows.

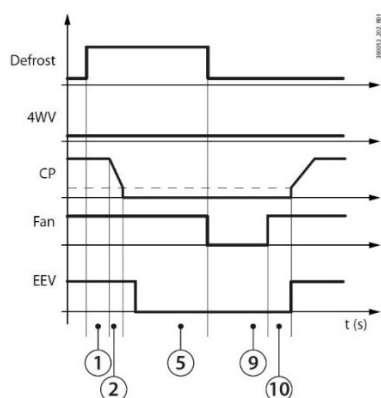

Synchronisation (1):

See the previous defrosts.

Compressor stopped to start defrosting (2)

The circuit with the BLDC compressor decreases its capacity to the minimum set value, and then switches off; on-off compressors are all switched off.

Defrosting (5)

The actual defrosting phase starts: the fans are started at 100% speed to heat the coil and melt the ice that has formed on the fins. Defrosting ends, once the minimum time has elapsed, when the evaporation temperature reaches 2°C, or after the maximum time. The minimum/maximum defrost time and minimum time between two consecutive defrosts start counting in this phase.

Dripping (9)

The fans are stopped, waiting for the coil to complete defrosting due to thermal inertia and stop dripping. The dripping time can be set.

Post-dripping (10)

The fans are started at 100% speed to completely expel any water still on the coil. The post-dripping time can be set. At the end of the post-dripping phase, the circuit is reactivated in normal heat pump operation.

5.14.3 Sliding defrost

As the water vapour content in the air decreases as the outside temperature decreases, the time needed for a layer of ice to form that requires defrosting increases proportionally as the outside temperature decreases. Consequently, a function has been added, enabled when the outside air probe is available, which extends the defrost delay time, as shown in the following figure.



Note: the outside probe can be connected to inputs S3/S6 (setting: external temperature)

User	Code	Description	Def	Min	Max	UOM
M	Hc00	S3 configuration 0=Not used 1=External temp. 2=Discharge temp. 3=Suction temp. 4=Source water delivery temperature	0	0	3/4	-
M	Hc03	S6 configuration 0=Not used 1=Remote set point 2=External temperature	0	0	2	-
S	S041	Defrost: delay at start-up	30	0	999	min
S	S043	Enable sliding defrost: 0/1=No/Yes	0	0	1	-

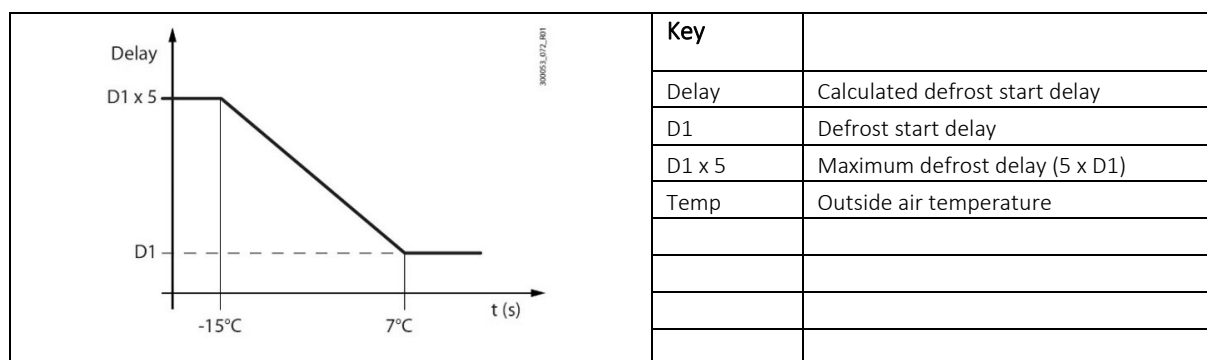

5.14.4 Defrost synchronisation

On two-circuit units, the defrosting procedures can be synchronised.

Use	Cod	Description	Def	Min	Max	UOM
S	S053	Defrost synchronisation 0=Independent 1=Separate 2=Simultaneous	0	0	2	-

Independent

The two circuits start defrosting when the conditions are right, independently of each other. In other words, there is no synchronization and the circuits can defrost at the same time.

Separate

When the first circuit requires defrosting:

- it start the defrost procedure;
- the other continues to work in heat pump mode;

When the first circuit has finished defrosting, the other is free to start.

Simultaneous

This procedure is used if the air flow cooling the condenser coils on one circuit affects the other: during the defrost phase this would mean a considerable waste of energy to recover the heat lost in the air flow on the other circuit. The first circuit that requires defrosting thus puts the entire unit into defrost mode. If only one circuit starts defrosting, it completes all the defrost phases while the other remains off. If the other circuit one requires defrosting but is waiting until the defrost start delay elapses, the delay is ignored and the circuit also starts defrosting. When one of the circuits reaches the end defrost condition, it remains in the dripping phase until the other circuit ends the procedure. In this way, the dripping phase is performed by both circuits, preventing the air flow to the condenser coils from affecting the defrost procedure. During this phase, the compressor is stopped instead of operating at end defrost capacity, to prevent the waiting phase of the other compressor from bringing the user terminals to excessively low temperatures.



Note: if there is a common air circuit for the condensers, simultaneous defrosting is enabled automatically.

5.15 4-way valve management

A special function has been included to ensure correct control of the 4-way valve that reverses the refrigerating cycle. When there is a request to reverse the valve, the controller checks whether the pressure difference is higher than a threshold before activating the valve: if the difference is lower, the application waits until the compressor starts and then activates the valve when the pressure difference is reached.

Use	Cod	Description	Def	Min	Max	UOM
M	S054	4-way valve: pressure differential for reversing	3.0	0.0	999.9	bar

In the event of a power failure, the controller realigns the 4-way valve with the physical position of the valve at next start-up, considering the status of the circuit at the time of the power failure.

5.16 Condensing unit management

µChiller can manage condensing units with one or two circuits, air- or water-cooled, in cooling-only mode or reverse cycle with defrost. The mode is set using parameter U077.

Compared to a chiller unit, the condensing unit does not manage circulation of the primary fluid (pump, flow switch, etc.).

The control signal can be sent to the condensing unit in two ways:

- via BMS;
- via digital inputs

Request via BMS

The request is written by an external device to register HR 331. If the unit is offline, the request is overridden to 0% and the devices are turned off.



Request via digital inputs

There is a digital input for each compressor. Activation of the digital input corresponds to a control step request. The μ Chiller application manages rotation between steps, stop due to alarms, and timings.

For Legacy models only, the direct relationship between request digital inputs and compressor digital outputs can be set using parameter F023. In this case, rotation of the steps must be managed externally.

Use	Code	Description	Def	Min	Max	UOM
S	F023	Direct relationship DI - compressor DO (MC only) 0=No, 1=Yes	0	0	1	-

6. PARAMETER TABLE

Notes:

- Levels: U=User; S=Service; M=Manufacturer; Display: the x indicates that the parameter can be accessed from the display terminal;
- R/W=read/write parameters; R=read-only parameters.

6.1 System

User	Display	Code	Description	Def	Min	Max	UOM	R/W	Modbus
Plt = System									
S		U000	User pump 1: maintenance hour threshold (x100)	99	0	999	h	R/W	HR002
S		U001	User pump 1: reset hour counter	0	0	1	-	R/W	CS000
S	x	U002	User pump 1: operating mode 0=AUTO - 1=OFF - 2=ON	0	0	2	-	R/W	HR003
S		U003	User pump 2: maintenance hour threshold (x100)	99	0	999	h	R/W	HR004
S		U004	User pump 2: reset hour counter	0	0	1	-	R/W	CS001
S	x	U005	User pump 2: operating mode 0=AUTO - 1=OFF - 2=ON	0	0	2	-	R/W	HR005
S		U006	Cooling set point: minimum limit	5.0	-99.9	999.9	°C/°F	R/W	HR007 (2R)
S		U007	Cooling set point: maximum limit	20.0	-99.9	999.9	°C/°F	R/W	HR009 (2R)
S		U008	Heating set point: minimum limit	30.0	0.0	999.9	°C/°F	R/W	HR01 (2R)
S		U009	Heating set point: maximum limit	45.0	0.0	999.9	°C/°F	R/W	HR011 (2R)
S		U010	Enable set point compensation - 0/1=no/yes	0	0	1	-	R/W	CS002
S		U011	Cooling compensation: start	25.0	-99.9	999.9	°C/°F	R/W	HR015 (2R)
S		U012	Cooling compensation: end	35.0	-99.9	999.9	°C/°F	R/W	HR017 (2R)
S		U013	Cooling compensation: maximum value	5.0	-99.9	999.9	K/R	R/W	HR019 (2R)
S		U014	Heating compensation: start	5.0	-99.9	999.9	°C/°F	R/W	HR021 (2R)
S		U015	Heating compensation: end	-10	-99.9	999.9	°C/°F	R/W	HR023 (2R)
S		U016	Heating compensation: maximum value	5.0	-99.9	999.9	K/R	R/W	HR025 (2R)
S		U017	Enable time band - 0/1=No/Yes	0	0	1	-	R/W	CS003
S		U018	Time band: start hours	17	0	23	h	R/W	HR027
S		U019	Time band: start minutes	30	0	59	min	R/W	HR028
S		U020	Time band: end hours	7	0	23	h	R/W	HR029
S		U021	Time band: end minutes	0	0	59	min	R/W	HR030
S		U022	Type of changeover in time band 0=Off - 1=2nd set point	0	0	1	-	R/W	CS004
U	x	U023	2nd cooling set point	10.0	U006	U007	°C/°F	R/W	HR031(2R)
U	x	U024	2nd heating set point	35.0	U008	U009	°C/°F	R/W	HR033(2R)
S		U025	Remote set point: analogue input 0=0-5V - 1=0-10V - 2=4-20 mV	0	0	2	-	R/W	HR035
S		U026	Remote set point: min value	5.0	-99.9	999.9	°C/°F	R/W	HR037(2R)
S		U027	Remote set point: max value	35.0	-99.9	99.9	°C/°F	R/W	HR039(2R)
S		U028	Remote set point: offset	0.0	-99.9	99.9	K/R	R/W	HR043(2R)
S	x	U031	High water temp. alarm: offset	10.0	0.0	99.9	K/R	R/W	HR049(2R)
S	x	U032	High water temp. alarm: delay at start-up	15	0	99	min	R/W	HR051
S	x	U033	High water temp. alarm: delay in operation	180	0	999	s	R/W	HR052
S		U034	Operating mode changeover 0=Keypad - 1=Digital input	0	0	1	-	R/W	CS005
S		U035	Cooling/heating changeover: delay	15	0	999	min	R/W	HR053
S		U036	Control probe at start-up 0=Return - 1=Delivery	0	0	1	-	R/W	CS006
S		U037	PID control delay at start-up/operation	180	0	999	s	R/W	HR054
S		U038	Control probe in operation 0=Return - 1=Delivery	1	0	1	-	R/W	CS007
S		U039	PID at start-up: Kp	6.0	0.0	999.9	-	R/W	HR055(2R)
S		U040	PID at start-up: Ti 0: integral action disabled	180	0	999	s	R/W	HR057
S		U041	PID at start-up: Td 0: derivative action disabled	0	0	99	s	R/W	HR058
S		U042	PID in operation: Kp	10.0	0.0	999.9	-	R/W	HR059(2R)
S		U043	PID in operation: Ti 0: integral action disabled	120	0	999	s	R/W	HR061
S		U044	PID in operation: Td 0: derivative action disabled	3	0	99	s	R/W	HR062
S		U045	User pump flow alarm: delay at start-up	10	0	999	s	R/W	HR063
S		U046	User pump flow alarm: delay in operation	3	0	99	s	R/W	HR064
S		U047	Compressor activation delay after user pump	30	0	999	s	R/W	HR065
S		U048	User pump shutdown delay after compressor	180	0	999	s	R/W	HR066
S		U049	User pump rotation time	12	0	999	h	R/W	HR067
S		U050	User side frost protection: alarm threshold	-0.8	-99.9	999.9	°C/°F	R/W	HR068 (2R)
S		U051	User side frost protection: differential	30.0	0.0	999.9	K/R	R/W	HR070 (2R)

User	Disp.	Code	Description	Def	Min.	Max.	UOM	R/W	Modbus
S		U052	User-side frost protection: delay time at 1K	30	0	999	s	R/W	HR072
S		U053	Unit OFF: frost protection set point	4.0	-99.9	999.9	°C/°F	R/W	HR073 (2R)
S		U054	Unit OFF: frost protection differential	2.0	0.0	99.9	K/R	R/W	HR075 (2R)
S		U055	User side return temp. probe: offset	0.0	-99.9	99.9	K/R	R/W	HR079 (2R)
S		U056	User side delivery temp. probe: offset	0.0	-99.9	99.9	K/R	R/W	HR083 (2R)
S		U057	Remote alarm: input logic - 0/1=NC/NO	0	0	1	-	R/W	CS008
S		U058	Cooling/heating input: logic - 0/1=NO/NC	1	0	1	-	R/W	CS009
S	x	U059	Remote ON/OFF: input logic - 0/1=NO/NC	1	0	1	-	R/W	CS010
S		U060	User pump flow switch: input logic - 0/1=NO/NC	0	0	1	-	R/W	CS011
S		U061	User pump overload protector: input logic 0/1=NO/NC	0	0	1	-	R/W	CS012
S		U062	2nd set point: input logic - 0/1=NO/NC	1	0	1	-	R/W	CS013
M		U063	User pump: output logic - 0/1=NO/NC	0	0	1	-	R/W	CS014
S		U064	Global alarm relay: output logic - 0/1=NO/NC	0	0	1	-	R/W	CS015
S		U065	Free cooling valve: output logic - 0/1=NO/NC	0	0	1	-	R/W	CS016
M		U066	Frost protection heater: output logic - 0/1=NO/NC	0	0	1	-	R/W	CS017
S		U067	Alarm relay configuration - 0/1=Control alarms/All	0	0	1	-	R/W	CS018
S		U068	Free cooling: enable - 0/1=no/yes	0	0	1	-	R/W	CS019
S		U069	Free cooling: activation differential	3.0	0.0	99.9	K/R	R/W	HR085 (2R)
S		U070	Free cooling: hysteresis	1.5	0.0	99.9	K/R	R/W	HR087 (2R)
S		U071	Design free cooling delta T	8.0	0.0	99.9	K/R	R/W	HR089 (2R)
S		U072	Water free cooling: valve closing threshold	5.0	-999.9	999.9	°C/°F	R/W	HR091 (2R)
S		U073	Water free cooling: valve closing differential	3.0	0.0	99.9	K/R	R/W	HR093 (2R)
M		U074	Free cooling type 0=Air - 1=Remote coil - 2=Water	0	0	2	-	R/W	HR095
S		U075	Frost protection type 0=Heater - 1=Pump - 2=Heater/Pump	2	0	2	-	R/W	HR096
M		U076	Number of user pumps	1	1	2	-	R/W	HR097
M		U077	Type of unit 0= CH; 1= HP; 2= CH/HP 3= Condensing unit CH 4= Condensing unit CH/HP	0	0	4	-	R/W	HR098
S		U078	Unit pump in standby: enable On-Off cycles 0/1=No/Yes	0	0	1	-	R/W	CS080
S		U079	Unit pump in standby: On time	3	1	15	min	R/W	HR709
S		U080	Unit pump in standby: Off time	15	3	99	min	R/W	HR710
S		U081	Pressure alarm reset configuration	7	0	7	-	R/W	HR239
M		U082	Frost protection type 0 = Evaporation temperature 1 = Water delivery temperature	0	0	1	-	R/W	CS093

6.2 Compressor

User	Displ.	Code	Description	Def.	Min	Max	UOM	R/W	Modbus
CMP=Compressor									
S		C000	Comp. 1 circuit 1: maintenance hour threshold(x100)	99	0	999	h	R/W	HR153
S		C001	Comp. 1 circuit 1: reset hour counter	0	0	1	-	R/W	CS023
S	x	C002	Comp. 1 circuit 1: operating mode 0=AUTO - 1=OFF - 2=ON	0	0	2	-	R/W	HR154
S		C003	Comp. 2 circuit 1: maintenance hour threshold(x100)	99	0	999	h	R/W	HR155
S		C004	Comp. 2 circuit 1: reset hour counter	0	0	1	-	R/W	CS024
S	x	C005	Comp. 1 circuit 2: operating mode 0=AUTO - 1=OFF - 2=ON	0	0	2	-	R/W	HR156
S		C006	Comp. 1 circuit 2: maintenance hour threshold(x100)	99	0	999	h	R/W	HR157
S		C007	Comp. 2 circuit 1: reset hour counter	0	0	1	-	R/W	CS025
S	x	C008	Comp. 2 circuit 1: operating mode 0=AUTO - 1=OFF - 2=ON	0	0	2	-	R/W	HR158
S		C009	Comp. 2 circuit 2: maintenance hour threshold(x100)	99	0	999	h	R/W	HR159
S		C010	Comp. 2 circuit 2: reset hour counter	0	0	1	-	R/W	CS026
S	x	C011	Comp. 2 circuit 2: operating mode 0=AUTO - 1=OFF - 2=ON	0	0	2	-	R/W	HR160
M		C012	Min compressor on time	180	30	999	s	R/W	HR162
M		C013	Min compressor off time	60	30	999	s	R/W	HR163
M		C014	Min time between consecutive compressor starts	360	300	999	s	R/W	HR164
M		C017	Max high pressure threshold (HP)	65.0	0.0	999.9	°C/°F	R/W	HR324 (2R)
M		C018	Min low pressure threshold (LP)	0.2	-99.9	99.9	bar	R/W	HR326 (2R)
M		C020	Maximum circuit destabilisation time	240	5	999	min	R/W	HR168
S		C022	Circuit 1: discharge temp. offset	0.0	-99.9	99.9	K/R	R/W	HR170 (2R)
S		C023	Circuit 1: suction temp. offset	0.0	-99.9	99.9	K/R	R/W	HR172 (2R)
S		C024	Circuit 2: discharge temp. offset	0.0	-99.9	99.9	K/R	R/W	HR174 (2R)
S		C025	Circuit 2: suction temp. offset	0.0	-99.9	99.9	K/R	R/W	HR176 (2R)

User	Disp	Code	Description	Def.	Min	Max	UOM	R/W	Modbus
S		C026	Circuit 1: condensation pressure offset	0.0	-99.9	99.9	bar	R/W	HR178 (2R)
S		C027	Circuit 1: evaporation pressure offset	0.0	-99.9	99.9	bar	R/W	HR180 (2R)
S		C028	Circuit 1: condensing temp. offset	0.0	-99.9	99.9	K/R	R/W	HR182 (2R)
S		C029	Circuit 1: evaporation temp. offset	0.0	-99.9	99.9	K/R	R/W	HR184 (2R)
S		C030	Circuit 2: condensation pressure offset	0.0	-99.9	99.9	bar	R/W	HR186 (2R)
S		C031	Circuit 2: evaporation pressure offset	0.0	-99.9	99.9	bar	R/W	HR188 (2R)
S		C032	Circuit 2: condensing temp. offset	0.0	-99.9	99.9	K/R	R/W	HR190 (2R)
S		C033	Circuit 2: evaporation temp. offset	0.0	-99.9	99.9	K/R	R/W	HR192 (2R)
M		C034	HP pressure switch: input logic - 0/1=NC/NO	0	0	1	-	R/W	CS027
M		C035	Compressor overload protector: input logic 0/1=NC/NO	0	0	1	-	R/W	CS028
M		C036	Compressor: output logic - 0/1=NO/NC	0	0	1	-	R/W	CS029
M		C037	Evaporation pressure: probe type - 0=0-5V - 1=4-20mA	0	0	1	-	R/W	HR194
M		C038	Evaporation pressure probe: min value	0.0	-1.0	99.9	bar	R/W	HR195 (2R)
M		C039	Evaporation pressure probe: max value	17.3	0.0	99.9	bar	R/W	HR197 (2R)
M		C040	Condensation pressure: probe type - 0=0-5V 1=4- 20mA	0	0	1	-	R/W	HR199
M		C041	Condensation pressure probe: min value	0.0	-1.0	99.9	bar	R/W	HR200 (2R)
M		C042	Condensation pressure probe: max value	45.0	0.0	99.9	bar	R/W	HR202 (2R)
M		C044	Enable destabilisation - 0/1=No/Yes	1	0	1	-	R/W	CS030
S		C045	Refrigerant 3=R407C - 4=R410a - 6=R290 - 10=R744 - 22=R32	4	0	99	-	R	IR038
M		C046	No. of unit circuits	1	1	2	-	R/W	HR206
M		C047	Type of compressors used 0=1 On/Off - 1=2 On/Off - 2=1 BLDC - 3= 1 BLDC+On/Off	0	0	3	-	R/W	HR207
M		C049	LP pressure switch: alarm delay from compressor start	90	0	999	-	R/W	HR269
M		C050	LP pressure switch: alarm delay in steady operation	15	0	999	-	R/W	HR269
M		C051	HP pressure switch: input logic 0=NC 1=NO	0	0	1	-	R/W	CS76

6.2.1 Inverter compressor

User	Dis	Code	Description	Def	Min	Max	UOM	R/W	Modbus
S		P000	Min evaporation temp.: custom limit	-	-	999.9	°C/°F	R/W	HR335 (2R)
S		P001	Max condensing temp.: custom limit	25.0	99.9	-	°C/°F	R/W	HR337 (2R)
M		P003	Out of envelope alarm delay	120	0	999	s	R/W	HR340
M		P004	Low pressure differential alarm delay	60	0	999	s	R/W	HR341
M		P006	Oil recovery: min request for activation	35.0	0.0	100.0	%	R/W	HR344 (2R)
M		P007	Oil recovery: min speed for activation	35.0	0.0	999.9	rps	R/W	HR346 (2R)
M		P008	Oil recovery: comp. operating time at low speed	15	0	999	min	R/W	HR348
M		P009	Oil recovery: force comp. speed time	3	0	999	min	R/W	HR349
M		P010	Oil recovery: force comp. speed value	50.0	0.0	999.9	rps	R/W	HR350 (2R)
M		P011	Oil equalisation: solenoid valve opening time at start-up	30	0	999	s	R/W	HR352
M		P012	Oil equalisation: solenoid valve opening time	3	0	999	s	R/W	HR353
M		P013	Oil equalisation: min solenoid valve closed time	1	0	999	min	R/W	HR354
M		P014	Oil equalisation: max solenoid valve closed time	15	0	999	min	R/W	HR355
M		P015	Oil equalisation: solenoid valve closed time increment	20	0	999	min	R/W	HR356
S		P016	Oil equalisation valve: output logic - 0/1=NO/NC	0	0	1	-	R/W	CS66
M		P017	Enable oil equalisation valve - 0/1=No/Yes	0	0	1	-	R/W	CS67
M		P018	Enable oil recovery - 0/1=No/Yes	0	0	1	-	R/W	CS68
S	x	P019	BLDC compressor circ.1: operating mode 0=AUTO; 1=0%, ...101=100%	0	010	1-	R/W	HR357	
S	x	P020	BLDC compressor circ.2: operating mode 0=AUTO; 1=0%, ...101=100%	0	0	101	-	R/W	HR358
M		P021	Max. deltaP at start-up	900.0	0.0	2000.0	kPa	R/W	HR359 (2R)
M		P022	EVD: max pre-opening time for pressure equalisation	10	0	999	s	R/W	HR361
M		P023	EVD: pre-opening value for pressure equalisation	50.0	0.0	100.0	%	R/W	HR362 (2R)
M		P024	Start-up speed	50.0	20.0	120.0	rps	R/W	HR363 (2R)
M		P025	Custom speed: max value	120.0	0.0	999.9	rps	R/W	HR365 (2R)
M		P026	Custom speed: min value	0	20.0	0.0	999.9	rps	HR367 (2R)
S		P030	Skip frequency: centre point [010]	0.0	0.0	999.9	Hz	R/W	HR375 (2R)
S		P031	Skip frequency: band [011]	0.0	0.0	999.9	Hz	R/W	HR377 (2R)
M		P032	Enable motor over-temperature alarm (PTC) [027] - 0/1=No/Yes	0	0	1	-	R/W	HR379
M		P033	Motor over-temperature delay delay (PTC) [028]	0	0	999	s	R/W	HR380
M		P034	Enable crankcase heater function - 0/1=No/Yes	0	0	1	-	R/W	CS69



6.3 Electronic valve

User	Disp.	Code	Description	Def.	Min	Max	UOM	R/W	Modbus
EEU =Valve									
S		E000	ExV circuit 1: manual mode - 0/1=No/Yes	0	0	1	-	R/W	CS020
S		E001	ExV circuit 1: steps in manual mode	0	0	65535	steps	R/W	HR099
S		E002	ExV circuit 2: manual mode - 0/1=No/Yes	0	0	1	-	R/W	CS021
S		E003	ExV circuit 2: steps in manual mode	0	0	65535	steps	R/W	HR100
S	x	E004	SH in cooling: set point	6.0	-40.0	180.0	K/R	R/W	HR101 (2R)
S		E005	SH in cooling: Kp	15.0	0.0	800.0	-	R/W	HR103 (2R)
S		E006	SH in cooling: Ti	150	0.0	1000.0	s	R/W	HR105 (2R)
S		E007	SH in cooling: Td	1.0	0.0	800.0	s	R/W	HR107 (2R)
S	x	E008	SH in heating: set point	6.0	-40.0	180.0	K/R	R/W	HR109 (2R)
S		E009	SH in heating: Kp	15.0	0.0	800.0	-	R/W	HR111 (2R)
S		E010	SH in heating: Ti	150	0.0	1000.0	s	R/W	HR113 (2R)
S		E011	SH in heating: Td	1.0	0.0	800.0	s	R/W	HR115 (2R)
S		E012	LowSH in cooling: threshold	1.0	-40.0	180.0	K/R	R/W	HR117 (2R)
S		E013	LowSH in cooling: Ti	10.0	0.0	800.0	s	R/W	HR119 (2R)
S		E014	LowSH in heating: threshold	1.0	-40.0	180.0	K/R	R/W	HR121 (2R)
S		E015	LowSH in heating: Ti	10.0	0.0	800.0	s	R/W	HR123 (2R)
S		E016	LOP in cooling: threshold	-5.0	-60.0	200.0	°C/°F	R/W	HR125 (2R)
S		E017	LOP in cooling: Ti	5.0	0.0	800.0	s	R/W	HR127 (2R)
S		E018	LOP in heating: threshold	-50.0	-60.0	200.0	°C/°F	R/W	HR129 (2R)
S		E019	LOP in heating: Ti	5.0	0.0	800.0	s	R/W	HR131 (2R)
M		E020	MOP in cooling: threshold	30.0	-60.0	200.0	°C/°F	R/W	HR133 (2R)
M		E021	MOP in cooling: Ti	15.0	0.0	800.0	s	R/W	HR135 (2R)
M		E022	MOP in heating: threshold	20.0	-60.0	200.0	°C	R/W	HR137 (2R)
M		E023	MOP in heating: Ti	15.0	0.0	800.0	s	R/W	HR139 (2R)
M		E024	LowSH: alarm delay time	300	0	18000	s	R/W	HR141
M		E025	LOP: alarm delay time	300	0	18000	s	R/W	HR142
M		E026	MOP: alarm delay time	300	0	18000	s	R/W	HR143
M		E032	Valve opening % at start-up (EVAP/EEV capacity ratio) in cooling	100	0	100	%	R/W	HR144
M		E033	Valve opening % at start-up (EVAP/EEV capacity ratio) in heating	100	0	100	%	R/W	HR145
M		E034	Control delay after pre-positioning	6	3	18000	s	R/W	HR146
M		E046	EVD Evolution: valve (1=CAREL EXV, ...) (*)	1	1	35	-	R/W	HR048
S		E047	ExV driver (0=Disabled, 1=Built-in, 2=EVD Evolution)	0	0	2	-	R/W	HR328

6.4 Source

User	Display	Code	Description	Def.	Min	Max	UOM	R/W	Modbus
Src = Source									
S		S000	Source pump 1: maintenance hour threshold (x100)	99	0	999	h	R/W	HR209
S		S001	Source pump 1: reset hour counter	0	0	1	-	R/W	CS031
S	x	S002	Source pump 1: operating mode 0=AUTO - 1=OFF - 2=ON	0	0	2	-	R/W	HR210
S		S008	Source fan 1 circuit 1: maintenance hour threshold (X100)	99	0	999	h	R/W	HR214
S		S009	Source fan 1 circuit 1: reset hour counter	0	0	1	-	R/W	CS033
S	x	S010	Source ON/OFF fan 1 circuit 1: operating mode -0=AUTO - 1=OFF - 2=ON	0	0	2	-	R/W	HR215
S	x	S011	Source modulating fan circuit 1: operating mode -0=AUTO - 1=0% - 2=1%, ..101=100%	0	0	101	-	R/W	HR216
S		S012	Source fan 1 circuit 2: maintenance hour threshold (X100)	99	0	999	h	R/W	HR217
S		S013	Source fan 1 circuit 2: reset hour counter	0	0	1	-	R/W	CS034
S	x	S014	Source ON/OFF fan circuit 2: operating mode 0=AUTO - 1=OFF - 2=ON	0	0	2	-	R/W	HR218
S	x	S015	Source modulating fan circuit 2: operating mode 0=AUTO - 1=0% - 2=1%, ..101=100%	0	0	101	-	R/W	HR219
S		S016	Source fan: cold climate temperature threshold	-0.5	-999.9	999.9	°C/°F	R/W	HR220 (2R)
S		S017	Source fan: min cold climate speed	10.0	0.0	100.0	%	R/W	HR222 (2R)
S		S018	Source fan: cold climate speed at start-up	50.0	0.0	100.0	%	R/W	HR224 (2R)
S		S019	Source fan: cold climate speed at start-up time	5	0	300	s	R/W	HR226
S	x	S020	Enable noise reduction - 0/1=No/Yes	0	0	1	-	R/W	CS035
S		S021	Noise reduction time band: start hours	22	0	23	h	R/W	HR167
S		S022	Noise reduction time band: start minutes	30	0	59	min	R/W	HR212
S		S023	Noise reduction time band: end hours	8	0	23	h	R/W	HR041
S		S024	Noise reduction time band: end minutes	30	0	59	min	R/W	HR042
S		S025	Source fan: noise reduction set point	45.0	0.0	999.9	°C/°F	R/W	HR231 (2R)
S		S026	Compressor start delay after pump start	30	0	999	s	R/W	HR233

User	Displ.	Code	Description	Def.	Min	Max	UOM	R/W	Modbus
S		S027	Pump shutdown delay after compressor off	10	0	999	s	R/W	HR234
S		S028	Source fan in cooling: set point	30.0	-999.9	999.9	°C/°F	R/W	HR235 (2R)
S		S029	Source fan in heating: set point	10.0	0.0	99.9	°C/°F	R/W	HR237 (2R)
S		S031	Source fan in cooling: set point at start-up	45.0	0.0	999.9	°C/°F	R/W	HR241 (2R)
S		S032	Source fan: delay at start-up in cooling	240	0	999	s	R/W	HR243
S		S034	Source fan: differential in cooling	15.0	0.0	99.9	K	R/W	HR246 (2R)
S		S035	Source fan: differential in heating	5.0	0.0	99.9	K	R/W	HR248 (2R)
S		S036	Modulating source fan: min speed value	20.0	0.0	100.0	%	R/W	HR250 (2R)
S		S037	Modulating source fan: max speed value	80.0	0.0	100.0	%	R/W	HR252 (2R)
S		S039	Defrost: start temperature	-1.0	-99.9	99.0	°C/°F	R/W	HR254 (2R)
S		S040	Defrost: reset start defrost delay threshold	1.0	S039	99.9	°C/°F	R/W	HR256 (2R)
S		S041	Defrost: delay at start-up	30	0	999	min	R/W	HR258
S		S042	Defrost: end temperature	52.0	-999.9	999.9	°C/°F	R/W	HR259 (2R)
S		S043	Enable sliding defrost - 0/1=No/Yes	0	0	1	-	R/W	CS037
S		S044	Operation time at min capacity before cycle reversing	20	0	999	s	R/W	HR261
S		S045	Operation time at min capacity after cycle reversing	30	0	999	s	R/W	HR262
S		S046	Defrost: min duration	1	0	99	min	R/W	HR263
S		S047	Defrost: max duration	5	0	99	min	R/W	HR264
S		S048	Dripping: duration - 0=Dripping not performed	90	0	999	s	R/W	HR265
S		S049	Post-dripping: duration - 0=Post-dripping not performed	30	0	999	s	R/W	HR266
S		S050	Minimum delay between consecutive defrosts	20	0	999	min	R/W	HR267
S		S051	BLDC compressor speed in defrost	80.0	0.0	999.9	rps	R/W	HR382 (2R)
S		S052	BLDC compressor speed for cycle reversing in defrost	40.0	0.0	999.9	rps	R/W	HR384 (2R)
S		S053	Defrost synchronisation - 0=Independent - 1=Separate - 2=Simultaneous	0	0	2	-	R/W	HR272
M		S054	4-way valve: pressure differential for reversing	3.0	0.0	999.9	bar	R/W	HR274 (2R)
M		S055	Compressor after defrost - 0/1=On/Off	0	0	1	-	R/W	CS038
S		S056	BLDC smart start: duration (*)	20	0	999	s	R/W	HR278
S		S057	Source frost protection: alarm threshold	-0.8	-999.9	999.9	K/R	R/W	HR279 (2R)
S		S058	Source frost protection: alarm differential	30.0	0.0	999.9	K/R	R/W	HR281 (2R)
S		S059	Frost protection alarm delay at threshold -1K	30	0	999	s	R/W	HR283
S		S060	Source: outside air temperature probe offset	0.0	-99.9	99.9	K/R	R/W	HR284 (2R)
M		S061	Source fan: output logic - 0/1=NO/NC	0	0	1	-	R/W	CS039
M		S062	Source pump: output logic - 0/1=NO/NC	0	0	1	-	R/W	CS040
S		S063	Reversing valve: output logic - 0/1=NO/NC	0	0	1	-	R/W	CS041
S		S064	Type of source air circuit 0=Independent - 1=Common	0	0	1	-	R/W	CS042
S		S065	Type of source fan - 0/1=Modulating/ON-OFF	0	0	1	-	R/W	CS044
S		S068	Unit type - 0=Air - 1=Water	0	0	1	-	R/W	CS046
S		S069	Defrost with fans: outside temperature threshold 0.0°C/32.0°F=Function disabled	0.0	0.0	99.9	-	R/W	HR736
S		S072	Source pump activation 0=on with unit on 1=on with compressor on 2=modulating on/off with condensing temperature	0	0	2	-	R/W	HR213
S		S073	Compressor status at start defrost 0=On minimum speed - 1=Off	0	0	1	-	R/W	CS92

6.5 Input /output configuration

User	Displ.	Code	Description	De f.	Mi n	Max	UOM	R/W	Modbus
S		Hc31	S1 configuration	7	0	8	-	R/W	HR752
S		Hc32	S2 configuration	8	0	8	-	R/W	HR753
S		Hc00	S3 configuration	0	0	8	-	R/W	HR286
		S008	Source fan 1 circuit 1 maintenance hour threshold (x100)	99	0	999	h	R/W	HR214
M		Hc01	S4 and S5 configuration 0=Pressure - 1=Temperature	0	0	1	-	R/W	HR287
M		Hc02	Enable S4 0/1=No/Yes	1	0	1	-	R/W	CS048
S		Hc34	S4 configuration	7	0	10	-	R/W	HR754
S		Hc35	S5 configuration	8	0	10	-	R/W	HR755
S		Hc03	S6 configuration	0	0	11	-	R/W	HR288
S		Hc04	S7 configuration (DIN)	6	0	8	-	R/W	HR289
S		Hc41	S1 configuration (Circuit 2)	0	0	8	-	R/W	HR756
S		Hc42	S2 configuration (Circuit 2)	0	0	8	-	R/W	HR757
S		Hc43	S3 configuration (Circuit 2)	0	0	8	-	R/W	HR758
S		Hc44	S4 configuration (Circuit 2)	7	0	10	-	R/W	HR759
S		Hc45	S5 configuration (Circuit 2)	8	0	10	-	R/W	HR760
S		Hc05	S6 configuration (Circuit 2)	0	0	11	-	R/W	HR290
S		Hc47	S7 configuration (Circuit 2)	6	0	8	-	R/W	HR761
S		Hc14	ID1 configuration	1	0	10	-	R/W	HR297

User	Disp.	Code	Description	Def.	Min	Max	UOM	R/W	Modbus
S		Hc15	ID2 configuration	2	0	10	-	R/W	HR298
S		Hc06	ID4 configuration	0	0	10	-	R/W	HR291
S		Hc07	ID5 configuration	7	0	10	-	R/W	HR292
S		Hc08	ID6 configuration	6	0	10	-	R/W	HR293
S		Hc16	ID1 configuration (Circuit 2)	10	0	10	-	R/W	HR299
S		Hc17	ID2 configuration (Circuit 2)	2	0	10	-	R/W	HR300
S		Hc09	ID4 configuration (Circuit 2)	0	0	10	-	R/W	HR294
S		Hc10	ID5 configuration (Circuit 2)	7	0	10	-	R/W	HR295
S		Hc11	ID6 configuration (Circuit 2)	0	0	10	-	R/W	HR296
S		Hc51	NO1 configuration	1	0	11	-	R/W	HR740
S		Hc52	NO2 configuration	2	0	11	-	R/W	HR741
S		Hc53	NO3 configuration	4	0	11	-	R/W	HR742
S		Hc54	NO4 configuration	7	0	11	-	R/W	HR743
S		Hc55	NO5 configuration	10	0	11	-	R/W	HR744
S		Hc56	NO6 configuration	0	0	11	-	R/W	HR745
S		Hc61	NO1 configuration (Circuit 2)	1	0	8	-	R/W	HR746
S		Hc62	NO2 configuration (Circuit 2)	2	0	8	-	R/W	HR747
S		Hc63	NO3 configuration (Circuit 2)	4	0	8	-	R/W	HR748
S		Hc64	NO4 configuration (Circuit 2)	7	0	8	-	R/W	HR749
S		Hc65	NO5 configuration (Circuit 2)	0	0	8	-	R/W	HR750
S		Hc66	NO6 configuration (Circuit 2)	0	0	8	-	R/W	HR751
S		Hc71	Y1 configuration	1	0	3	-	R/W	HR240
S		Hc72	Y2 configuration	3	0	3	-	R/W	HR245
S		Hc81	Y1 configuration (Circuit 2)	1	0	2	-	R/W	HR244
S		Hc82	Y2 configuration (Circuit 2)	0	0	2	-	R/W	HR276
S		Hc13	Buzzer 0/1=No/Yes	0	0	1	-	R/W	CS050

Notes: (1) Max = 3 with Panel model, Max = 2 with DIN model.

6.6 mCH2 Parameters (Legacy model only)

User	Disp.	Code	Description	Def.	Min	Max	UOM	R/W	Modbus
M	x	F027	Capacity stepped compressors (0= NO, 1= YES)	0	0	1	-	-	-
M	x	F003	Number of evaporators (0=1; 1=YES)	0	0	1	-	-	-
M	x	F007	S4 sensor installed on source exchanger (0= No, 1=Yes: in CH read condensation, in HP read evaporation)	0	0	1	-	-	-
M	x	F008	Antifreeze alarm delay	10	0.0	999	-	-	-
M	x	F009	Supply air temperature limit threshold	14.0	0.0	99.9	°C	-	-
M	x	F010	Supply air differential limit temperature	4.0	0.0	20.0	°K	-	-
M	x	F011	Resistance digital output logic (0=N.O.; 1=N.C.)	0	0	1	°K	-	-
M	x	F012	Setpoint offset in summer operating mode for heaters	1.0	0.0	99.9	°K	-	-
M	x	F013	Differential for summer setpoint operating mode for heat resistance	0.5	0.2	99.9	°K	-	-
M	x	F014	Offset on setpoint in winter operating mode for heaters	3.0	0.0	99.9	°K	-	-
M	x	F015	Differential on set point in winter operating mode for heaters	1.0	0.2	99.9	°K	-	-
M	x	F016	Active resistance during defrost v (0= No, 1=Yes)	0	0	1	-	-	-
M	x	F017	Supply fan operating mode (0=Always ON; 1=ON by thermoregulation)	0	0	1	-	-	-
M	x	F018	Hot start setpoint	40.0	0.0	99.9	°C	-	-
M	x	F019	Hot-keep differential	5.0	0.0	99.9	°K	-	-
M	x	F020	Compressor request logic from digital input (0=N.C.; 1=N.O.)	1	0	1	-	-	-
M	x	F021	Mix outlet water temperature probe calibration (S1 expansion)	0.0	-99.9	99.9	°K	-	-
M	x	F022	Evaporator 2 water outlet temperature probe calibration (S2 expansion)	0.0	-99.9	99.9	°K	-	-
M	x	F023	Direct relationship between digital inputs and digital outputs for condensing unit (0=No; 1=Yes)	0	0	1	-	-	-



6.7 BMS port

User	Disp.	Code	Description	Def.	Min	Max	UOM	R/W	Modbus
S	x	Hd00	BMS: serial address	1	1	247	-	-	HR147
S	x	Hd01	BMS: baud rate 3=9600; 4=19200; 5=38400; 6=57600; 7=115200	7	3	7	-	-	HR148
S	x	Hd02	BMS: settings 0= 8-NONE-1 - 1= 8-NONE-2 - 2= 8-EVEN-1 3= 8-EVEN-2 - 4= 8-ODD-1 - 5= 8-ODD-2	1	0	5	-	-	HR149
S	x	Hd07	BMS: supervisor database 0= 32bit 1= 16bit	0	0	1	-	-	CS48

6.8 Password

User	Disp.	Code	Description	Def.	Min	Max	UOM	R/W	Modbus
U		He00	User password	1000	0000	9999	-	-	-
S		He01	Service password	2000	0000	9999	-	-	-
M		He02	Manufacturer password	1234	0000	9999	-	-	-
M		He03	Password for profile 1	0001	0000	9999	-	-	-
M		He04	Password for profile 2	0002	0000	9999	-	-	-
M		He05	Password for profile 3	0003	0000	9999	-	-	-
M		He06	Password for profile 4	0004	0000	9999	-	-	-
M		He07	Password for profile 5	0005	0000	9999	-	-	-
M		He08	Password for profile 6	0006	0000	9999	-	-	-
M		He09	Password for profile 7	0007	0000	9999	-	-	-



6.9 Dashboard values

User	Disp.	Code	Description	Def.	Min	Max	UOM	R/W	Modbus
U	x	AFC1	Circuit 1: source water delivery temperature	-	-999.9	999.9	°C/°F	R	IR217 (2R)
U	x	AFC2	Circuit 2: source water delivery temperature	-	-999.9	999.9	°C/°F	R	IR213 (2R)
U	x	EuP1	Circuit 1: evaporation temperature (or converted value)	-	-999.9	999.9	°C/°F	R	IR026 (2R)
U	x	EuP2	Circuit 2: evaporation temperature (or converted value)	-	-999.9	999.9	°C/°F	R	IR034 (2R)
U		dSP1	Circuit 1: condensation pressure	-	-999.9	999.9	bar/psi	R	IR020 (2R)
U		dSP2	Circuit 2: condensation pressure	-	-999.9	999.9	bar/psi	R	IR028 (2R)
U	x	dSt1	Circuit 1: discharge temperature	-	-999.9	999.9	°C/°F	R	IR012 (2R)
U	x	dSt2	Circuit 2: discharge temperature	-	-999.9	999.9	°C/°F	R	IR016 (2R)
U	x	rUSr	User: return water temperature	-	-999.9	999.9	°C/°F	R	IR054 (2R)
U	x	dUSr	User: delivery water temperature	-	-999.9	999.9	°C/°F	R	IR056 (2R)
U	x	Cnd1	Circuit 1: condensing temperature (or converted value)	-	-999.9	999.9	°C/°F	R	IR024 (2R)
U	x	Cnd2	Circuit 2: condensing temperature (or converted value)	-	-999.9	999.9	°C/°F	R	IR032 (2R)
U		Sprb	Source: outside air temperature	-	-999.9	999.9	°C/°F	R	HR229
U		ScP1	Circuit 1: suction pressure	-	-999.9	999.9	bar/psi	R	IR022 (2R)
U		ScP2	Circuit 2: suction pressure	-	-999.9	999.9	bar/psi	R	IR030 (2R)
U		Sct1	Circuit 1: suction temperature	-	-999.9	999.9	°C/°F	R	IR014 (2R)
U		Sct2	Circuit 2: suction temperature	-	-999.9	999.9	°C/°F	R	IR018 (2R)
U	x	SetA	Current set point	-	-999.9	999.9	°C/°F	R	IR046 (2R)
U		rSPt	Remote set point	-	-999.9	999.9	°C/°F	R	IR090 (2R)
U		Opn1	ExV circuit 1: position	-	0	9999	%	R	IR050
U		Opn2	ExV circuit 2: position	-	0	9999	%	R	IR053
U	x	SSH1	Circuit 1: suction superheat	-	-999.9	999.9	°C/°F	R	IR048 (2R)
U	x	SSH2	Circuit 2: suction superheat	-	-999.9	999.9	°C/°F	R	IR051 (2R)
S	x	Hd00	BMS: serial address	1	1	245	-	R	HR147
S	x	Hd01	BMS: baud rate	7	3	7	-	R	HR148
S	x	Hd02	BMS: settings 0=8-NONE-1 2=8-EVEN-1 4=8-ODD-1 1=8-NONE-2 3=8-EVEN-2 5=8-ODD-2	0	0	5	-	R	HR149
S		H1C1	Comp. 1 circuit 1: hour counter	-	0	99999	h	R	IR004 (2R)
S		H1C2	Comp. 2 circuit 1: hour counter	-	0	99999	h	R	IR006 (2R)
S		H2C1	Comp. 2 circuit 1: hour counter	-	0	99999	h	R	IR008 (2R)
S		H2C2	Comp. 2 circuit 2: hour counter	-	0	99999	h	R	IR010 (2R)
S		HSP1	Source pump: hour counter	-	0	99999	h	R	IR036 (2R)
S		HuP1	User pump 1: hour counter	-	0	99999	h	R	IR000 (2R)
S		HuP2	User pump 2: hour counter	-	0	99999	h	R	IR002 (2R)
S		HFn1	Fan circuit 1: hour counter	-	0	99999	h	R	IR040 (2R)
S		HFn2	Fan circuit 2: hour counter	-	0	99999	h	R	IR042 (2R)
S	x	rps1	BLDC 1 speed	-	0	999.9	rps	R	IR100 (2R)
S	x	rps2	BLDC 2 speed	-	0	999.9	rps	R	IR181 (2R)
S	x	Mc1	BLDC 1 current	-	0	99.9	A	R	IR102 (2R)
S	x	Mc2	BLDC 2 current	-	0	99.9	A	R	IR183 (2R)
S		MP1	BLDC 1 power	-	0	99.9	kW	R	IR104 (2R)
S		MP2	BLDC 2 power	-	0	99.9	kW	R	IR185 (2R)
S		Drt1	Current speed drive 1 temperature	-	0	999.9	°C/°F	R	IR106 (2R)
S		Drt2	Current speed drive 2 temperature	-	0	999.9	°C/°F	R	IR187 (2R)
S		AIHs1_1	Speed drive 1 alarm log: last	-	0	99		R	IR108
S		AIHs2_1	Speed drive 1 alarm log: second-to-last	-	0	99		R	IR109
S		AIHs3_1	Speed drive 1 alarm log: third-to-last	-	0	99		R	IR110
S		AIHs4_1	Speed drive 1 alarm log: fourth-to-last	-	0	99		R	IR111
S		AIHs1_2	Speed drive 2 alarm log: last	-	0	99		R	IR189
S		AIHs2_2	Speed drive 2 alarm log: second-to-last	-	0	99		R	IR190
S		AIHs3_2	Speed drive 2 alarm log: third-to-last	-	0	99		R	IR191
S		AIHs4_2	Speed drive 2 alarm log: fourth-to-last	-	0	99		R	IR192



6.10 Settings

User	Display	Code	Description	Def.	Min	Max	UOM	R/W	Modbus
U	x	SEtC	Cooling set point	7.0	U006	U007	°C/°F	R/W	HR307 (2R)
U	x	SEtH	Heating set point	40.0	U008	U009	°C/°F	R/W	HR309 (2R)
U	x	0-1	Unit On-Off from keypad 0=OFF 1=ON	0	0	1	-	R/W	CS54
U	x	ModE	Cooling/heating from keypad 0=Cooling 1=Heating	0	0	1	-	R/W	CS55
-		RES	Reset alarms from BMS 0/1=No/Yes	0	0	1	-	R/W	CS56
S	x	DFr	Force defrost 0=No 1=Circuit 1 2=Circuit 2 3=Circuit 1 and 2	0	0	3	-	R/W	HR78
S	x	ClrH	Reset alarm log 0/1=No/Yes	0	0	1	-	R/W	CS59
S	x	UoM	Unit of measure 0=°C/barg 1=°F/psig	0	0	1	-	R/W	CS47
S	x	rStr	Reset factory parameters	0	0	1	-	R/W	CS45

7. Supervisor table

µChiller provides a database of supervisor variables via Modbus RTU protocol over RS485 (BMS port on the µChiller controller). The BMS port has the following default settings:

- baud rate 115,200;
- data bits 8;
- no parity;
- stop bits 1.

See "Parameter table: BMS port" to set different values.

"Index" is the address specified in the Modbus® frame.

7.1 Coil Status

Index	Size	Ref.	Type	Min/Max	R/W	UoM	Description
0	1	U001	BOOL		R/W		U001 - User pump 1 reset hour counters
1	1	U004	BOOL		R/W		U004 - User pump 2 reset hour counters
2	1	U010	BOOL		R/W		U010 - Enable setpoint compensation (0=Disabled, 1=Enabled)
3	1	U017	BOOL		R/W		U017 - Enable scheduler (0=Disabled, 1=Enabled)
4	1	U022	BOOL		R/W		U022 - Type of scheduling (0=Switch OFF, 1=Change setpoint)
5	1	U034	BOOL		R/W		U034 - Changeover type cold/heat (0=Keyboard, 1=DIn)
6	1	U036	BOOL		R/W		U036 - Startup regulation probe (0=Return, 1=Delivery)
7	1	U038	BOOL		R/W		U038 - Run regulation probe (0=Return, 1=Delivery)
8	1	U057	BOOL		R/W		U057 - Remote alarm input logic (0=N.C., 1=N.O.)
9	1	U058	BOOL		R/W		U058 - Cool/Heat input logic (0=N.O., 1=N.C.)
10	1	U059	BOOL		R/W		U059 - Remote unit ON/OFF input logic (0=N.O., 1=N.C.)
11	1	U060	BOOL		R/W		U060 - User pump flow input logic (0=N.C., 1=N.O.)
12	1	U061	BOOL		R/W		U061 - User pump overload input logic (0=N.C., 1=N.O.)
13	1	U062	BOOL		R/W		U062 - 2nd setpoint input logic (0=N.O., 1=N.C.)
14	1	U063	BOOL		R/W		U063 - User pump output logic (0=N.O., 1=N.C.)
15	1	U064	BOOL		R/W		U064 - Global alarm relay output logic (0=N.C., 1=N.O.)
16	1	U065	BOOL		R/W		U065 - Free-Cooling valve output logic (0=N.O., 1=N.C.)
17	1	U066	BOOL		R/W		U066 - Antifreeze heater output logic (0=N.O., 1=N.C.)
18	1	U067	BOOL		R/W		U067 - Alarm relay configuration (0=Regulation alarms, 1=All alarms)
19	1	U068	BOOL		R/W		U068 - Enable Free-Cooling (0=Disabled, 1=Enabled)
20	1	E000	BOOL		R/W		E000 - ExV circ.1 enable manual mode
21	1	E002	BOOL		R/W		E002 - ExV circ.2 enable manual mode
22	1	Hd06	BOOL		R/W		Hd06 - Enable power request from BMS (0=Disabled, 1=Enabled)
23	1	C001	BOOL		R/W		C001 - Compr.1 circ.1 reset hour counters
24	1	C004	BOOL		R/W		C004 - Compr.2 circ.1 reset hour counters
25	1	C007	BOOL		R/W		C007 - Compr.1 circ.2 reset hour counters
26	1	C010	BOOL		R/W		C010 - Compr.2 circ.2 reset hour counters
27	1	C034	BOOL		R/W		C034 - High press. pressostat input logic (0=N.C., 1=N.O.)
28	1	C035	BOOL		R/W		C035 - Compr. overload input logic (0=N.C., 1=N.O.)
29	1	C036	BOOL		R/W		C036 - Compr. output logic (0=N.O., 1=N.C.)
30	1	C044	BOOL		R/W		C044 - Enable circuit destabilization (0=Disabled, 1=Enabled)
31	1	S001	BOOL		R/W		S001 - Source pump 1 reset hour counters
33	1	S009	BOOL		R/W		S009 - Source fan 1 circ.1 reset hour counters
34	1	S013	BOOL		R/W		S013 - Source fan 1 circ.2 reset hour counters
35	1	S020	BOOL		R/W		S020 - Enable low noise (0=Disabled, 1=Enabled)
37	1	S043	BOOL		R/W		S043 - Enable sliding defrost (0=Disabled, 1=Enabled)
38	1	S055	BOOL		R/W		S055 - Compr. behavior in post-defrost phase (0=Compr. is OFF, 1=Compr. is turned ON)
39	1	S061	BOOL		R/W		S061 - Source fan output logic (0=N.O., 1=N.C.)
40	1	S062	BOOL		R/W		S062 - Source pump output logic (0=N.O., 1=N.C.)
41	1	S063	BOOL		R/W		S063 - Reverse valve output logic (0=N.O., 1=N.C.)
42	1	S064	BOOL		R/W		S064 - Source flow type (0=Independent, 1=Common)
44	1	S065	BOOL		R/W		S065 - Source fan type (0=Inverter, 1=ON/OFF)
46	1	S068	BOOL		R/W		S068 - Source type (0=Air, 1=Water)
47	1	UoM	BOOL		R/W		UoM - Unit of measure used for Display 2-Row and BMS, not for Applica (0=°C/bar, 1=°F/PSI)
48	1	Hc02	BOOL		R/W		Hc02 - Analog channel 4 enabling (0=Disabled, 1=Enabled)
49	1	Hc12	BOOL		R/W		Hc12 - Digital output 6 config. (0=Antifreeze, 1=Source fan / Source pump)
50	1	Hc13	BOOL		R/W		Hc13 - Enable buzzer (0=Disabled, 1=Enabled)
52	1	Ha02	BOOL		R/W		Ha02 - Sets controller internal clock (0=No set, 1=Set)
53	1	Hd03	BOOL		R/W		Hd03 - Enable NFC (0=Disabled, 1=Enabled)
54	1	UnSt	BOOL		R/W		UnSt - Unit ON/OFF command by keyboard (0=OFF 1=ON)



Index	Size	Ref.	Type	Min/Max	R/W	UoM	Description
55	1	ModE	BOOL		R/W		ModE - Cool/Heat mode by Keyboard (0=Cool, 1=Heat)
56	1	RES	BOOL		R/W		RES - Reset active alarms by BMS net (0=NO, 1=Reset)
59	1	ClrH	BOOL		R/W		ClrH - Delete alarms log (0=No, 1=Yes)
63	1	Hd05	BOOL		R/W		Hd05 - Enable unit ON/OFF command by BMS net (0=Disabled, 1=Enabled)
64	1		BOOL		R/W		Unit ON/OFF command by BMS
66	1	P016	BOOL		R/W		P016 - Oil equalization solenoid valve circ. 1 output logic (0=NC, 1=NO)
67	1	P017	BOOL		R/W		P017 - Enable oil equalization function (0=OFF, 1=ON)
68	1	P018	BOOL		R/W		P018 - Enable oil recovery function (0=OFF, 1=ON)
69	1	P034	BOOL		R/W		P034 - Enable crandcase heater (0=OFF, 1=ON)
80	1	U078	BOOL		R/W		U078 - Burst function enabling (0=Disabled, 1=Enabled)

7.2 Input Status

Index	Size	Ref.	Type	Min/Max	R/W	UoM	Description
0	1	A01	BOOL		R		Unit - Error in the number of retain memory writings
1	1	A02	BOOL		R		Unit - Error in retain memory writings
2	1	A03	BOOL		R		Unit - Remote alarm by digital input
3	1	A04	BOOL		R		Unit - Alarm remote set point out of range
4	1	A05	BOOL		R		Unit - Alarm user return water temperature probe broken or disconnected
5	1	A06	BOOL		R		Unit - Alarm user delivery water temperature probe broken or disconnected
7	1	A08	BOOL		R		Unit - User pump 1 overload
8	1	A09	BOOL		R		Unit - User pump 2 overload
9	1	A10	BOOL		R		Unit - Flow switch alarm, no flow present with user pump 1 active
10	1	A11	BOOL		R		Unit - Flow switch alarm, no flow present with user pump 2 active
11	1	A12	BOOL		R		Unit - User pumps group alarm
12	1	A13	BOOL		R		Unit - User 1 pump maintenance
13	1	A14	BOOL		R		Unit - User 2 pump maintenance
14	1	A15	BOOL		R		Unit - High chilled water temperature
15	1	A16	BOOL		R		Unit - Alarm source return water/air temperature probe broken or disconnected
16	1	A17	BOOL		R		Unit - Source 1 pump maintenance
17	1	A18	BOOL		R		Unit - Free-cooling anomaly
18	1	A19	BOOL		R		Circuit 1 - Alarm discharge pressure probe broken or disconnected
19	1	A20	BOOL		R		Circuit 1 - Alarm condensing temperature probe broken or disconnected
20	1	A21	BOOL		R		Circuit 1 - Alarm suction pressure probe broken or disconnected
21	1	A22	BOOL		R		Circuit 1 - Alarm evaporating temperature probe broken or disconnected
22	1	A23	BOOL		R		Circuit 1 - Alarm discharge temperature probe broken or disconnected
23	1	A24	BOOL		R		Circuit 1 - Alarm suction temperature probe broken or disconnected
24	1	A25	BOOL		R		Circuit 1 - High pressure alarm by pressure switch
25	1	A26	BOOL		R		Circuit 1 - High pressure alarm by transducer
26	1	A27	BOOL		R		Circuit 1 - Low pressure alarm by transducer
27	1	A28	BOOL		R		Circuit 1 - Alarm freeze evaporation temperature
29	1	A30	BOOL		R		Circuit 1 - Overload compressor 1
30	1	A31	BOOL		R		Circuit 1 - Overload compressor 2
31	1	A32	BOOL		R		Circuit 1 - Compressor 1 maintenance
32	1	A33	BOOL		R		Circuit 1 - Compressor 2 maintenance
33	1	A34	BOOL		R		Circuit 1 - Source fan 1 maintenance
34	1	A35	BOOL		R		Circuit 1 EVD - Low superheating (SH)
35	1	A36	BOOL		R		Circuit 1 EVD - Low evaporation pressure (LOP)
36	1	A37	BOOL		R		Circuit 1 EVD - Maximum evaporating pressure (MOP)
37	1	A38	BOOL		R		Circuit 1 EVD - Valve motor error
38	1	A39	BOOL		R		Circuit 1 EVD - Emergency closing
39	1	A40	BOOL		R		Circuit 1 EVD - Incomplete valve closing
40	1	A41	BOOL		R		Circuit 1 EVD - Offline
41	1	A42	BOOL		R		Circuit 1 Envelope - General alarm + Alarm zone
42	1	A43	BOOL		R		Circuit 1 BLDC - Delta pressure greater than the allowable at startup
43	1	A44	BOOL		R		Circuit 1 BLDC - Starting failure
44	1	A45	BOOL		R		Circuit 1 BLDC - Low differential pressure
45	1	A46	BOOL		R		Circuit 1 BLDC - High discharge gas temperature
46	1	A47	BOOL		R		Circuit 1 Inverter - Offline
47	1	A48	BOOL		R		Circuit 1 Inverter - General alarm + Error code
48	1	A49	BOOL		R		Unit - Circuit 2 board is offline
49	1	A50	BOOL		R		Unit - Error in the number of retain memory writings of Circuit 2 board
50	1	A51	BOOL		R		Unit - Error in retain memory writings of Circuit 2 board
51	1	A52	BOOL		R		Circuit 2 - Alarm discharge pressure probe broken or disconnected
52	1	A53	BOOL		R		Circuit 2 - Alarm condensing temperature probe broken or disconnected
53	1	A54	BOOL		R		Circuit 2 - Alarm suction pressure probe broken or disconnected



Index	Size	Ref.	Type	Min/Max	R/W	UoM	Description
54	1	A55	BOOL		R		Circuit 2 - Alarm evaporating temperature probe broken or disconnected
55	1	A56	BOOL		R		Circuit 2 - Alarm discharge temperature probe broken or disconnected
56	1	A57	BOOL		R		Circuit 2 - Alarm suction temperature probe broken or disconnected
57	1	A58	BOOL		R		Circuit 2 - High pressure alarm by pressure switch
58	1	A59	BOOL		R		Circuit 2 - High pressure alarm by transducer
59	1	A60	BOOL		R		Circuit 2 - Low pressure alarm by transducer
60	1	A61	BOOL		R		Circuit 2 - Alarm freeze evaporation temperature
62	1	A63	BOOL		R		Circuit 2 - Overload compressor 1
63	1	A64	BOOL		R		Circuit 2 - Overload compressor 2
64	1	A65	BOOL		R		Circuit 2 - Compressor 1 maintenance
65	1	A66	BOOL		R		Circuit 2 - Compressor 2 maintenance
66	1	A67	BOOL		R		Circuit 2 - Source fan 1 maintenance
67	1	A68	BOOL		R		Circuit 2 EVD - Low superheating (SH)
68	1	A69	BOOL		R		Circuit 2 EVD - Low evaporation pressure (LOP)
69	1	A70	BOOL		R		Circuit 2 EVD - Maximum evaporating pressure (MOP)
70	1	A71	BOOL		R		Circuit 2 EVD - Valve motor error
71	1	A72	BOOL		R		Circuit 2 EVD - Emergency closing
72	1	A73	BOOL		R		Circuit 2 EVD - Incomplete valve closing
73	1	A74	BOOL		R		Circuit 2 EVD - Offline
74	1	A75	BOOL		R		Circuit 2 Envelope - General alarm + Alarm zone
75	1	A76	BOOL		R		Circuit 2 BLDC - Delta pressure greater than the allowable at startup
76	1	A77	BOOL		R		Circuit 2 BLDC - Starting failure
77	1	A78	BOOL		R		Circuit 2 BLDC - Low differential pressure
78	1	A79	BOOL		R		Circuit 2 BLDC - High discharge gas temperature
79	1	A80	BOOL		R		Circuit 2 Inverter - Offline
80	1	A81	BOOL		R		Circuit 2 Inverter - General alarm + Error code
81	1		BOOL		R		PrevAFreeze_C1 - Prevent request for antifreeze condition active inside
82	1		BOOL		R		PrevHP_C1 - Prevent request for high pressure condition active inside
83	1		BOOL		R		PrevAFreeze_C2 - Prevent request for antifreeze condition active inside
84	1		BOOL		R		PrevHP_C2 - Prevent request for high pressure condition active inside circ.2
102	1		BOOL		R		Comp1Circ1_On - Compr.1 circ.1 status (0=OFF, 1=ON)
103	1		BOOL		R		Comp2Circ1_On - Compr.2 circ.1 status (0=OFF, 1=ON)
104	1		BOOL		R		Comp1Circ2_On - Compr.1 circ.2 status (0=OFF, 1=ON)
105	1		BOOL		R		Comp2Circ2_On - Compr.2 circ.2 status (0=OFF, 1=ON)
106	1		BOOL		R		RelayAlrm - Global alarm relay
107	1		BOOL		R		CoolHeat - Unit in heating mode (0=Cooling, 1=Heating)
108	1		BOOL		R		FC_Status - Free cooling valve status (0=OFF, 1=ON)
109	1		BOOL		R		Antifreeze heater status
110	1		BOOL		R		Unit scheduler status
119	1	A87	BOOL		R		EVD - Alarm Hw incompatible
120	1		BOOL		R		SrcFanCirc1_On - Source fan circ.1 status (0=OFF, 1=ON)
121	1		BOOL		R		SrcPmp1_On - Source pump 1 status (0=OFF, 1=ON)
122	1		BOOL		R		UsrPmp1_On - User pump 1 status
123	1		BOOL		R		RevVlv_Circ1 - Reverse valve for circ.1 (0=Cooling, 1=Heating)
124	1		BOOL		R		Oil equalization valve circuit 1 status
125	1		BOOL		R		SrcFanCirc2_On - Source fan circ.2 status (0=OFF, 1=ON)
127	1		BOOL		R		UsrPmp2_On - User pump 2 status
128	1		BOOL		R		RevVlv_Circ2 - Reverse valve for circ.2 (0=Cooling, 1=Heating)
129	1		BOOL		R		Oil equalization valve circuit 2 status
131	1		BOOL		R		Defrost running on circuit 1
132	1		BOOL		R		Defrost running on circuit 2
134	1		BOOL		R		Unit status
143	1		BOOL		R		Compr.1 circuit 1 forced on by oil migration management
144	1		BOOL		R		Compr.2 circuit 1 forced on by oil migration management
145	1		BOOL		R		Compr.1 circuit 2 forced on by oil migration management
146	1		BOOL		R		Compr.2 circuit 2 forced on by oil migration management
148	1		BOOL		R		UsrFlw_Absent - User pump flow absent (0=Flow OK, 1=Flow absent)



7.3 Holding Registers

Index	Size	Ref.	Type	Min/Max	R/W	UoM	Description
2	1	U000	INT	0..999	R/W	h	U000 - User pump 1 maintenance hour threshold (x100)
3	1	U002	INT	0..2	R/W		U002 - User pump 1/fan manual mode (0=AUTO, 1=OFF, 2=ON)
4	1	U003	INT	0..999	R/W	h	U003 - User pump 2 maintenance hour threshold (x100)
5	1	U005	INT	0..2	R/W		U005 - User pump 2 manual mode (0=AUTO, 1=OFF, 2=ON)
7	2	U006	REAL	-99.9..999.9	R/W	°C/°F	U006 - Cool setpoint low limit
9	2	U007	REAL	-99.9..999.9	R/W	°C/°F	U007 - Cool setpoint high limit
11	2	U008	REAL	0..999.9	R/W	°C/°F	U008 - Heat setpoint low limit
13	2	U009	REAL	0..999.9	R/W	°C/°F	U009 - Heat setpoint high limit
15	2	U011	REAL		R/W	°C/°F	U011 - Starting temp. point for cool setpoint compensation
17	2	U012	REAL	-99.9..99.9	R/W	°C/°F	U012 - Ending temp. point for cool setpoint compensation
19	2	U013	REAL	-99.9..99.9	R/W	K/R	U013 - Max compensation for cool setpoint
21	2	U014	REAL	-999.9..999.9	R/W	°C/°F	U014 - Starting temp. point for heat setpoint compensation
23	2	U015	REAL	-99.9..99.9	R/W	°C/°F	U015 - Ext. temp. diff. point for heat setpoint compensation
25	2	U016	REAL	-99.9..99.9	R/W	K/R	U016 - Max compensation for heat setpoint
27	1	U018	INT	0..23	R/W	h	Time band hour
28	1	U019	INT	0..59	R/W	min	Time band minute
29	1	U020	INT	0..23	R/W	h	Time band hour
30	1	U021	INT	0..59	R/W	min	Time band minute
31	2	U023	REAL	U006..U007	R/W	°C/°F	U023 - 2nd cool setpoint
33	2	U024	REAL	U008..U009	R/W	°C/°F	U024 - 2nd heat setpoint
35	1	U025	INT	0..2	R/W		U025 - Analog setpoint input type (0=0-5V, 1=0-10V, 2=4-20mA)
37	2	U026	REAL	-99.9..99.9	R/W	°C/°F	U026 - Remote setpoint min value
39	2	U027	REAL	-99.9..99.9	R/W	°C/°F	U027 - Remote setpoint max value
41	1	S023	INT	0..23	R/W	h	Time band hour
42	1	S024	INT	0..59	R/W	min	Time band minute
43	2	U028	REAL	-99.9..99.9	R/W	K/R	U028 - Remote setpoint offset
48	1	E046	INT	1..24	R/W		E046 - ExV valve type for EVD EVO (1=CAREL EXV, ...)
49	2	U031	REAL	0..99.9	R/W	K/R	U031 - High water temp. setpoint offset
51	1	U032	INT	0..99	R/W	min	U032 - High water temp. startup delay
52	1	U033	INT	0..999	R/W	s	U033 - High water temp.run delay
53	1	U035	INT	0..999	R/W	min	U035 - Changeover delay time
54	1	U037	INT	0..999	R/W	s	U037 - Delay time between Startup PID and Run PID
55	2	U039	REAL	0..999.9	R/W		U039 - Startup PID Kp
57	1	U040	INT	0..999	R/W	s	U040 - Startup PID Ti
58	1	U041	INT	0..99	R/W	s	U041 - Startup PID Td
59	2	U042	REAL	0..999.9	R/W		U042 - Run PID Kp
61	1	U043	INT	0..999	R/W	s	U043 - Run PID Ti
62	1	U044	INT	0..99	R/W	s	U044 - Run PID Td
63	1	U045	INT	0..999	R/W	s	U045 - User pump flow alarm startup delay
64	1	U046	INT	0..99	R/W	s	U046 - User pump flow alarm run delay
65	1	U047	INT	0..999	R/W	s	U047 - Compr. delay ON since the user pump ON
66	1	U048	INT	0..999	R/W	s	U048 - User pump delay OFF since the compr. OFF
67	1	U049	INT	0..999	R/W	h	U049 - User pump rotation time
68	2	U050	REAL	-999.9..999.9	R/W	°C/°F	U050 - Antifreeze user alarm threshold
70	2	U051	REAL	0..999.9	R/W	K/R	U051 - Antifreeze user alarm differential
72	1	U052	INT	0..999	R/W	s	U052 - Antifreeze user alarm delay time at 1K below threshold
73	2	U053	REAL	-999.9..999.9	R/W	°C/°F	U053 - Antifreeze (with unit OFF) setpoint
75	2	U054	REAL	0..99.9	R/W	K/R	U054 - Antifreeze (with unit OFF) differential
78	1	DFr	INT	0..3	R/W		DFr - Force manual defrost (0=None, 1=Force defrost on circ. 1, 2=Forcedefrost on circ. 2, 3= Force defrost on all circuits)
79	2	U055	REAL	-99.9..99.9	R/W	K/R	U055 - Probe offset of return water temp. from user
83	2	U056	REAL	-99.9..99.9	R/W	K/R	U056 - Probe offset of delivery water temp. to user
85	2	U069	REAL	0..99.9	R/W	K/R	U069 - Delta temp. to activate Free-Cooling
87	2	U070	REAL	0..99.9	R/W	K/R	U070 - Free-Cooling ON/OFF hysteresis
89	2	U071	REAL	0..99.9	R/W	K/R	U071 - Delta temp. Free-Cooling design (to reach unit nominal capacity)
91	2	U072	REAL	-999.9..999.9	R/W	°C/°F	U072 - Free-Cooling limit threshold (used to close FC valve: because FC gives water with temp. verylow)
93	2	U073	REAL	0..99.9	R/W	K/R	U073 - Free-Cooling limit differential
95	1	U074	INT	0..2	R/W		U074 - Free-Cooling type (0=Air, 1=Remote air coil, 2=Water)
96	1	U075	INT	0..2	R/W		U075 - Antifreeze type (0=Heater, 1=Pump, 2=Heater-Pump)
97	1	U076	INT	1..2	R/W		U076 - User pump number
98	1	U077	INT	0..2	R/W		U077 - Unit type (0=CH, 1=HP, 2=CH/HP)
99	1	E001	INT	0..65535	R/W	Steps	E001 - ExV circ.1 manual mode steps
100	1	E003	INT	0..65535	R/W	Steps	E003 - ExV circ.2 manual mode steps

Index	Size	Ref.	Type	Min/Max	R/W	UoM	Description
101	2	E004	REAL	-40..180	R/W	K/R	E004 - ExV SH setpoint in cool
103	2	E005	REAL	0..800	R/W		E005 - ExV SH regulation Kp in cool
105	2	E006	REAL	0..1000	R/W	s	E006 - ExV SH regulation Ti in cool
107	2	E007	REAL	0..800	R/W	s	E007 - ExV SH regulation Td in cool
109	2	E008	REAL	-40..180	R/W	K/R	E008 - ExV SH setpoint in heat
111	2	E009	REAL	0..800	R/W		E009 - ExV SH regulation Kp in heat
113	2	E010	REAL	0..1000	R/W	s	E010 - ExV SH regulation Ti in heat
115	2	E011	REAL	0..800	R/W	s	E011 - ExV SH regulation Td in heat
117	2	E012	REAL	-40..180	R/W	K/R	E012 - ExV low SH threshold in cool
119	2	E013	REAL	0..800	R/W	s	E013 - ExV low SH Ti in cool
121	2	E014	REAL	-40..180	R/W	K/R	E014 - ExV low SH threshold in heat
123	2	E015	REAL	0..800	R/W	s	E015 - ExV low SH Ti in heat
125	2	E016	REAL	-60..200	R/W	°C/°F	E016 - ExV LOP regulation threshold in cool
127	2	E017	REAL	0..800	R/W	s	E017 - ExV LOP regulation Ti in cool
129	2	E018	REAL	-60..200	R/W	°C/°F	E018 - ExV LOP regulation threshold in heat
131	2	E019	REAL	0..800	R/W	s	E019 - EEV LOP regulation Ti in heat
133	2	E020	REAL	-60..200	R/W	°C/°F	E020 - ExV MOP regulation threshold in cool
135	2	E021	REAL	0..800	R/W	s	E021 - ExV MOP regulation Ti in cool
137	2	E022	REAL	-60..200	R/W	°C/°F	E022 - ExV MOP regulation threshold in heat
139	2	E023	REAL	0..800	R/W	s	E023 - ExV MOP regulation Ti in heat
141	1	E024	INT	0..18000	R/W	s	E024 - ExV low SH alarm delay time
142	1	E025	INT	0..18000	R/W	s	E025 - ExV LOP alarm delay time
143	1	E026	INT	0..18000	R/W	s	E026 - ExV MOP alarm delay time
144	1	E032	INT	0..100	R/W	%	E032 - ExV startup valve opening % (capacity ratio EVAP / EEV) in cool
145	1	E033	INT	0..100	R/W	%	E033 - ExV startup valve opening % (capacity ratio EVAP / EEV) in heat
146	1	E034	INT	0..18000	R/W	s	E034 - ExV regulation delay after pre-positioning
147	1	Hd00	INT	1..247	R/W		Hd00 - BMS port serial address
148	1	Hd01	INT	3..7	R/W		Hd01 - BMS port baud rate (3=9600, 4=19200, 5=38400, 6=57600, 7=115200)
149	1	Hd02	INT	0..5	R/W		Hd02 - BMS port network settings (0=8-NONE-1, 1=8-NONE-2, 2=8-EVEN-1, 3=8-EVEN-2, 4=8-ODD-1, 5=8-ODD-2)
153	1	C000	INT	0..999	R/W	h	C000 - Compr.1 circ.1 maintenance hour threshold (x100)
154	1	C002	INT	0..2	R/W		C002 - Compr.1 circ.1 manual mode (0=AUTO, 1=OFF, 2=ON)
155	1	C003	INT	0..999	R/W	h	C003 - Compr.2 circ.1 maintenance hour threshold (x100)
156	1	C005	INT	0..2	R/W		C005 - Compr.2 circ.1 manual mode (0=AUTO, 1=OFF, 2=ON)
157	1	C006	INT	0..999	R/W	h	C006 - Compr.1 circ.2 maintenance hour threshold (x100)
158	1	C008	INT	0..2	R/W		C008 - Compr.1 circ.2 manual mode (0=AUTO, 1=OFF, 2=ON)
159	1	C009	INT	0..999	R/W	h	C009 - Compr.2 circ.2 maintenance hour threshold (x100)
160	1	C011	INT	0..2	R/W		C011 - Compr.2 circ.2 manual mode (0=AUTO, 1=OFF, 2=ON)
162	1	C012	INT	30..999	R/W	s	C012 - Compr. min On time
163	1	C013	INT	30..999	R/W	s	C013 - Compr. min Off time
164	1	C014	INT	300..999	R/W	s	C014 - Min time between On of same compr.
165	1	C015	INT	10..999	R/W	s	C015 - Compr. load up time
166	1	C016	INT	5..999	R/W	s	C016 - Compr. load down time
167	1	S021	INT	0..23	R/W	h	Time band hour
168	1	C020	INT	5..999	R/W	min	C020 - Circuit destabilization max time with one or more compr. OFF
169	1	C021	INT	0..1	R/W		C021 - Circuit power distribution (0=Equalized, 1=Grouped)
170	2	C022	REAL	-99.9..99.9	R/W	K/R	C022 - Discharge temp. probe offset for circ.1
172	2	C023	REAL	-99.9..99.9	R/W	K/R	C023 - Suction temp. probe offset for circ.1
174	2	C024	REAL	-99.9..99.9	R/W	K/R	C024 - Discharge temp. probe offset for circ.2
176	2	C025	REAL	-99.9..99.9	R/W	K/R	C025 - Suction temp. probe offset for circ.2
178	2	C026	REAL	-99.9..99.9	R/W	bar	C026 - Discharge press. probe offset for circ.1
180	2	C027	REAL	-99.9..99.9	R/W	bar	C027 - Suction press. probe offset for circ.1
182	2	C028	REAL	-99.9..99.9	R/W	K/R	C028 - Cond. temp. probe offset for circ.1
184	2	C029	REAL	-99.9..99.9	R/W	K/R	C029 - Evap. temp. probe offset for circ.1
186	2	C030	REAL	-99.9..99.9	R/W	bar	C030 - Discharge press. probe offset for circ.2
188	2	C031	REAL	-99.9..99.9	R/W	bar	C031 - Suction press. probe offset for circ.2
190	2	C032	REAL	-99.9..99.9	R/W	K/R	C032 - Cond. temp. probe offset for circ.2
192	2	C033	REAL	-99.9..99.9	R/W	K/R	C033 - Evap. temp. probe offset for circ.2
194	1	C037	INT	0..1	R/W		C037 - Suction press. probe type (0=0..5V, 1=4..20mA)
195	2	C038	REAL	-1.0..99.9	R/W	bar	C038 - Suction press. probe min value
197	2	C039	REAL	0.0..99.9	R/W	bar	C039 - Suction press. probe max value
199	1	C040	INT	0..1	R/W		C040 - Discharge press. probe type (0=0..5V, 1=4..20mA)
200	2	C041	REAL	-1.0..99.9	R/W	bar	C041 - Discharge press. probe min value



Index	Size	Ref.	Type	Min/Max	R/W	UoM	Description
202	2	C042	REAL	0.0..99.9	R/W	bar	C042 - Discharge press. probe max value
204	1	C043	INT	0..1	R/W		C043 - Discharge temp. probe type (0=NTC, 1=NTC-HT)
206	1	C046	INT	1..2	R/W		C046 - Number of circuit in the unit
207	1	C047	INT	0..1/3	R/W		C047 - Type of compressors used (0=1 ON/OFF, 1=2 ON/OFF, 2=BLDC, 3=BLDC + ON/OFF)
208	1	C048	INT	1..2	R/W		C048 - Compressor rotation type (1=FIFO, 2=TIME)
209	1	S000	INT	0..999	R/W	h	S000 - Source pump 1 maintenance hour threshold (x100)
210	1	S002	INT	0..2	R/W		S002 - Source pump 1 manual mode (0=AUTO, 1=OFF, 2=ON)
212	1	S022	INT	0..59	R/W	min	Time band minute
214	1	S008	INT	0..999	R/W	h	S008 - Source fan 1 circ.1 maintenance hour threshold (x100)
215	1	S010	INT	0..2	R/W		S010 - Source fan ON/OFF circ.1 manual mode (0=AUTO, 1=OFF, 2=ON)
216	1	S011	INT	0..101	R/W	%	S011 - Source fan inverter circ.1 manual mode(0=AUTO, 1=0%, 2=1%, .. 101=100%)
217	1	S012	INT	0..999	R/W	h	S012 - Source fan 1 circ.2 maintenance hour threshold (x100)
218	1	S014	INT	0..2	R/W		S014 - Source fan ON/OFF circ.2 manual mode (0=AUTO, 1=OFF, 2=ON)
219	1	S015	INT	0..101	R/W	%	S015 - Source fan inverter circ.2 manual mode (0=AUTO, 1=0%, 2=1%, .. 101=100%)
220	2	S016	REAL	-999.9..999.9	R/W	°C/°F	S016 - Source fan temp. threshold for cold climates
222	2	S017	REAL	0..100	R/W	%	S017 - Source fan min speed for cold climates
224	2	S018	REAL	0..100	R/W	%	S018 - Source fan speed up speed for cold climates
226	1	S019	INT	0..300	R/W	s	S019 - Source fan speed up time for cold climates
227	2		REAL		R/W	%	FC_PrwReq - Free-Cooling regulation ramp
229	2	Sprb	REAL		R	°C/°F	SPrb - Source external air temperature
231	2	S025	REAL	0..999.9	R/W	°C/°F	S025 - Low noise source fan setpoint in cooling
233	1	S026	INT	0..999	R/W	s	S026 - Compr. delay ON since the source pump ON
234	1	S027	INT	0..999	R/W	s	S027 - Source pump delay OFF since the compr. OFF
235	2	S028	REAL	-999.9..999.9	R/W	°C/°F	S028 - Source fan cool setpoint
237	2	S029	REAL	0..99.9	R/W	°C/°F	S029 - Source fan heat setpoint
241	2	S031	REAL	0..999.9	R/W	°C/°F	S031 - Source fan cool setpoint at startup
243	1	S032	INT	0..999	R/W	s	S032 - Source fan cool startup delay
246	2	S034	REAL	0..99.9	R/W	K/R	S034 - Source fan cool differential
248	2	S035	REAL	0..99.9	R/W	K/R	S035 - Source fan heat differential
250	2	S036	REAL	0..100	R/W	%	S036 - Source fan inverter min speed
252	2	S037	REAL	0..100	R/W	%	S037 - Source fan inverter max speed
254	2	S039	REAL	-99.9..99.9	R/W	°C/°F	S039 - Defrost start threshold
256	2	S040	REAL	S039..99.9	R/W	°C/°F	S040 - Defrost start threshold reset
258	1	S041	INT	0..999	R/W	min	S041 - Defrost start delay
259	2	S042	REAL	-999.9..999.9	R/W	°C/°F	S042 - Defrost end threshold
261	1	S044	INT	0..999	R/W	s	S044 - Defrost begin delay before actuating the 4 way valve
262	1	S045	INT	0..999	R/W	s	S045 - Defrost ending delay after actuating the 4 way valve
263	1	S046	INT	0..99	R/W	min	S046 - Defrost min duration
264	1	S047	INT	0..99	R/W	min	S047 - Defrost max duration
265	1	S048	INT	0..999	R/W	s	S048 - Dripping duration
266	1	S049	INT	0..999	R/W	s	S049 - Post dripping duration
267	1	S050	INT	0..999	R/W	min	S050 - Delay between defrosts
272	1	S053	INT	0..2	R/W		S053 - Defrost synchronization type (0=Independent, 1=Separated, 2=Simultaneous)
274	2	S054	REAL	0..999.9	R/W	bar	S054 - Delta press. to reverse the 4 way valve
278	1	S056	INT	20..999	R/W	s	S056 - Duration of smart start function
279	2	S057	REAL	-999.9..999.9	R/W	°C/°F	S057 - Antifreeze source alarm threshold
281	2	S058	REAL	0..999	R/W	K/R	S058 - Antifreeze source alarm differential
283	1	S059	INT	0..999	R/W	s	S059 - Antifreeze source alarm delay time at 1K below threshold
284	2	S060	REAL	-99.9..99.9	R/W	K/R	S060 - Source external air temperature offset
286	1	Hc00	INT	0..3/4	R/W		Hc00 - Analog input 3 config. (0=Not used, 1=Source temp., 2=Discharge temp., 3=Suction temp., 4=Source water delivery temp.)
287	1	Hc01	INT	0..1	R/W		Hc01 - Analog input 4 and 5 config. (0=Pressure, 1=Temp.)
288	1	Hc03	INT	0..2	R/W		Hc03 - Analog input 6 config. (0=Not used, 1=Remote setpoint, 2=Source temp.)
289	1	Hc04	INT	0..1	R/W		Hc04 - Analog input 7 config. (0=Not used, 1=Suction temp.)
290	1	Hc05	INT	0..1	R/W		Hc05 - Analog input 6 config. of Circuit 2 board (0=Not used, 1=Remote setpoint)
291	1	Hc06	INT	0..6	R/W		Hc06 - Digital input 4 config. (0=Not used, 1=Compr.2 circ.1 overload, 2=Remote ON/OFF, 3=Cool/Heat, 4=2nd SetPoint, 5=Remote alarm, 6=User pump 1 overload)
292	1	Hc07	INT	0..6	R/W		Hc07 - Digital input 5 config. (0=Not used, 1=Compr.2 circ.1 overload, 2=Remote ON/OFF, 3=Cool/Heat, 4=2nd SetPoint, 5=Remote alarm, 6=User pump 1 overload)
293	1	Hc08	INT	0..6	R/W		Hc08 - Digital input 6 config. (0=Not used, 1=Compr.2 circ.1 overload, 2=Remote ON/OFF, 3=Cool/Heat, 4=2nd SetPoint, 5=Remote alarm, 6=User pump 1 overload)



Index	Size	Ref.	Type	Min/Max	R/W	UoM	Description
294	1	Hc09	INT	0.5	R/W		Hc09 - Digital input 4 config. of Circuit 2 board (0=Not used, 1=Compr.2 circ.2 overload, 2=Remote ON/OFF, 3=Cool/Heat, 4=2nd SetPoint, 5=User pump 1 overload)
295	1	Hc10	INT	0.5	R/W		Hc10 - Digital input 5 config. of Circuit 2 board (0=Not used, 1=Compr.2 circ.2 overload, 2=Remote ON/OFF, 3=Cool/Heat, 4=2nd SetPoint, 5=User pump 1 overload)
296	1	Hc11	INT	0.5	R/W		Hc11 - Digital input 6 config. of Circuit 2 board (0=Not used, 1=Compr.2 circ.2 overload, 2=Remote ON/OFF, 3=Cool/Heat, 4=2nd SetPoint, 5=User pump 1 overload)
307	2	SEtC	REAL	U006..U007	R/W	°C/°F	SEtC - Cool setpoint
309	2	SEtH	REAL	U008..U009	R/W	°C/°F	SEtH - Heat setpoint
324	2	C017	REAL	0..999.9	R/W	°C/°F	C017 - Threshold of max high pressure (HP)
326	2	C018	REAL	-99.9..99.9	R/W	bar	C018 - Threshold of min low pressure (LP)
328	1	E047	INT	0.2	R/W		E047 - Type of ExV driver (0= Disabled, 1= EVD embedded, 2=EVD EVO)
335	2	P000	REAL	-999.9..999.9	R/W	°C/°F	P000 - Evaporating min temp. custom envelop limit
337	2	P001	REAL	-999.9..999.9	R/W	°C/°F	P001 - Condensing max temp. custom envelop limit
339	1	P002	INT	0..999	R/W	s	P002 - Prevent min duration
340	1	P003	INT	0..999	R/W	s	P003 - Out of envelop alarm delay time
341	1	P004	INT	0..999	R/W	s	P004 - Low pressure difference alarm delay
342	2	P005	REAL	0..999.9	R/W	rps	P005 - Circuit destabilization min BLDC speed threshold
344	2	P006	REAL	0..100	R/W	%	P006 - Oil recovery min request for activation
346	2	P007	REAL	0..999.9	R/W	rps	P007 - Oil recovery min compr. speed for activation
348	1	P008	INT	0..999	R/W	min	P008 - Oil recovery time before activation in which the compressor can run at min speed
349	1	P009	INT	0..999	R/W	min	P009 - Oil recovery duration in which the compr. speed is forced
350	2	P010	REAL	0..999.9	R/W	rps	P010 - Oil recovery compr. speed in which the compr. is forced
352	1	P011	INT	0..999	R/W	s	P011- Oil equalization startup time of solenoid valve on compr. starts
353	1	P012	INT	0..999	R/W	s	P012 - Oil equalization solenoid valve open time
354	1	P013	INT	0..999	R/W	min	P013 - Oil equalization solenoid valve min off time
355	1	P014	INT	0..999	R/W	min	P014 - Oil equalization solenoid valve max off time
356	1	P015	INT	0..999	R/W	min	P015 - Oil equalization max time for the management
357	1	P019	INT	0..101	R/W	%	P019-Compressor 1 circuit 1 manualmode(0=AUTO, 1=0%,... 101=100%)
358	1	P020	INT	0..101	R/W	%	P020-Compressor 1 circuit 2 manualmode(0=AUTO, 1=0%,... 101=100%)
359	2	P021	REAL		R/W	kPa	P021 - Max permitted Delta P to start up
361	1	P022	INT		R/W	s	P022 - Max time of EVD propening to equalize pressure
362	1	P023	INT		R/W	%	P023 - Preopening of EVD in case of prestart to equalize pressure
363	2	P024	REAL		R/W	rps	P024 - Start up speed
365	2	P025	REAL		R/W	rps	P025 - Max speed custom (rps)
367	2	P026	REAL		R/W	rps	P026 - Min speed custom (rps)
369	2	P027	REAL	0..100	R/W	%	P027 - BLDC speed request threshold % to call on it
371	2	P028	REAL	20..100	R/W	%	P028 - BLDC speed threshold to call on fixed speed compressor
373	2	P029	REAL	20..100	R/W	%	P029 - BLDC speed threshold to switch off fixed speed compressor
375	2	P030	REAL		R/W		P030 - Skip frequency: set 1 [010]
377	2	P031	REAL		R/W		P031 - Skip frequency: band 1 [011]
379	1	P032	INT		R/W		P032 - Enable motor over temperature alarm (PTC) (0=OFF, 1=ON) [027]
380	1	P033	INT		R/W		P033 - Motor overtemperature alarm delay [028]
382	2	S051	REAL	0..999.9	R/W	rps	S051 - BLDC defrost speed
384	2	S052	REAL	0..999.9	R/W	rps	S052 - BLDC cycle reverse speed in defrost
703	1		INT		R/W		MotTyp - BLDC Carel Database ID
704	1		INT		R/W		Poles - Number of motor poles
709	1	U079	INT	1..15	R/W	min	U079 - Burst funct. time of user pump on
710	1	U080	INT	3..99	R/W	min	U080 - Burst funct. time of user pump off
732	2	S070	REAL	-99.9..99.9	R/W	K/R	S070 - Cond.1 antifreeze temp. probe offset (S3)
734	2	S071	REAL	99.9..99.9	R/W	K/R	S071 - Cond.2 antifreeze temp. probe offset (S3 exp.)
736	2	S069	REAL	0..99.9	R/W	°C/°F	S069 - Temperature set point of Fan-Defrost function (0=Function di



7.4 Input register

Index	Size	Ref.	Type	Min/Max	R/W	UoM	Description
0	2	HuP1	INT		R	h	HuP1 - User pump 1 working hours
2	2	HuP2	INT		R	h	HuP2 - User pump 2 working hours
4	2	H1C1	INT		R	h	H1C1 - Compr.1 circ.1 working hour
6	2	H1C2	INT		R	h	H1C2 - Compr.2 circ.1 working hour
8	2	H2C1	INT		R	h	H2C1 - Compr.1 circ.2 working hour
10	2	H2C2	INT		R	h	H2C2 - Compr.2 circ.2 working hour
12	2	dSt1	REAL		R	°C/°F	dSt1 - Discharge temp. probe of circ.1
14	2	Sct1	REAL		R	°C/°F	Sct1 - Suction temp. of circ.1
16	2	dSt2	REAL		R	°C/°F	dSt2- Discharge temp. probe of circ.2
18	2	Sct2	REAL		R	°C/°F	Sct2 - Suction temp. of circ.2
20	2	dSP1	REAL		R	bar/psi	dSP1 - Discharge press. probe of circ.1
22	2	ScP1	REAL		R	bar/psi	ScP1 - Suction press. of circ.1
24	2	Cnd1	REAL		R	°C/°F	Cnd1 - Cond. temp. probe (or press. probe converted value) of circ.1
26	2	EuP1	REAL		R	°C/°F	EuP1 - Evap. temp. probe (or press. probe converted value) of circ.1
28	2	dSP2	REAL		R	bar/psi	dSP2 - Discharge press. probe of circ.2
30	2	ScP2	REAL		R	bar/psi	ScP2 - Suction press. of circ.2
32	2	Cnd2	REAL		R	°C/°F	Cnd2 - Cond. temp. probe (or press. probe converted value) of circ.2
34	2	EuP2	REAL		R	°C/°F	EuP2 - Evap. temp. probe (or press. probe converted value) of circ.2
36	2	HSP1	INT		R	h	HSP1 - Source pump 1 working hours
38	1	C045	INT		R		C045 - Refrigerant type (3=R407C, 4=R410a, 6=R290, 10=R744, 22=R32)
40	2	HFf1	INT		R	h	HFf1 - Source fan 1 circ.1 working hour
42	2	HFf2	INT		R	h	HFf2 - Source fan 1 circ.2 working hour
46	2	SEtA	REAL		R	°C/°F	SEtA - Actual setpoint used by thermoregulation
48	2	SSH1	REAL		R	K/R	SSH1 - Suction Superheat of circ.1
50	1	Opn1	INT		R	%	Opn1 - EEV position of circ.1
51	2	SSH2	REAL		R	K/R	SSH2 - Suction Superheat of circ.2
53	1	Opn2	INT		R	%	Opn2 - EEV position of circ.2
54	2	rUSr	REAL		R	°C/°F	rUSr - Return water temp. from user
56	2	dUSr	REAL		R	°C/°F	dUSr - Delivery water temperature to user
65	2		REAL		R	%	Fan1Req - Inverter request source fan circ.1
67	2		REAL		R	%	Fan2Req - Inverter request source fan circ.2
71	1		INT		R		UnitStatus- Unit status (0=OFF by remote DI, 1=OFF by keyboard, 2=OFF by scheduler, 3=OFF by BMS, 4=OFF by changeover mode Ch/HP, 5=OFF by alarm, 6=Unit in defrosting, 7=Unit ON, 8=Manual mode)
90	2	rSPt	REAL		R	°C/°F	rSPt - Remote set point
92	2		REAL		R	%	PwrReq - Power request
96	2		REAL		R	°C/°F	SrcSetP_Circ1 - Source fan circ.1 set point
98	2		REAL		R	°C/°F	SrcSetP_Circ2 - Source fan circ.2 set point
100	2	rps1	REAL		R	rps	PSD circuit 1: Actual rotor speed coming from inverter
102	2	Mc1	REAL		R	A	PSD circuit 1: Current motor current [A]
104	2	MP1	REAL		R	kW	PSD circuit 1: Current motor consumption [kW]
106	2	Drt1	REAL		R	°C/°F	PSD circuit 1: Current drive temperature[°C]
108	1	AIHs1_1	INT		R		PSD circuit 1: the last alarm log
109	1	AIHs2_1	INT		R		PSD circuit 1: the last-but-1st alarm log
110	1	AIHs3_1	INT		R		PSD circuit 1: the last-but-2nd alarm log
111	1	AIHs4_1	INT		R		PSD circuit 1: the last-but-3rd alarm log
114	1		INT		R		MotTyp - BLDC circ.1 Carel Database ID
115	1		INT		R		Envelope zone circ.1
116	2		REAL		R	°C/°F	EnvPnt_X1 - Envelope point
118	2		REAL		R	°C/°F	EnvPnt_Y1 - Envelope point
120	2		REAL		R	°C/°F	EnvPnt_X2 - Envelope point
122	2		REAL		R	°C/°F	EnvPnt_Y2 - Envelope point
124	2		REAL		R	°C/°F	EnvPnt_X3 - Envelope point
126	2		REAL		R	°C/°F	EnvPnt_Y3 - Envelope point
128	2		REAL		R	°C/°F	EnvPnt_X4 - Envelope point
130	2		REAL		R	°C/°F	EnvPnt_Y4 - Envelope point
132	2		REAL		R	°C/°F	EnvPnt_X5 - Envelope point
134	2		REAL		R	°C/°F	EnvPnt_Y5 - Envelope point
136	2		REAL		R	°C/°F	EnvPnt_X6 - Envelope point
138	2		REAL		R	°C/°F	EnvPnt_Y6 - Envelope point
140	2		REAL		R	°C/°F	EnvPnt_X7 - Envelope point
142	2		REAL		R	°C/°F	EnvPnt_Y7 - Envelope point
144	2		REAL		R	°C/°F	EnvPnt_X8 - Envelope point



Index	Size	Ref.	Type	Min/Max	R/W	UoM	Description
146	2		REAL		R	°C/°F	EnvPnt_Y8 - Envelope point
148	1		INT		R		Envelope zone circ.2
149	2		REAL		R	°C/°F	EnvPnt2_X1 - Envelope point
151	2		REAL		R	°C/°F	EnvPnt2_Y1 - Envelope point
153	2		REAL		R	°C/°F	EnvPnt2_X2 - Envelope point
155	2		REAL		R	°C/°F	EnvPnt2_Y2 - Envelope point
157	2		REAL		R	°C/°F	EnvPnt2_X3 - Envelope point
159	2		REAL		R	°C/°F	EnvPnt2_Y3 - Envelope point
161	2		REAL		R	°C/°F	EnvPnt2_X4- Envelope point
163	2		REAL		R	°C/°F	EnvPnt2_Y4 - Envelope point
165	2		REAL		R	°C/°F	EnvPnt2_X5 - Envelope point
167	2		REAL		R	°C/°F	EnvPnt2_Y5 - Envelope point
169	2		REAL		R	°C/°F	EnvPnt2_X6 - Envelope point
171	2		REAL		R	°C/°F	EnvPnt2_Y6 - Envelope point
173	2		REAL		R	°C/°F	EnvPnt2_X7 - Envelope point
175	2		REAL		R	°C/°F	EnvPnt2_Y7 - Envelope point
177	2		REAL		R	°C/°F	EnvPnt2_X8 - Envelope point
179	2		REAL		R	°C/°F	EnvPnt2_Y8 - Envelope point
181	2	rps2	REAL		R	rps	PSD circuit 2: Actual rotor speed coming from inverter
183	2	Mc2	REAL		R	A	PSD circuit 2: Current motor current [A]
185	2	MP2	REAL		R	kW	PSD circuit 2: Current motor consumption [kW]
187	2	Drt2	REAL		R	°C/°F	PSD circuit 2: Current drive temperature[°C]
189	1	AlHs1_2	INT		R		PSD circuit 2: the last alarm log
190	1	AlHs2_2	INT		R		PSD circuit 2: the last-but-1st alarm log
191	1	AlHs3_2	INT		R		PSD circuit 2: the last-but-2nd alarm log
192	1	AlHs4_2	INT		R		PSD circuit 2: the last-but-3rd alarm log
193	1		INT		R		MotTyp2 - BLDC circ.2 Carel Database ID
213	2	AFC2	REAL		R	°C/°F	AFC2 - Cond.2 antifreeze temp (S3 exp.)
217	2	AFC1	REAL		R	°C/°F	AFC1 - Cond.1 antifreeze temp (S3)



8. Alarms and signals

The controller manages three types of alarms, depending on the reset mode:

- **A - automatic:** the alarm is reset and the device restarts automatically when the alarm condition is no longer present;
- **R - semi-automatic:** if the alarm occurs several times, reset becomes manual and an operator needs to physically restart the device.
- **M - manual:** an operator an operator needs to physically restart the device.

Alarms that require technical service are shown on the display with the flashing spanner icon.

If the spanner icon is on, it means that a device has reached the programmed operating hour threshold, and maintenance is required (the alarm code indicates which device is affected).

For some alarms, the reset mode can be configured by parameter. The configurable alarms are:

- High pressure switch
- Low pressure switch
- Frost protection alarm

Use	Cod	Description	De	Mi	M	UO
M	U081	Pressure-frost alarm reset configuration 0 = high pressure switch, low pressure switch, frost all with manual reset 1 = high pressure switch, low pressure switch, frost all with automatic reset 2 = high pressure and switch and frost with manual reset, low pressure switch with automatic reset 3 = high pressure switch with manual reset, low pressure switch, and frost with automatic reset 4 = high pressure switch and low pressure switch with manual reset, frost with automatic reset 5 = high pressure switch and low pressure switch with semi-automatic reset, frost with automatic reset 6 = high pressure switch and low pressure switch with semi-automatic reset, frost with manual reset 7 = high pressure and switch and frost with manual reset, low pressure switch with semi-automatic reset	7	0	7	-

8.1 Active alarms

🔊 Note: the user terminal can only access the active alarms without password protection, or, with password protection, to the alarms relating to unit initialization and optimization.

Active alarms are signalled by buzzer and the Alarm button lighting up. Pressing Alarm mutes the buzzer and displays the alarm code (on the top row) and any additional information (on the bottom row). Alarm activation is recorded in the alarm log.

If the alarm is reset automatically, the Alarm button goes off, the alarm code is cleared from the list and the alarm reset event is recorded in the alarm log.

Procedure (alarm acknowledgement):

1. press Alarm: the buzzer is muted, the alarm code is shown on the display;
2. press UP/DOWN to scroll through the list of alarms;
3. when finished, press Esc and then PRG to exit.

Procedure



When an alarm is active, the buzzer sounds and the Alarm button lights up



Pressing Alarm mutes the buzzer and displays the alarm code; pressing UP/ DOWN scrolls the list of any other alarms.



When reaching the end of the alarm list, "ESC" is shown: press PRG to exit the alarm list.



Pressing the Alarm button for more than 3 s resets the alarms: noAL indicates that there are no more active alarms. Press PRG to exit the alarm list

A single alarm can be reset by pressing Alarm for more than 3 s. If the condition that generated the alarm is still present, the alarm will be reactivated. The alarm log can be deleted using parameter ClrH, accessible via the Service level on the terminal or APPLICA via smartphone, with BLE connection, using the specific function on the alarm page ("Service" level access). The same operations can be performed with APPLICA via smartphone, using the specific function on the alarm page (a BLE connection and "Service" level access are required).

 **Note:**

- deletion of the alarm log is irreversible;
- see chapter "Functions" for the alarm parameters: evaporator outlet temperature, frost protection, compressor;
- the buzzer is activated for all alarms



8.2 Active alarms list

Code	Description	Reset	Effect	Priority	Delay	No. of attempt	Evaluation p.
A01	Unit: no. of permanent memory writes	M	-	Fault	No	-	-
A02	Unit: permanent memory writes	M	-	Fault	No	-	-
A03	Unit: remote alarm from digital input	M	Unit shutdown	Serious, unit	No	-	-
A04	Unit: remote set point probe	A	Use standard set point	Fault	10s	-	-
A05	Unit: user return water temperature probe	A	Unit shutdown	Fault	10s	-	-
A06	Unit: user delivery water temperature probe	A	Unit shutdown	Serious, unit	10s	-	-
A08	Unit: user pump 1 overload	M	-	Fault	No	-	-
A09	Unit: user pump 2 overload	M	-	Fault	No	-	-
A10	Unit: flow switch (with user pump 1 active)	M	Unit shutdown	Serious, unit	Param. U045/U046	-	-
A11	Unit: flow switch (with user pump 2 active)	M	Unit shutdown	Serious, unit	Param. U045/U046	-	-
A12	Unit: user pump group	M	Unit shutdown	Serious, unit	No	-	-
A13	Unit: user pump 1 maintenance	A	Fault	Param.	U000	-	-
A14	Unit: user pump 2 maintenance	A	-	Fault	Param. U003	-	-
A15	Unit: high chilled water temperature	A	-	Fault	Param. U032/U033	-	-
A16	Unit: sourcereturn water/air temperature probe	A	Disable FC and Compensation (A/W units)	Fault	10s	-	-
A17	Unit: source pump 1 maintenance	A	-	Fault	Param. S000	-	-
A18	Unit: free cooling warning	M	Disable FC	Fault	Param. U032/180s	-	-
A19	Circuit 1: condensation pressure probe	A	Circuit 1 shutdown	Serious, circuit 1	10s	-	-
A20	Circuit 1: condensing temperature probe	A	Circuit 1 shutdown	Serious, circuit 1	10s	-	-
A21	Circuit 1: evaporation pressure probe	A	Circuit 1 shutdown	Serious, circuit 1	10s	-	-
A22	Circuit 1: evaporation temperature probe	A	Circuit 1 shutdown	Serious, circuit 1	10s	-	-
A23	Circuit 1: discharge temperature probe	A	Circuit 1 shutdown	Serious, circuit 1	10s	-	-
A24	Circuit 1: suction temperature probe	A	Circuit 1 shutdown	Serious, circuit 1	10s	-	-
A25	Circuit 1: high pressure switch	Param. U081.	Circuit 1 shutdown	Serious, circuit 1	No	-	-
A26	Circuit 1: high condensing pressure/temperature transducer	M	Circuit 1 shutdown	Serious, circuit 1	No	-	-
A27	Circuit 1: low pressure transducer	A (R)	Circuit 1 shutdown	Serious, circuit 1	No	3	3600
A28	Circuit 1: frost protection evaporation temperature	Param. U081	Circuit 1 shutdown	Serious, circuit 1	Param. U052	-	-
A29	Circuit 1: compressor 1 overload	Param. U081	Circuit 1 shutdown	Serious, circuit 1	Param. C049, C050	3	3600
A30	Circuit 1: compressor 2 overload	M	Comp. 1 circ. 1 shutdown	Fault, circuit 1	No	-	-
A31	Circuit 1: compressor 1 maintenance	M	Comp. 2 circ. 1 shutdown	Fault, circuit 1	No	-	-
A32	Circuit 1: compressor 2 maintenance	A	-	Fault, circuit 1	Param. C000	-	-
A33	Circuit 1: source fan maintenance	A	-	Fault, circuit 1	Param. C003	-	-
A34	EVD circuit 1: LowSH	A	-	Fault, circuit 1	Param. S008	-	-
A35	EVD circuito 1: LowSH	M	Circuit 1 shutdown	Fault, circuit 1	Param. E024	-	-
A36	EVD circuit 1: LOP	A	-	Fault, circuit 1	Param. E025	-	-
A37	EVD circuit 1: MOP	A	Circuit 1 shutdown	Fault, circuit 1	Param. E026	-	-
A38	EVD circuit 1: motor error	M	Circuit 1 shutdown	Fault, circuit 1	No	-	-
A39	EVD circuit 1: emergency closing	A	-	Fault, circuit 1	No	-	-
A40	EVD circuit 1: incomplete valve closing	A	-	Fault, circuit 1	No	-	-
A41	EVD circuit 1: offline	A	Circuit 1 & 2 shutdown	Serious, circuit 1 & 2	30s	-	-
A42	Circuit 1: envelope alarm + zone alarm	A (R)	Circuit 1 shutdown	Serious, circuit 1	Param. P003	3	3600
A43	BLDC circuit 1: high pressure differential at start-up	A	BLDC 1 not enabled to start	Serious, circuit 1	5min	-	-
A44	BLDC circuit 1: failed start-up	A (R)	-	Serious, circuit 1	45s	5	3600
A45	BLDC circuit 1: low pressure differential	A	Circuit 1 shutdown	Serious, circuit 1	Param. P004	-	-
A46	BLDC circuit 1: high gas discharge temp.	M	Circuit 1 shutdown	Serious, circuit 1	No	-	-
A47	Speed drive 1: offline	A	Circuit 1 shutdown / BLDC 1	Serious, circuit 1	30s	-	-
A48	Speed drive 1: alarm + error code	A (R)	Circuit 1 shutdown / BLDC 1	Serious, circuit 1	No	3	3600
A49	Unit: circuit 2 offline	A	-	Serious, circuit 2	30s	-	-
A50	Circuit 2 unit: no. permanent memory writes	M	-	Fault	No	-	-



Code	Description	Reset	Effect	Priority	Delay	No. of attempt	Evaluation p.
A51	Circuit 2 unit: permanent memory writes	M	-	Fault	No	-	-
A52	Circuit 2: condensation pressure probe	A	Circuit2shutdown	Serious, circuit2	10s	-	-
A53	Circuit 2: condensing temperature probe	A	Circuit2shutdown	Serious, circuit2	10s	-	-
A54	Circuit 2: evaporation pressure probe	A	Circuit2shutdown	Serious, circuit2	10s	-	-
A55	Circuit 2: evaporation temperature probe	A	Circuit2shutdown	Serious, circuit2	10s	-	-
A56	Circuit 2: discharge temperature probe	A	Circuit2shutdown	Serious, circuit2	10s	-	-
A57	Circuit 2: suction temperature probe	A	Circuit2shutdown	Serious, circuit2	10s	-	-
A58	Circuit 2: high pressure switch	Param. U081	Circuit2shutdown	Serious, circuit2	No	-	-
A59	Circuit 2: high condensing pressure/temperature transducer	M	Circuit2shutdown	Serious, circuit2	No	-	-
A60	Circuit 2: low pressure transducer	A (R)	Circuit2shutdown	Serious, circuit2	No	3	3600
A61	Circuit 2: frost protection evaporation temperature	Param. U081	Circuit2shutdown	Serious, circuit2	Param. U052	-	-
A62	Circuit 2: low pressure switch	Param. U081	Circuit2shutdown	Serious, circuit2	Param. C049, C050	3	3600
A63	Circuit 2: compressor 1 overload	M	Comp. 1 circ. 2 shutdown	Fault, circuit 2	No	-	-
A64	Circuit 2: compressor 2 overload	M	Comp. 2 circ. 2 shutdown	Fault, circuit 2	No	-	-
A65	Circuit 2: compressor 1 maintenance	A	-	Fault	Param. C006	-	-
A66	Circuit 2: compressor 2 maintenance	A	-	Fault	Param. C003	-	-
A67	Circuit 2: source fan maintenance	A	-	Fault	Param. S012	-	-
A68	EVD circuit 2: LowSH	M	Circuit2shutdown	Serious, circuit2	Param. E024	-	-
A69	EVD circuit 2: LOP	A	Circuit2shutdown	Serious, circuit2	Param. E025	-	-
A70	EVD circuit 2: MOP	A	Circuit2shutdown	Serious, circuit2	Param. E026	-	-
A71	EVD circuit 2: motor error	M	Circuit2shutdown	Serious, circuit2	No	-	-
A72	EVD circuit 2: emergency closing	A	Circuit2shutdown	Serious, circuit2	No	-	-
A73	EVD circuit 2: incomplete valve closing	A	Circuit2shutdown	Serious, circuit2	No	-	-
A74	EVD circuit 2: offline	A	Circuit2shutdown	Serious, circuit2	30s	-	-
A75	Circuit 2: envelope alarm + zone alarm	A (R)	Circuit2shutdown	Serious, circuit2	Param. P003	3	3600
A76	BLDC circuit 2: high pressure differential at start-up	A	BLDC 2 not enabled to start	Serious, circuit2	5min	-	-
A77	BLDC circuit 2: failed start-up	A (R)	-	Serious, circuit2	45	5	3600
A78	BLDC circuit 2: low pressure differential	A	Circuit2shutdown	Serious, circuit2	P004	-	-
A79	BLDC circuit 2: high gas discharge temp.	M	Circuit2shutdown	Serious, circuit2	No	-	-
A80	Speeddrive circuit 2: offline	A	Comp. 1 circ. 2 shutdown	Serious, circuit2	30s	-	-
A81	Speed drive circuit 2: alarm +code error	A (R)	Comp. 1 circ. 2 shutdown	Serious, circuit2	No	3	3600
A87	Unit: EVD Evolution not compatible	A	Unit shutdown	Serious, unit	No	-	-



9. Technical specifications

Model	UCHBP* (panel models)	UCHBD* (DIN rail models)
Physical specifications		
Dimensions	See figures	See figures
Case	Polycarbonate	Polycarbonate
Assembly	panel	DIN rail
Ball pressure test temperature	125°C	125°C
Ingress protection	IP20 (rear) - IP65 (front)	IP00
Front cleaning	Use soft, non-abrasive cloth and neutral detergent or water	-
Environmental conditions		
Storage conditions	-40T85°C, <90 % RH non-condensing	-40T85°C, <90 % RH non-condensing
Operating conditions	-20T60°C, <90 % RH non-condensing	-20T60°C, <90 % RH non-condensing
Electrical specifications		
Rated power supply	24 Vac/dc (SELV or PELV power supply, Class 2)	24 Vac/dc (SELV or PELV power supply, Class 2)
Operating power supply voltage	24 Vac/dc, +10% -15%	24 Vac/dc, +10% -15%
Input frequency (AC)	50/60 Hz	50/60 Hz
Maximum current draw	600 mA rms	DIN without ExV valve driver: 600 mA rms DIN with ExV valve driver: 1.25 Arms
Absorbed power for transformer sizing	15 VA	Models without valve driver: 15 VA Models with valve driver: 30 VA
Clock	precision: ± 50 ppm; min time maintenance after power off: 72 h	precision: ± 50 ppm; min time maintenance after power off: 72 h
Software class and structure	A	A
Pollution degree	3	3
Class of protection against electric shock	To be incorporated in class I or II appliances	To be incorporated in class I or II appliances
Type of action and disconnection	1.C	1.C
Rated impulse voltage	relay outputs: 4 kV; 24 V input: 0.5 kV	relay outputs: 4 kV; 24 V input: 0.5 kV
Surge immunity category	relay outputs: III; input 24V: II	relay outputs: III; input 24V: II
Control device construction	Device to be incorporated	Device to be incorporated
Terminal block	Plug-in male-female. Wire sizes: see the connector table	Plug-in male-female. Wire sizes: see the connector table
Purpose of the controller	Electrical operating control	Electrical operating control
User interface		
Buzzer	Integrated	not included on the controller, built into the user terminal
Display	LED 2 rows, decimal point, and multi-function icons	LED 2 rows, decimal point, and multi-function icons
Connectivity		
NFC	Max distance 10mm, variable according to the mobile device used	Max distance 10mm, variable according to the mobile device used
Bluetooth Low Energy	Max distance 10m, variable according to the mobile device used	Max distance 10m, variable according to the mobile device used
BMS serial interface	Modbus over RS485, not opto-isolated	Modbus over RS485, not opto-isolated
FieldBUS serial interface	Modbus over RS485, not opto-isolated	Modbus over RS485, not opto-isolated
HMI interface	Modbus over RS485, not opto-isolated	Modbus over RS485, not opto-isolated



Analogue inputs (Lmax=10m)

J2 S1, S2, S3: NTC S5: 0-5V ratiometric / 4-20 mA / NTC	NTC: resolution 0.1 °C; 10Kohm @ 25 °C, error:±1°C in the range -50T50°C, ±3°C in the range 50T90°C;	NTC: resolution 0.1 °C; 10Kohm @ 25 °C, error:±1°C in the range -50T50°C, ±3°C in the range 50T90°C;
J3 S4: 0-5 V ratiometric / 4-20 mA / NTC S6: 0-5 V ratiometric / 0-10V / 4-20 mA / NTC	0-5 V ratiometric: error 2% fs, typical 1%; 4-20mA: error 5% fs, typical 1% 0-10 V: error 2% fs, typical 1%	0-5 V ratiometric: error 2% fs, typical 1%; 4-20mA: error 5% fs, typical 1% 0-10 V: error 2% fs, typical 1%
J9 S7: NTC (DIN version only)	-	NTC: resolution 0.1 °C; 10Kohm @ 25 °C, error:±1°C in the range -50T50°C, ±3°C in the range 50T90°C;

Digital inputs (Lmax=10m)

Model	UCHBP* (panel models)	UCHBD* (DIN rail models)
J2	ID1(*)	Voltage-free contact, not optically-isolated, typical closing current 6 mA, voltage with contact open 13 V, max contact resistance 50Ω (*) Fast digital input: 0-2 kHz; error 2% fs
J2	ID2	
J3	ID3(*), ID4, ID5	
J9	D6 - avail. only on DIN version	

Valve output

	UCHBP* (panel models)	UCHBD* (DIN rail models)
J14	Available only on DIN version	CAREL E*V unipolar valve power supply: 13 Vdc, min winding resistance 40 Ω

Analogue outputs (Lmax=10m)

J14	Y1, Y2
-----	--------

Digital outputs (Lmax=10m)

🔊 **Note:** the sum of current draw on NO1, NO2, NO3 and NO4 must not exceed 8 A

J6 NO1(5A), NO2(5A), NO3(5A), NO4(5A)	5A: EN60730: 5A resistive, 250Vac, 50k cycles; 4(1), 230Vac, 100k cycles; 3 (1), 230Vac, 100k cycles UL60730: 5A resis., 250Vac, 30k cycles; 1FLA, 6LRA, 250Vac, 30k cycles; Pilot Duty C300, 30k cycles	5A: EN60730: 5A resistive, 250Vac, 50k cycles; 4(1), 230Vac, 100k cycles; 3 (1), 230Vac, 100k cycles UL60730: 5A resis., 250Vac, 30k cycles; 1FLA, 6LRA, 250Vac, 30k cycles; Pilot Duty C300, 30k cycles
J7 NO5(5A)		
J11 NO6(5A) - only for DIN		

Emergency power supply

J10: Ultracap module (optional, available only on DIN version)	13 Vdc ±10%
--	-------------

Probe and terminal powersupply (Lmax=10m)

5V	5 Vdc ± 2% to power the 0 to 5 V ratiometric probes. Maximum current delivered: 35 mA protected against short-circuits	5 Vdc ± 2% to power the 0 to 5 V ratiometric probes. Maximum current delivered: 35 mA protected against short-circuits
+V	8-11 V to power the 4-20 mA current probes. Maximum current delivered: 80 mA protected against short-circuits	8-11 V to power the 4-20 mA current probes. Maximum current delivered: 80 mA protected against short-circuits
VL	Not used	Not used
J8	User terminal power supply	User terminal power supply

Serialports

BMS	<ul style="list-style-type: none"> • Integrated • Protocol: Modbus 	<ul style="list-style-type: none"> • Integrated • Protocol: Modbus
Lmax=500 m, shielded cable (RS485 1½ twisted pair) (1)	<ul style="list-style-type: none"> • HW driver: asynchronous half duplex RS 485 Circ. 2 • Not optically-isolated • 3-pin plug-in connector, 3.81 mm pitch • Max data rate: 115200 bit/s • Max number of connectable devices: 16 	<ul style="list-style-type: none"> • HW driver: asynchr.half duplex RS 485 Circ. 2 • Not optically-isolated • 3-pin plug-in connector, 3.81 mm pitch • Max data rate: 115200 bit/s • Max number of connectable devices: 16



Model	UCHBP* (panel models)	UCHBD* (DIN rail models)
Fieldbus J5: Lmax=10 m, shielded cable (RS485 1½ twisted pair) (1)	<ul style="list-style-type: none"> • Integrated • HW driver: asynchronous half duplex RS 485 Circuit 1. Typical reception resistance 96 kohms, equal to 1/8 of unit load, i.e. 1/256 of maximum load applicable on the line • Not optically-isolated • Max data rate: 19200 bit/s • Maximum number of connectable devices: 16 • Protocol: Modbus RTU 	<ul style="list-style-type: none"> • Integrated • HW driver: asynchr.half duplex RS 485 Circuit 1. Typical reception resistance 96 kohms, equal to 1/8 of unit load, i.e. 1/256 of maximum load applicable on the line • Not optically-isolated • Max data rate: 19200 bit/s • Max number of connectable devices: 16 • Protocol: Modbus RTU

Cable lengths

Analogue inputs/outputs, digital inputs / outputs, probe power	<10m (*) (*) in the panel version, if using the +13 V power supply in domestic environments, the maximum cable length is 2 m.	
Valve	< 2 m, < 6 m with shielded cable	< 2 m, < 6 m with shielded cable
BMS and Fieldbus serial cables	<500m with shielded cable	<500m with shielded cable

Conformity

Electrical safety	EN/UL 60730-1, EN/UL 60335-1	EN/UL 60730-1, EN/UL 60335-1
Electromagnetic compatibility	EN 61000-6-1, EN 61000-6-2, EN 61000-6-3, EN 61000-6-4	EN 61000-6-1, EN 61000-6-2, EN 61000-6-3, EN 61000-6-4
Applications with flammable refrigerant gases	EN/UL 60079-15, EN/UL 60335-2-34, EN/UL 60335-2-40, EN/UL 60335-2-89	EN/UL 60079-15, EN/UL 60335-2-34, EN/UL 60335-2-40, EN/UL 60335-2-89
Wireless compliance	RED, FCC, IC	RED, FCC, IC

🔊 **Note: (1)** it is recommended to use a BELDEN 8761 cable (AWG 22).

9.1 Connector/cable table

Ref.	Description	Wiring terminals	Wire cross Section (mm ²)	Lmax (m)
J1	Controller power supply	Panel model: plug-in terminal, screw, 2-pin, pitch 5.08 DIN rail model: plug-in terminal, screw, 2-pin, pitch 5.08	0.5...1.5 0.21...3.31	10
J2	Inputs S1, S2, S3, S5, ID1, ID2; outputs Y2, Y2	10-pin Microfit crimp connector	0.05...0.52	10
J3	Inputs S4, S6, ID3, ID4, ID5	8-pin Microfit crimp connector	0.05...0.52	10
J4	BMS	Plug-in screw terminal, 3-pin, pitch 3.81	0.081...1.31	500
J5	Fbus	Plug-in screw terminal, 3-pin, pitch 3.81	0.081...1.31	10
J6	Outputs NO1, NO2, NO3, NO4	6-pin Microfit crimp connector	0.5...1.31	10
J7	Output NO5	3-pin Microfit crimp connector	0.5...1.31	10
J8	Unit terminal	Connection cable P/N: ACS00CB000010 (L=3m)-/20 (L=1.5m)	0.13	2*
J9	Inputs S7, ID6	4-pin Microfit crimp connector	0.05...0.52	10
J10	Ultracap	3-pin JST connector	0.13	2
J11	Output NO6	3-pin Microfit crimp connector	0.5...1.31	10
J14	Unipolar ExV valve	CAREL ExV unipolar valve connector, pre-wired	-	2, 6 with shield. cable

