

Code	
9828093663	02
Edit. 07/2024	

INSTRUCTION AND MAINTENANCE MANUAL

DRYERS

T60 – T80 – T95 – T125
T150 – T190 – T240 – T300

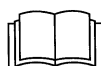
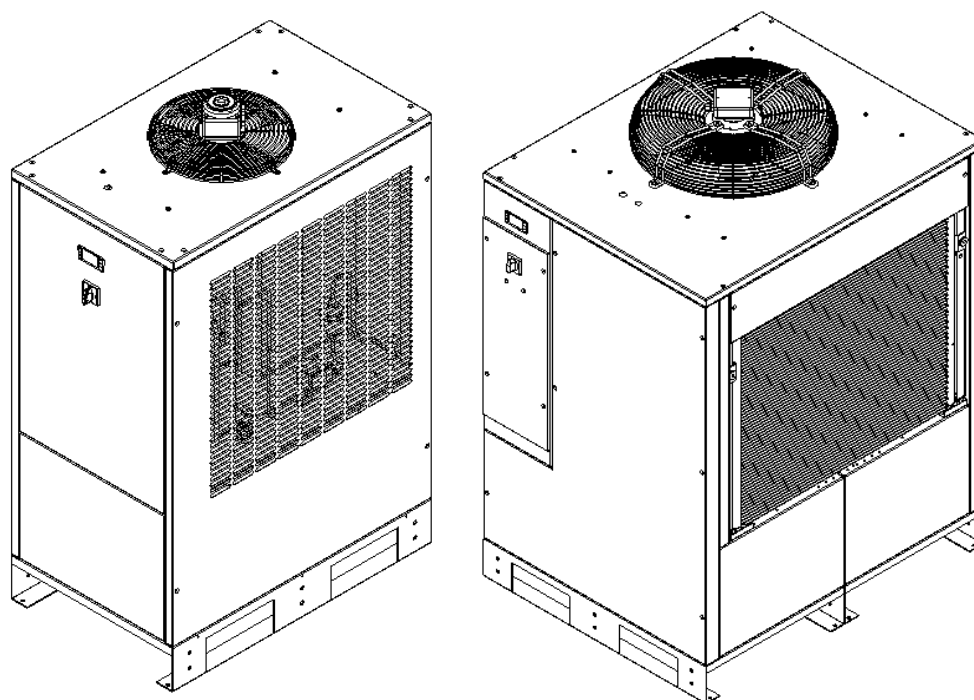

READ THIS MANUAL CAREFULLY BEFORE CARRYING OUT ANY OPERATIONS ON THE DRYER.

CONTENTS

PART A: INFORMATION FOR THE USER

- 1.0 GENERAL CHARACTERISTICS
- 2.0 INTENDED USE
- 3.0 OPERATION
- 4.0 GENERAL SAFETY STANDARDS
- 5.0 DESCRIPTION OF DANGER SIGNALS
- 6.0 DANGER ZONES
- 7.0 SAFETY DEVICES
- 8.0 POSITION OF PLATES
- 9.0 DRYERS ROOM
- 10.0 TRANSPORT AND HANDLING
- 11.0 UNPACKING
- 12.0 INSTALLATION
- 13.0 DIMENSIONS AND TECHNICAL DATA
- 14.0 MACHINE ILLUSTRATION
- 15.0 SCRAPPING THE UNIT

PART B: INFORMATION RESERVED FOR TECHNICALLY SKILLED PERSONNEL

- 16.0 ROUTINE MAINTENANCE
- 17.0 TROUBLE-SHOOTING AND EMERGENCY REMEDIES
- 18.0 STARTING UP, FREE CONTACT FEATURES

ATTENTION: THERE IS A COPY OF THE WIRING DIAGRAM INSIDE THE ELECTRIC PANEL

ADDRESSES OF ASSISTANCE CENTRES

In the event of breakdown or malfunction of the dryer, switch it off and do not tamper with it. If repairs are needed, apply only to a technical assistance centre approved by the manufacturer and insist on the use of original spare parts. Failure to comply with the above may endanger the safety of the machine.

INTRODUCTION

Keep this manual with care for future consultation; the use and maintenance manual is an integral part on the dryer. Read this manual carefully before carrying out any operations on the dryer.

The installation of the dryer and all operations involving it must be performed in conformity with the regulations in force concerning electric plants and personal safety.

CHARACTERISTICS AND SAFETY PRECAUTIONS



**BEFORE REMOVING THE PROTECTIVE GUARDS TO CARRY OUT ANY MAINTENANCE ON THE MACHINE, SWITCH OFF THE ELECTRIC POWER SUPPLY AND DISCHARGE THE RESIDUAL PRESSURE INSIDE THE UNIT.
ALL WORK ON THE ELECTRIC PLANT, HOWEVER SLIGHT, MUST BE CARRIED OUT BY PROFESSIONALLY SKILLED PERSONNEL.**

The manufacturer does not accept responsibility for damage caused as a result of negligence or failure to abide by the instructions given above.

THIS MACHINE IS NOT SUITABLE FOR EXTERNAL INSTALLATION

THIS MACHINE CORRESPOND TO THE ESSENTIAL SAFETY REQUIREMENTS FORESEEN FROM THE EUROPEAN STANDARD (2006/42 CE).

THE LUBRICATING LIQUIDS, THE THERMAL MASS FLUID AND OTHER EVENTUAL FLUIDS MUST NOT BE DISCHARGED IN THE ENVIRONMENT. THESE POLLUTING AND HAZARDOUS PRODUCTS MUST COMPULSORY BE DISPOSED BY CHARGING AUTHORISED AND SPECIALISED FIRMS ACCORDING TO THE DIFFERENT TYPOLOGY OF PRODUCT.

DIFFERENTIATE THE COMPRESSOR COMPONENTS ACCORDING TO THE DIFFERENT CONSTRUCTION MATERIALS (PLASTIC, COPPER, IRON, OIL FILTER, AIR FILTER ECC...)



THE THERMAL MASS FLUID USED IN THE DRYER CONTAINS ETHYLENE GLYCOL. IT IS HARMFUL IF SWALLOWED AND MAY CAUSE DAMAGE TO ORGANS (KIDNEYS, LIVER) THROUGH PROLONGED OR REPEATED EXPOSURE

1.0 GENERAL CHARACTERISTICS

The thermal mass dryer is a chilling machine uses a secondary fluid to cool down compressed air and separate the moisture in order to reduce the pressure dew point avoiding water in the air net. To cool down the secondary fluid, a standard direct expansion fridge system is used.

2.0 INTENDED USE

The dryer has been built to dry the compressed air for industrial use. The dryer cannot be used in premises where there is a risk of fire or explosion or where work is carried out which releases substances into the environment which are dangerous with regard to safety (for example: solvents, inflammable vapours, alcohol, etc.).

In particular the appliance cannot be used to produce air to be breathed by humans or used on direct contact with foodstuffs. These uses are allowed if the compressed air produced is filtered by means of a suitable filtering system (Consult the manufacturer for these special uses.)

This appliance must be used only for the purpose for which it was specifically designed. All other uses are to be considered incorrect and therefore unreasonable. The Manufacturer cannot be held responsible for any damage resulting from improper, incorrect or unreasonable use.

3.0 OPERATION

The gaseous refrigerant coming from the evaporator (8) is sucked by the refrigeration compressor (1) and it is pumped into the condenser (2). This one allows its condensation with the help of the fan (3); the condensed refrigerant passes through the dryer filter (4) and it expands in the expansion valve (7) and goes back to the evaporator where it produces the refrigerating effect. Due to the heat exchange with the thermal mass fluid which passes through the evaporator in counter flow, the refrigerant evaporates and goes back to the compressor for a new cycle.

The thermal mass fluid is then pumped (11) into the heat exchanger (12) where it exchanges heat with the compressed air in counter flow already pre-cooled by the economizer (13). Dependently from the compressed air thermal load, the dryer switches on and off automatically and permits energy saving during the off cycle, keeping the pressure dew point under control with the thermal mass.

DRYER FLOW DIAGRAM

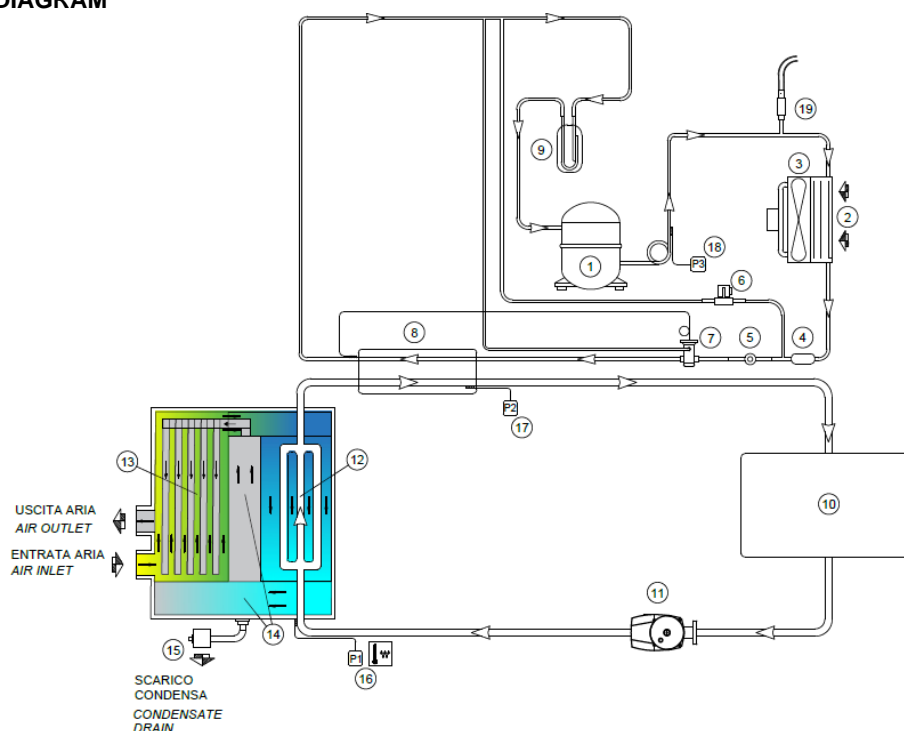

1) COMPRESSOR	11) PUMP
2) REFRIGERANT CONDENSER	12) HEAT EXCHANGER (CHILLER)
3) FAN MOTOR	13) HEAT EXCHANGER (ECONOMIZER)
4) REFRIGERANT FILTER	14) MOISTURE SEPARATOR
5) SIGHT GLASS	15) CONDENSATE DISCHARGE DRAIN
6) SOLENOID VALVE (only single phase versions)	16) P1 SET POINT SENSOR
7) THERMOSTATIC EXPANSION VALVE	17) P2 ANTIFREEZING PROTECTION SENSOR
8) BRAZE-PLATED EVAPORATOR	18) P3 HIGH DISCHARGE TEMPERATURE SENSOR
9) LIQUID SEPARATOR	19) HIGH PRESSURE SAFETY SWITCH
10) TANK	

4.0 GENERAL SAFETY STANDARDS

The appliance may be used only by specially trained and authorized personnel.







Any tampering with the machine or alterations not approved beforehand by the Manufacturer relieve the latter of responsibility for any damage resulting from the above actions.

The removal of or tampering with the safety devices constitutes a violation of the European Standards on safety.



ALL WORK ON THE ELECTRIC PLANT, HOWEVER SLIGHT, MUST BE CARRIED OUT BY PROFESSIONALLY SKILLED PERSONNEL.

5.0 DESCRIPTION OF DANGER SIGNALS

					
1) Dangerous Electric voltage	2) Air not fit for breathing	3) High pressure	4) Fan rotating	5) Hot parts	6) ethylen glycol

6.0 DANGER ZONES

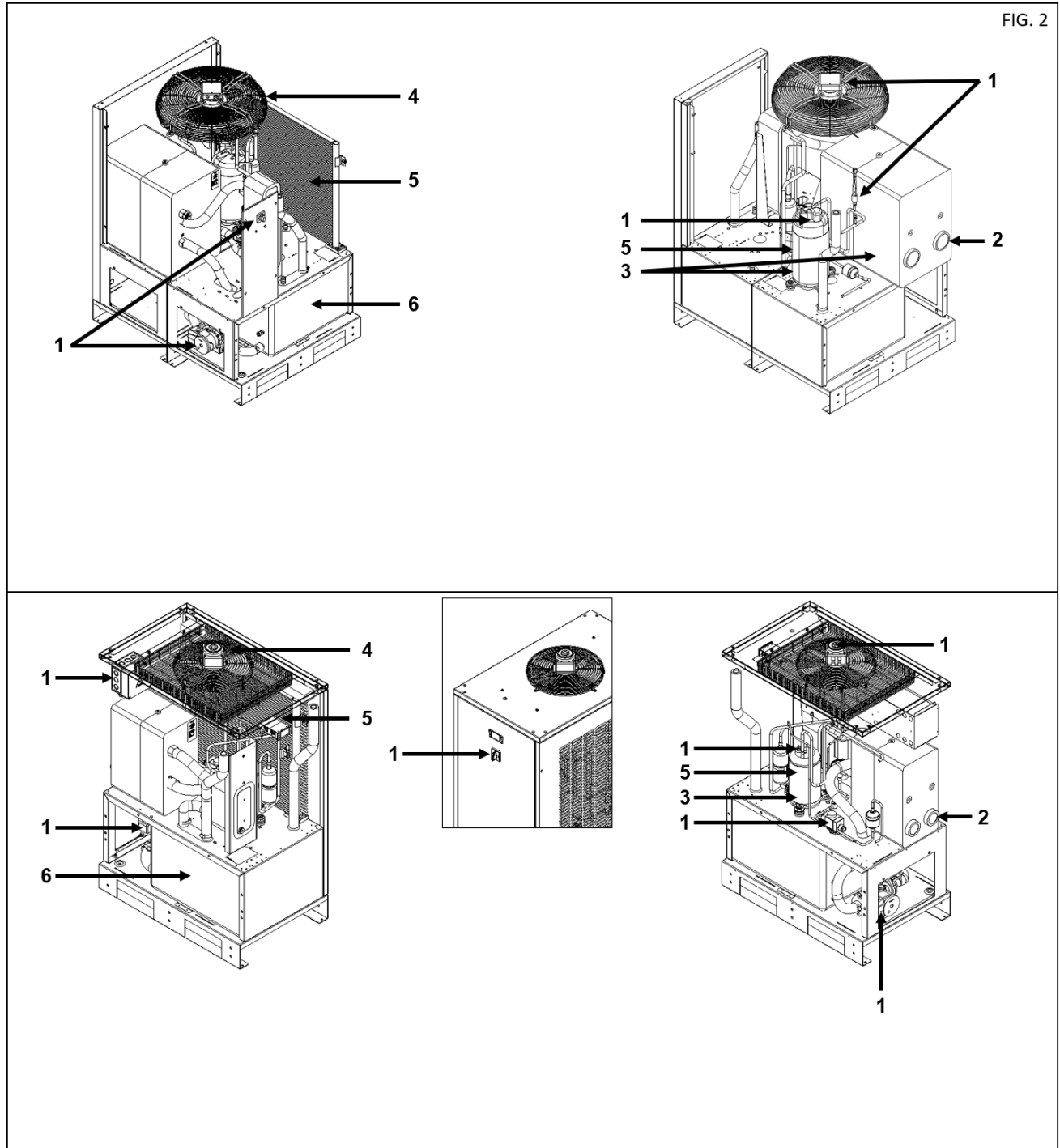
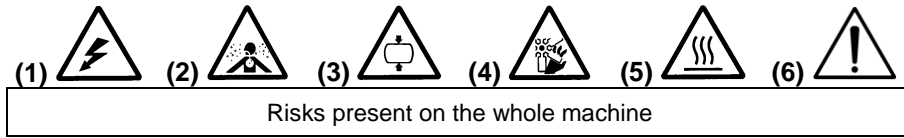

7.0 SAFETY DEVICES

A) Cooling fan shield	B) Earth
C) high pressure side switch	

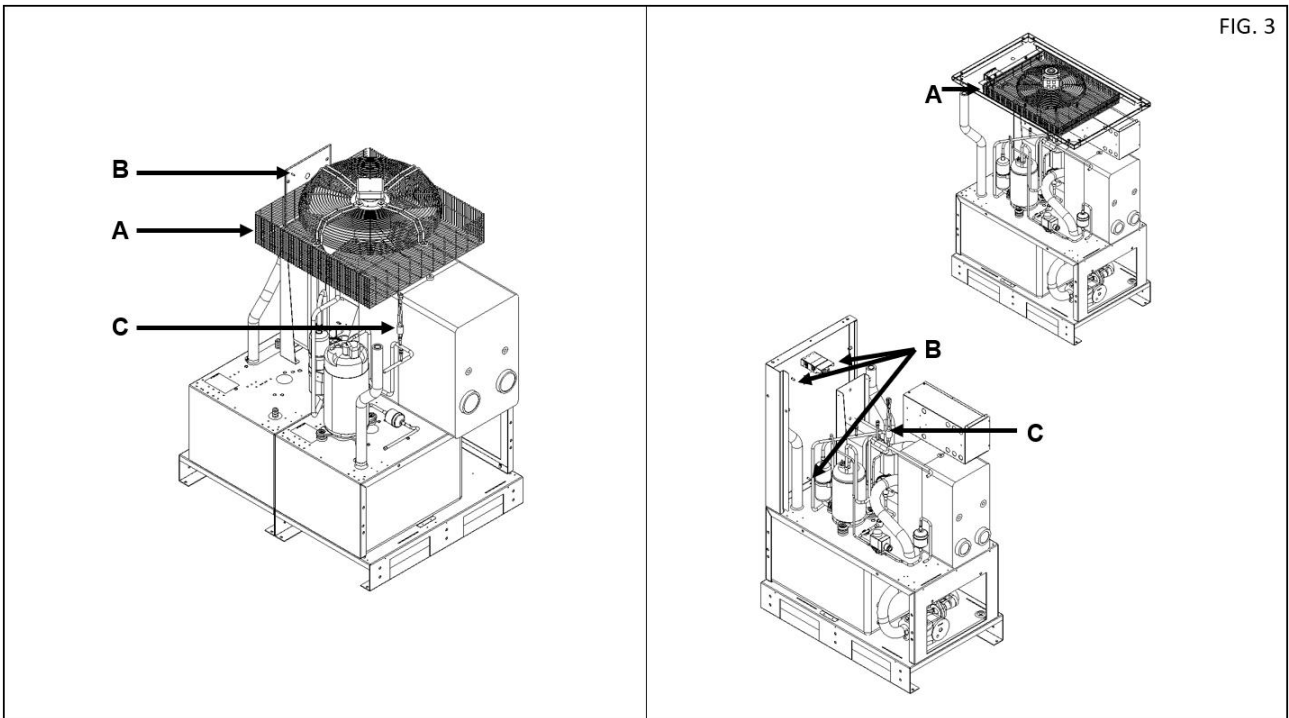

8.0 POSITION OF PLATES (Fig.4)

The plates fitted on the compressor unit are part of the machine; they have been applied for safety purposes and must not be removed or spoiled for any reason.

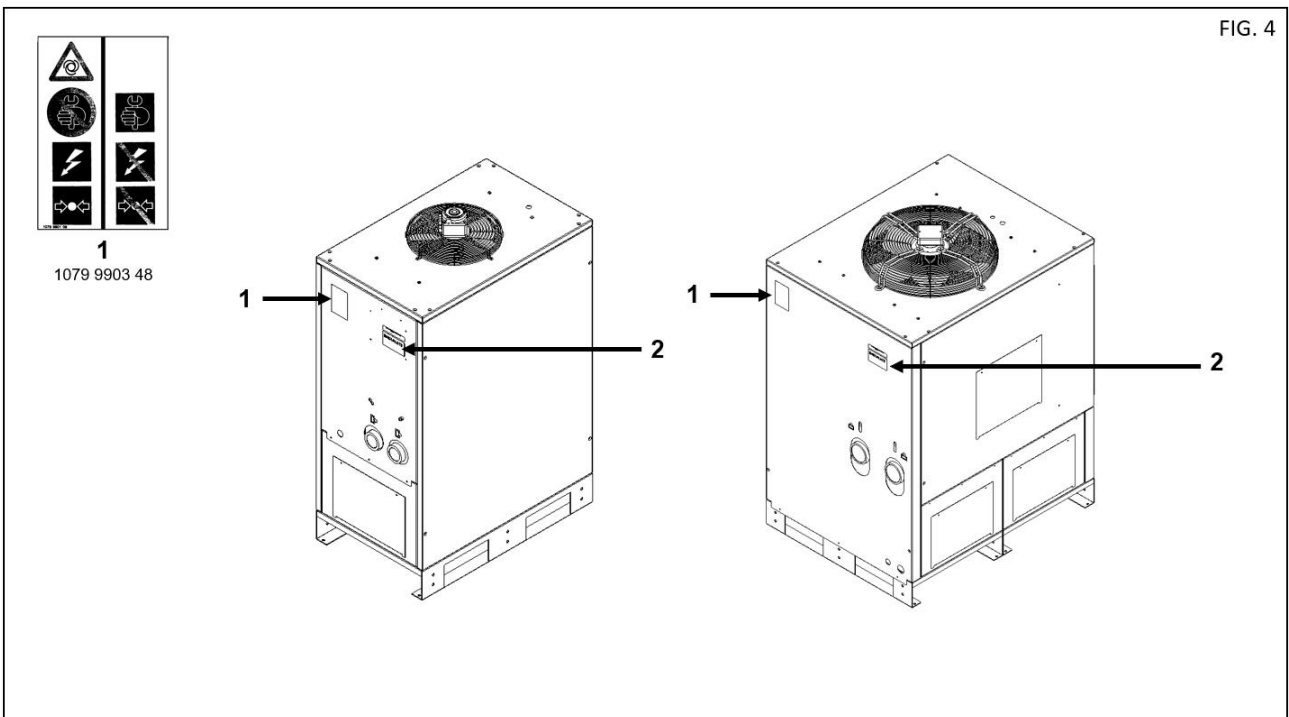

Ref. 1) Danger plate 1079990348	
Ref. 2) Identification plate	

9.0 DRYERS ROOM

9.1 FLOOR

The floor must be even and of industrial type; the total weight of the machine is shown in Fig. 5
Remember the total weight of the machine when positioning it.

9.2 VENTILATION

The choice of an appropriate room will prolong the life of your dryer; the room must be spacious, dry, well ventilated and free from dust.

The operating conditions to be complied with are the following:

Min. room temperature: 41°F (5°C)	Min. inlet allowed temperature: 37,4°F (3°C)
Max. room temperature: 115°F (46°C)	Max. working pressure: 210 psi (14,5 bar)
Max. temperature of incoming air: 140°F (60°C)	

- Please keep environmental conditions stable (temperature and humidity) in order to avoid refrigerant compressor/fan overload and/or reduction of dryer performance. Similar failures shall affect warranty reimbursements.
- Please ensure the appropriate composition of the air within the machine room: - clean with no damaging contaminants (e.g., dust, fibers, fine sand) - free of explosive or chemically unstable gases or vapors - free of acid/alkaline forming substances, particularly ammonia, chlorine or hydrogen sulfide. Similar failures shall affect warranty reimbursements.
- Please remember that we do not recommend the application of duct to extract air in presence of axial fans.

10.0 TRANSPORT AND HANDLING

The machine must be transported from the side indicated in the picture to prevent the overturn of the unit.

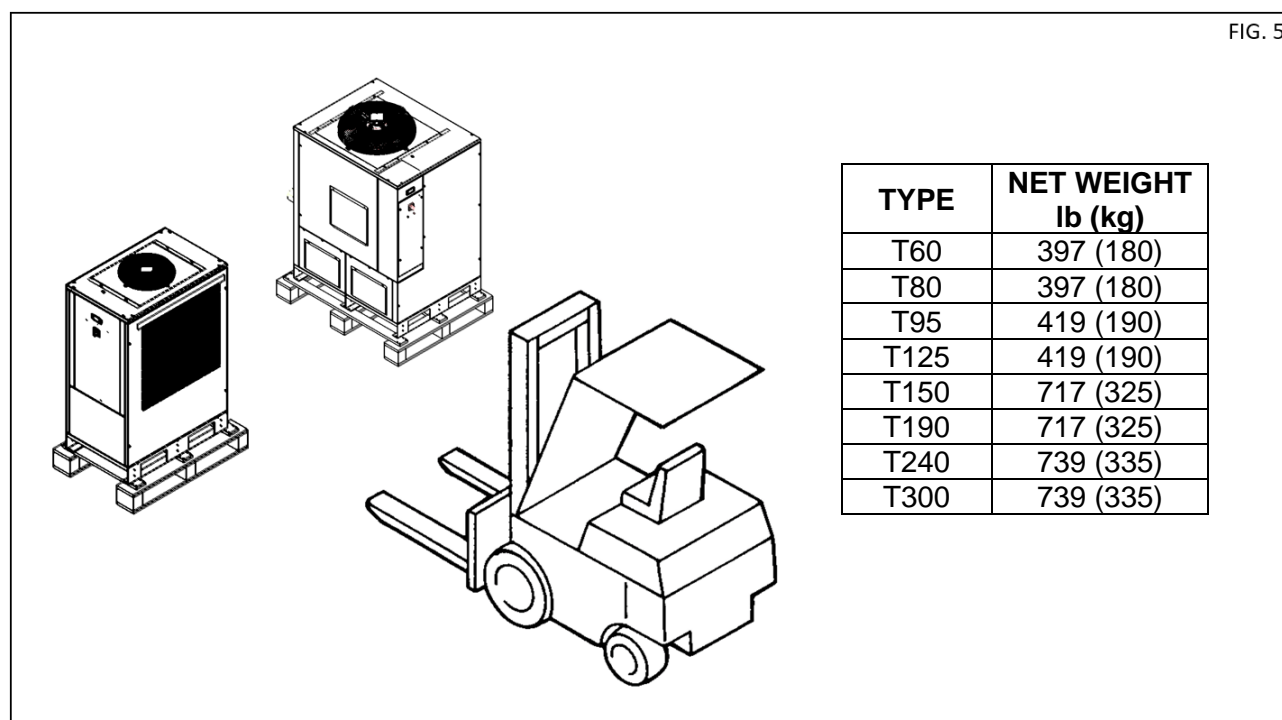

11.0 UNPACKING



CUTTING THE METAL STRAPPING IS A DANGEROUS OPERATION, DO NOT LEAVE THE CUT PIECES IN THE ENVIRONMENT.

After removing the packing, ensure that the machine is unbroken and that there are no visibly damaged parts.
If you are in doubt, do not use the machine but apply to the manufacturer technical assistance service or to your dealer.
The packing material (plastic bags, polystyrene foam, nails, screws, wood, metal strapping, etc.) must not be left within the reach of children or abandoned in the environment, as they are a potential source of danger and pollution. Dispose of these materials in the approved collection centres.

12.0 INSTALLATION

12.1 POSITIONING

After unpacking the equipment and preparing the dryers room, put the machine into position, checking the following items:

- ensure that there is sufficient space around the machine to allow maintenance (see Fig. 6).

ENSURE THAT THE OPERATOR CAN SEE THE WHOLE MACHINE FROM THE CONTROL PANEL AND CHECK THE PRESENCE OF ANY UNAUTHORIZED PERSONS IN THE VICINITY OF THE MACHINE.

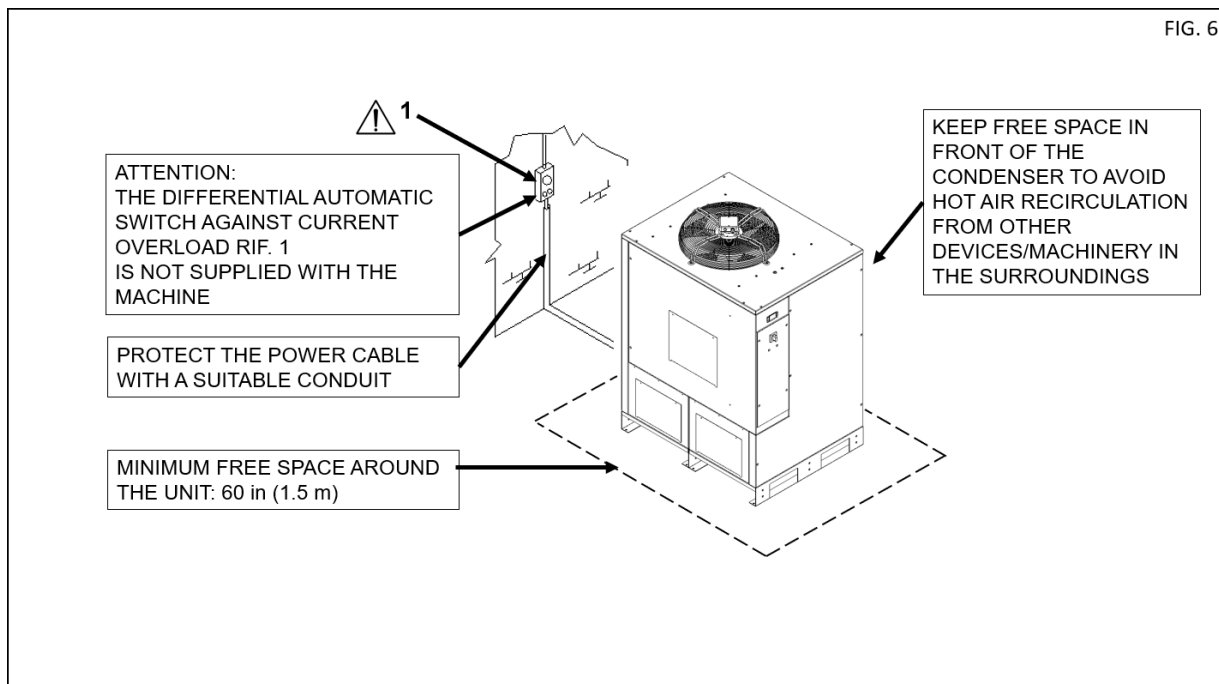

12.2 ELECTRICAL CONNECTION

- Check that the supply voltage is the same as the value indicated on the machine data plate.
- Check the condition of the line leads and ensure that there is an efficient earth lead.
- **Install an automatic cut-out device or a disconnect switch plus time delay fuses, upstream the machine to ensure protection against overcurrent (Ref. 1 Fig. 6). Check the service diagram attached into the electrical panel of the unit.**



ONLY PROFESSIONALLY SKILLED PERSONNEL MAY HAVE ACCESS TO THE ELECTRIC PANEL. SWITCH OFF THE POWER BEFORE OPENING THE DOOR OF THE ELECTRIC PANEL. COMPLIANCE WITH THE REGULATIONS IN FORCE CONCERNING ELECTRIC PLANTS IS FUNDAMENTAL FOR OPERATOR SAFETY AND FOR THE PROTECTION OF THE MACHINE.

12.3 CONNECTION TO THE COMPRESSED AIR NETWORK

Fit a manual interception valve Ref. 1 between the machine and the compressed air network so that the dryer may be isolated during maintenance operations (see figure 7).

Drainage of condensate Rif. 2 Fig. 7 (automatic) are led outside the machine with a flexible pipe that may be inspected. Drainage must comply with the local regulations in force.

- All refrigerant dryers shall be equipped with proper pre-filter at closest position to dryer air inlet (to be replaced according to service plan: once per year or even before in case of particular high humidity ambient conditions).



ALL DAMAGE DUE TO THE FAILURE TO COMPLY WITH THESE INDICATIONS CANNOT BE ATTRIBUTED TO THE MANUFACTURER AND MAY CAUSE INVALIDITY OF THE GUARANTEE CONDITIONS.

12.4 STARTING UP

See part B of this manual, Chapter 16.0

FIG. 7

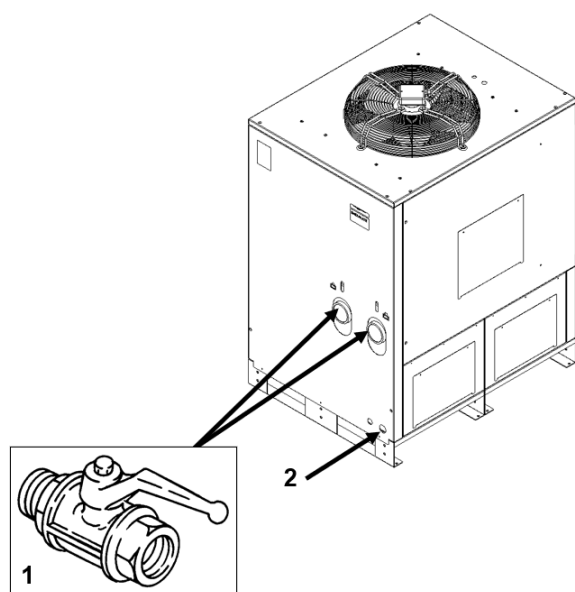

13.0 DIMENSIONS AND TECHNICAL DATA

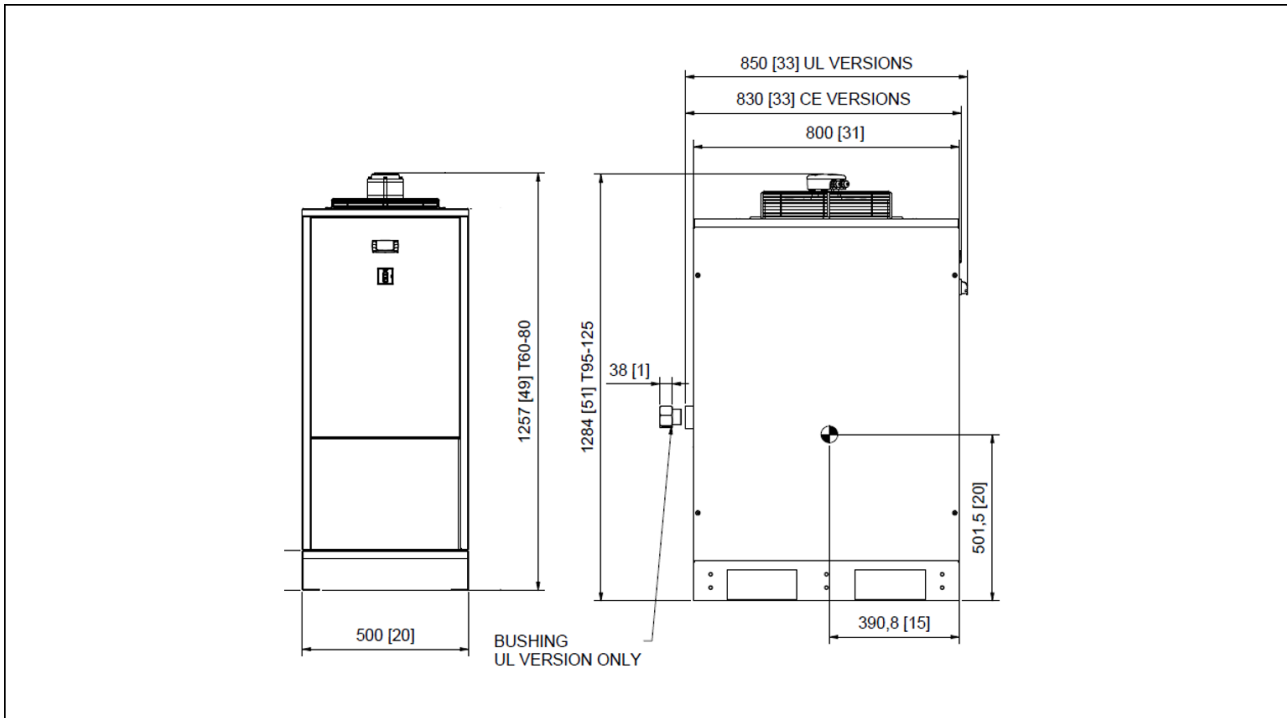

TYPE	50hz	60hz
T60	1 1/2"GAS F	1 1/2"NPT F
T80	1 1/2"GAS F	1 1/2"NPT F
T95	1 1/2"GAS F	1 1/2"NPT F
T125	1 1/2"GAS F	1 1/2"NPT F

Refrigerant gas ⁽¹⁾	GWP ₁₀₀ ⁽²⁾
R-410A	2088
⁽¹⁾ According to ISO 817	
⁽²⁾ According to EN-378-1	

TYPE	Weight lb (kg)	Freon R410A lb (kg)		Thermal mass fluid gal US (l)	Refr compressor Nominal power hp (W)		Fan Nominal power hp (W)		Dryer Nominal Power Hp (W)		Max pressure psi (bar)
		50 Hz	60 Hz		50 Hz	60 Hz	50 Hz	60 Hz	50 Hz	60 Hz	
T60	397 (180)	(0,80)	1,87 (0,85)	13,21 (50)	(593)	1,203 (897)	(75)	0,127 (95)	(668)	1,33 (992)	210 (14,5)
T80	397 (180)	(0,80)	1,76 (0,8)	13,21 (50)	(635)	1,329 (991)	(75)	0,127 (95)	(710)	1,46 (1086)	210 (14,5)
T95	419 (190)	(0,80)	1,76 (0,8)	13,21 (50)	(780)	1,435 (1070)	(130)	0,221 (165)	(910)	1,66 (1235)	210 (14,5)
T125	419 (190)	(0,85)	1,87 (0,85)	13,21 (50)	(958)	2,262 (1687)	(130)	0,221 (165)	(1088)	2,48 (1852)	210 (14,5)

ISO7183 conditions:	50 Hz	60 Hz	Limit conditions:	50 Hz	60 Hz
	Ambient temperature	(25°C)		100°F (38°C)	Max. ambient temperature
Inlet air temperature	(35°C)	100°F (38°C)	Min. ambient temperature	41°F (5°C)	41°F (5°C)
Working pressure	(7 bar)	101,5 psi (7 bar)	Max. inlet air temperature	140°F (60°C)	140°F (60°C)
			Max. working pressure	210 psi (14,5 bar)	210 psi (14,5 bar)

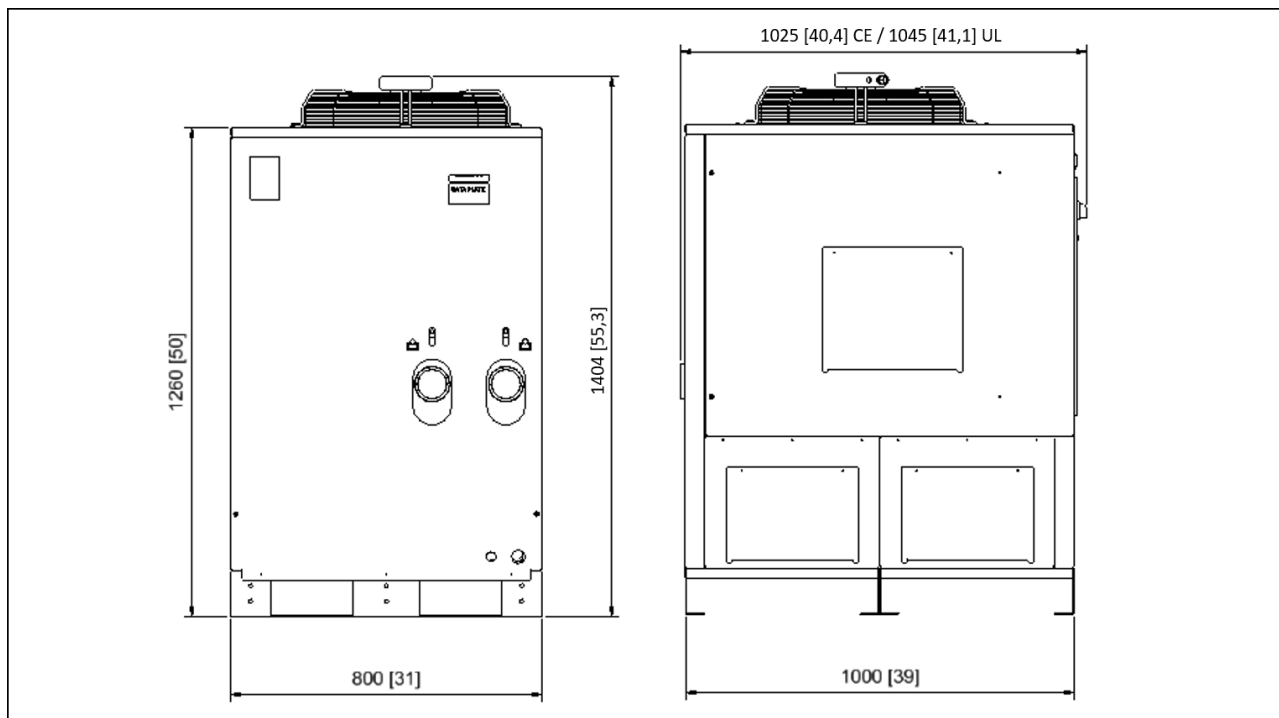

TYPE	50hz	60hz
T150	2" GAS F	2" NPT F
T190	2" GAS F	2" NPT F
T240	2"1/2 GAS F	2"1/2 NPT F
T300	2"1/2 GAS F	2"1/2 NPT F

Refrigerant gas ⁽¹⁾	GWP ₁₀₀ ⁽²⁾
R-410A	2088
⁽¹⁾ According to ISO 817	
⁽²⁾ According to EN-378-1	

TYPE	Weight lb (kg)	Freon R410A lb (kg)		Thermal mass fluid gal US (l)	Refr compressor Nominal power hp (W)		Fan Nominal power hp (W)		Dryer Nominal Power Hp (W)		Max pressure psi (bar)
		50 Hz	60 Hz		50 Hz	60 Hz	50 Hz	60 Hz	50 Hz	60 Hz	
T150	717 (325)	(1,35)	2,98 (1,35)	26,42 (100)	(1280)	2,623 (1956)	(480)	0,684 (510)	(1760)	3,31 (2466)	210 (14,5)
T190	717 (325)	(1,40)	3,09 (1,4)	26,42 (100)	(1649)	3,363 (2508)	(480)	0,684 (510)	(2129)	4,05 (3018)	210 (14,5)
T240	739 (335)	(1,50)	3,31 (1,5)	26,42 (100)	(1805)	3,577 (2667)	(735)	1,61 (1200)	(2540)	5,19 (3867)	210 (14,5)
T300	739 (335)	(1,60)	3,53 (1,6)	26,42 (100)	(2168)	4,659 (3474)	(735)	1,61 (1200)	(2903)	6,27 (4674)	210 (14,5)

ISO7183 conditions:	50 Hz	60 Hz	Limit conditions:	50 Hz	60 Hz
Ambient temperature	(25°C)	100°F (38°C)	Max. ambient temperature	115°F (46°C)	115°F (46°C)
Inlet air temperature	(35°C)	100°F (38°C)	Min. ambient temperature	41°F (5°C)	41°F (5°C)
Working pressure	(7 bar)	101,5 psi (7 bar)	Max. inlet air temperature	140°F (60°C)	140°F (60°C)
			Max. working pressure	210 psi (14,5 bar)	210 psi (14,5 bar)

14.0 MACHINE ILLUSTRATION

14.1 GENERAL LAY-OUT

FIG. 8

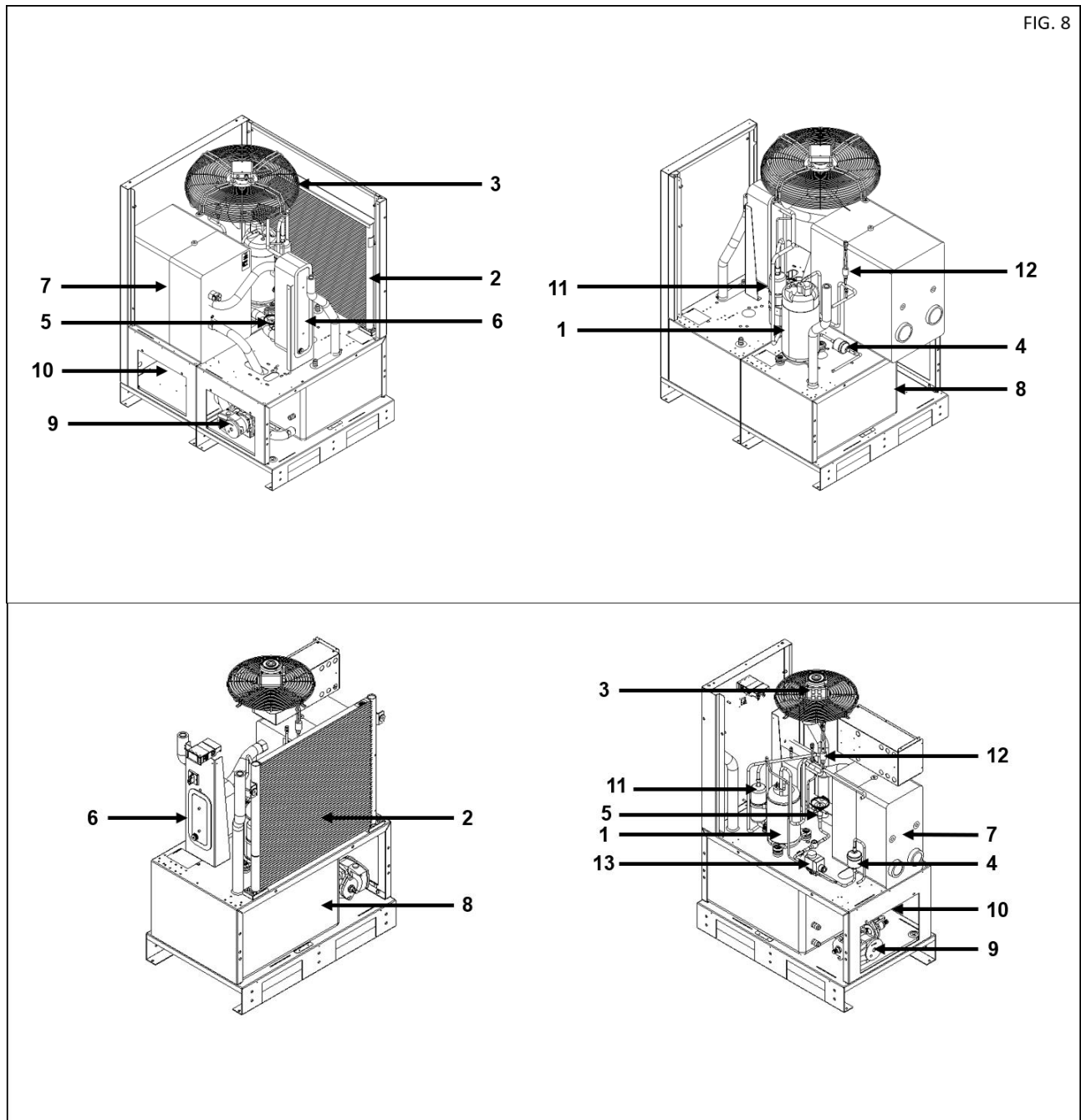

1	Refrigerant compressor
2	Condenser
3	Motor fan
4	Refrigerant filter
5	Expansion valve
6	Evaporator
7	Heat exchanger Water-air
8	Tank
9	Pump
10	Condensate drain
11	Liquid separator
12	Safety pressure switch
13	Solenoid valve

14.2 CONTROL PANEL



BEFORE CARRYING OUT THE OPERATION TEST, READ CAREFULLY AND ACQUIRE A GOOD KNOWLEDGE OF THE COMMAND FUNCTIONS.

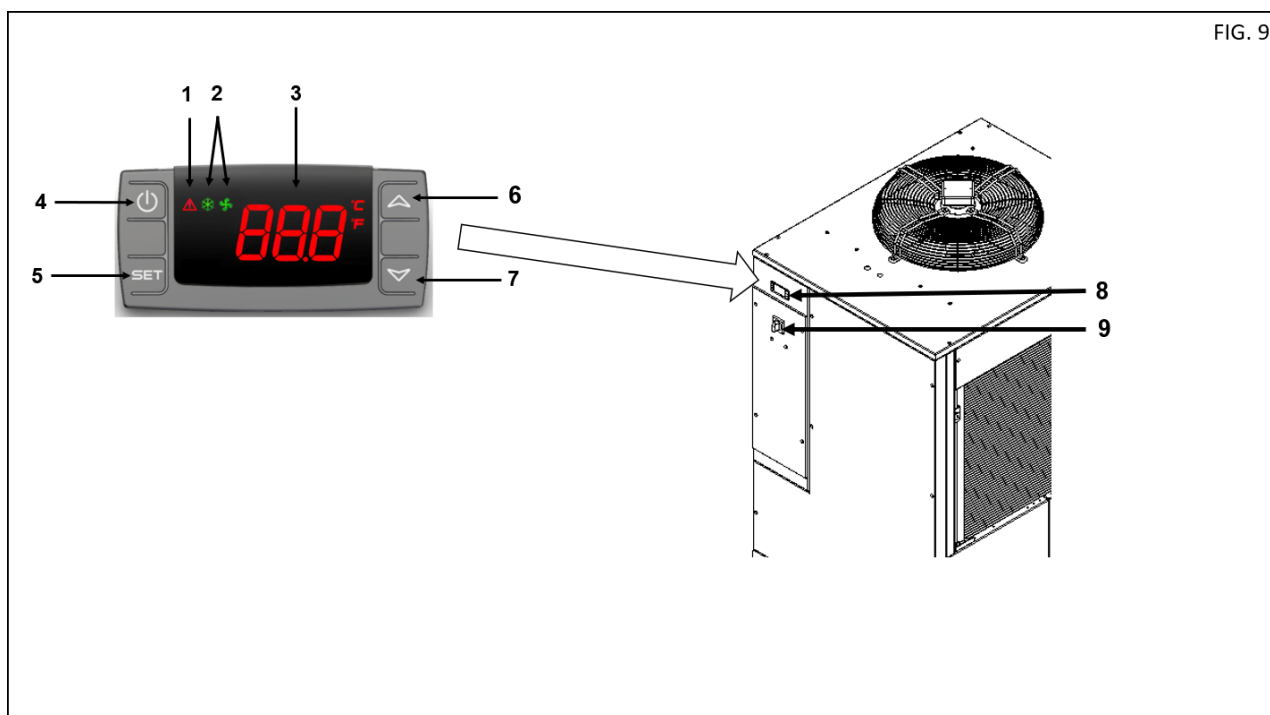



FIG. 9

Reference	Name
1	Alarm / Warning icon
2	Compressor + fan icon
3	PDP indicator
4	ON-OFF button
5	SET button
6	UP button
7	DOWN button
5 + 6	Back to previous screen
5 + 7	Enter in Main Menu
8	Digital controller
9	Main Switch

ICONS

ICON	NAME	MODE	FUNCTIONS
	<i>Alarms and Warning</i>	OFF	No active alarms
		ON + Flashing P1, P2 or P3	Probe failure alarm P1, P2 or P3
		ON	High/Low temperature alarm
		ON + Flashing SE	Maintenance warning
		ON + Flashing L1	Low PDP temperature Alarm, Dryer is stopped
		ON + Flashing H1	High PDP temperature Warning
		ON + Flashing L2	Freezing Alarm in refrigerant circuit, Dryer is stopped
		ON + Flashing H2	High temperature Warning in refrigerant circuit
	<i>Refrigerant compressor + fan</i>	ON + Flashing H3	Too high discharge temperature of the refrigerant compressor (see "H3" pag. 18) Dryer is stopped
		OFF	Compressor + Fan off, PDP < Set temperature
		ON	Compressor + Fan on, PDP > Set temperature
		Flashing + Countdown	Residual time before start for internal pressure balancing.

15.0 SCRAPPING THE UNIT

If the machine is to be scrapped, it must be dismantled into parts of the same material, to be disposed of according to the local regulations in force.

ALWAYS RESPECT THE REGULATIONS IN FORCE FOR DISPOSING OF OLD OIL AND OTHER POLLUTING MATERIALS SUCH AS INSULATING FOAM, ETC.

PART "B"



THIS PART "B" OF THE INSTRUCTIONS MANUAL IS RESERVED FOR PROFESSIONALLY SKILLED PERSONNEL APPROVED BY THE MANUFACTURER.

16.0 ROUTINE MAINTENANCE



BEFORE CARRYING OUT ANY MAINTENANCE JOBS IT IS OBLIGATORY TO STOP THE MACHINE AND DISCONNECT IT FROM THE POWER MAINS AND FROM THE COMPRESSED AIR DISTRIBUTION NETWORK.

16.1 MAINTENANCE SCHEDULE

These maintenance intervals are recommended for work environments that are not dusty and are well ventilated. For particularly dusty environments, double the frequency of controls.

Every week:

Condensate drain: Clean the filter of the automatic condensate drain
Condenser : brush/blow off the finned surface of the condenser

Every 2000h / 1 year:

Replace the filter of automatic condensate drain (2902016102)

Every 4000h / 1 year:

Replace drain kit (2200902017)

16.2 CLEANING OF THE AUTOMATIC CONDENSATE DRAIN FILTER (Fig. 10)

Proceed as follows:

- Close the valve Ref. 1 Fig. 10
- Remove the panel Ref. 5
- Release the pressure in the dryer by pressing the condensate drain "TEST" push button of the drain Ref. 2 Fig. 10.
- Turn-off the unit main switch Ref. 3 Fig. 10
- Turn-off the customer installed electrical protection Ref. 4 Fig. 10
- Remove the cap Ref. 6
- Remove the filter Ref. 7
- Clean/replace the drain filter Ref.7
- Install the filter, fix the plug Ref. 7
- Close the panels Ref. 5

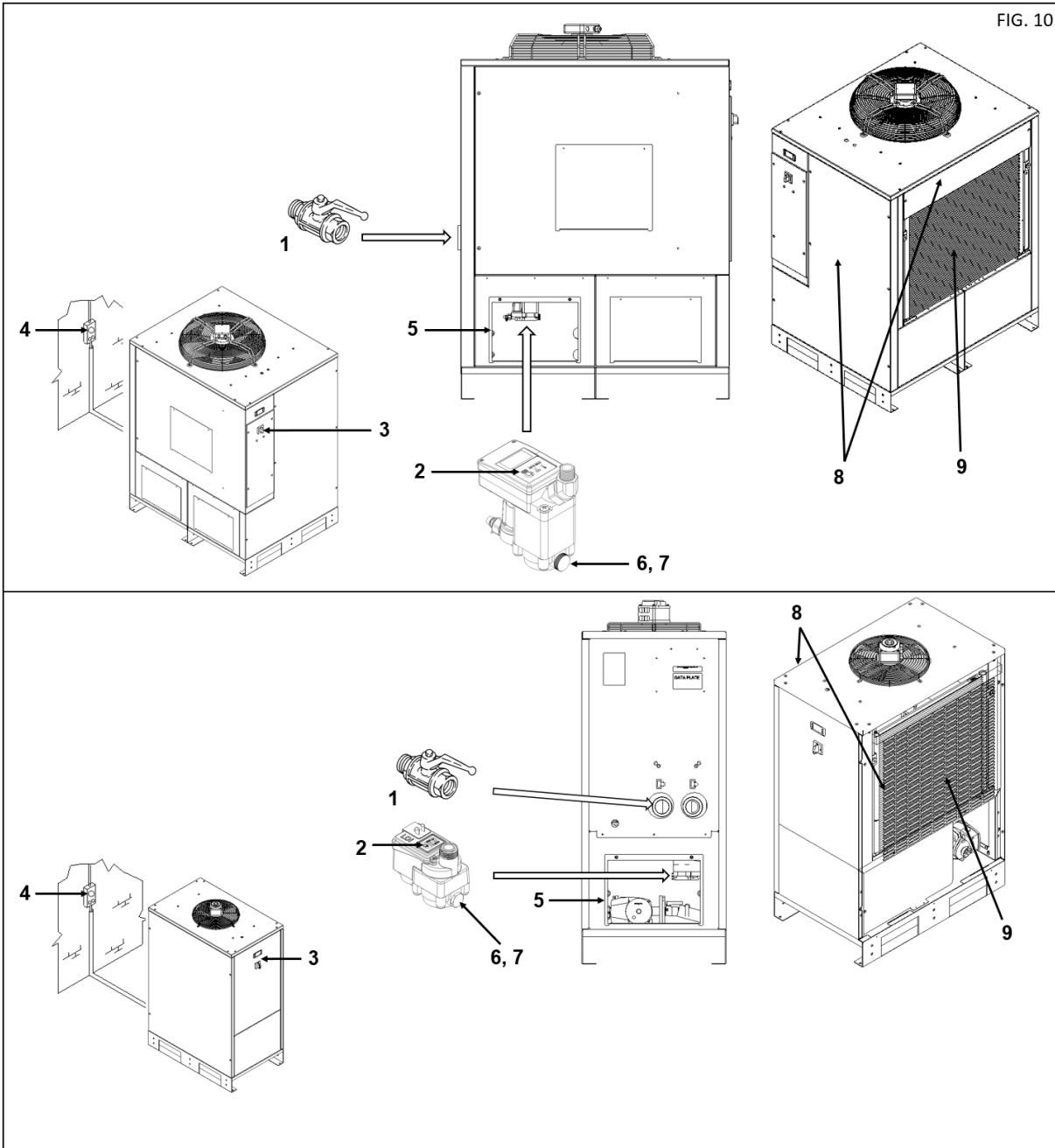

16.3 CLEANING THE CONDENSER (Fig.10)

Proceed as follows:

- Turn-off the unit main switch Ref. 3 Fig. 10
- Turn-off the customer installed electrical protection Ref. 4 Fig. 10
- Remove the panels Ref.8 Fig.10
- Clean the condenser fins with compressed air from inside the unit and use a vacuum cleaner from outside (Fig. 10)
- DO NOT USE WATER OR SOLVENTS**
- re-install the panels before switching-on the unit

17.0 TROUBLE-SHOOTING AND EMERGENCY REMEDIES















ALL WORK MUST BE CARRIED OUT BY PROFESSIONALLY SKILLED PERSONNEL. BEFORE CARRYING OUT ANY MAINTENANCE JOBS IT IS OBLIGATORY TO STOP THE MACHINE AND DISCONNECT IT FROM THE POWER MAINS.

N.B. OPERATIONS MARKED ■ ■ MUST BE CARRIED OUT BY PROFESSIONALLY SKILLED PERSONNEL APPROVED THE MANUFACTURER

FAULT FOUND	POSSIBLE CAUSES	OBSERVATIONS
1) No compressed air passes through the dryer outlet	1A) The pipes are frozen inside	■ ■ -The room temperature is too low and the evaporators piping are obstructed with ice
2) Presence of condensate in the pipings.	2A) The condensate drain does not work correctly 2B) The dryer is working outside its rating 2C) The dryer is working under bad conditions of condensation 2D) The Pump get stuck or the thermal mass circuit isn't working well 2E) High pressure switch trips or fan protection trips	■ ■ -Clean the filter of the condensate drain ■ ■ -Check the condensate drain -Check the flow rate of treated air -Check the room temperature -Check the air temperature at the dryer inlet. ■ ■ -Clean the condenser. ■ ■ -Check the operation of the fan ■ ■ -If L2 alarm appears see Pag.15, 17.1. Check also Pag.19 16.4 ■ ■ Clean the condenser and reset the high pressure switch, see Pag.14, 16.3.
3) The compressor head is very hot (>110°C)	See 2B above See 2C above 3A) The cooling circuit is not working with the right gas charge	■ ■ - See allarm "H3" pag. 15, 17.1 ■ ■ - Check if there are leaks of refrigerating gas. ■ ■ - Charge it again.
4) Motor cuts out on overload	See 2B above See 2C above See 3A above	
5) The motor hums and does not start.	The line voltage is too low. The starting system of the motor is defective.	-Contact the electric power company ■ ■ -Check the running capacitor
6) The machine has stopped and does not restart even after a few minutes.	The overload protection or high pressure switch have tripped: see 2B-2C-3A. The motor is burned.	
7) The compressor is very noisy.	Troubles with the internal mechanical parts or with the valves	

17.1 TROUBLE-SHOOTING AND EMERGENCY REMEDIES

N.B. OPERATIONS MARKED ■ ■ MUST BE CARRIED OUT BY PROFESSIONALLY SKILLED PERSONNEL APPROVED THE MANUFACTURER

Disply	Flashing fault message	Description	Possible root causes	Observations
		Dryer is working OK	n/a	n/a
		Alarm icon + label P1 flashing	Thermal mass fluid control probe failed	■ ■ replace probe kit
		Alarm icon + label P2 flashing	Thermal mass protection probe failed	■ ■ replace probe kit
		Alarm icon + label P3 flashing	Refrigerant compressor temperature probe failed	■ ■ replace probe kit
		Warning icon + label H2 flashing	High refrigerant temperature	<ul style="list-style-type: none"> ■ ■ refrigerant leak ■ ■ too high flow rate / inlet ■ ■ working temperature exceeding the limit. ■ ■ High pressure switch trips or fan protection trips.
		Alarm icon + label L2 flashing	Anti-freezing protection	<ul style="list-style-type: none"> ■ ■ pump get stuck (see pag.19, 16.5). ■ ■ possible thermal mass fluid leak (see pag.19, 16.4)
		Alarm icon + label H3 flashing	High discharge compressor temperature	<ul style="list-style-type: none"> ■ ■ refrigerant leak ■ ■ too high flow rate / inlet ■ ■ working temperature exceeding the limit.
		Warning icon + label H1 flashing	High PDP	<ul style="list-style-type: none"> ■ ■ too high flow rate / inlet ■ ■ working temperature exceeding the limit. ■ ■ High pressure switch trips or fan protection trips.
		Alarm icon + label L1 flashing	Low PDP	■ ■ check probe

EE ALARM

EE alarm is shown when internal EPROM errors happens. The unit can operate continuously without damaging the components. The error can be reset by pressing one of the four buttons of the controller, anyway replace the controller itself.







NOTE: In case of EE alarm contact Customer Service

SE ALARM

After 6000Hrs, the controller will issue a "SE" warning. This is the maintenance due warning.





How to reset the maintenance warning: follow steps 1 to 12

1	 <p>PDP is flashing between standard view and "SE" alarm</p>	2	3
4	 <p>Push and release button "UP" until "rS" parameter appear.</p>	5	6
7	 <p>Message "n" appears on display.</p>	8	9
10	 <p>Push and release "SET" to reset service alarm.</p>	11	12

PROCEDURE TO SET THE SERVICE INTERVAL ON PDP DEVICE

1		2		3	
	<p>PDP is showing standard view.</p>		<p>Push and hold buttons "SET" and "DOWN" to enter in the menu.</p>		<p>First menu parameter "St" appears on display. Push up arrow until "SE" parameter is shown.</p>

4		5		6	
	<p>Push and release "SET" to enter in the "SE" menu.</p>		<p>Current service interval is displayed. ("60" or different value from "0" to "99")</p>		<p>Select desired service interval using "UP" or "DOWN". (40=4000h, 55=5500h, 80=8000h,...)</p>

7		8		9	
	<p>Push and release "SET" to configure new service interval.</p>		<p>Value selected blinks for 3 seconds.</p>		<p>Then "rS" is fixed and "°C or F" New service interval is set</p>

HOW TO RESET AN ALARM

Restart the dryer without a deep investigation on possible root cause will affect the reliability of the dryer and overrule the warranty reimbursement.

Press button Ref. 7 Fig. 9 to reset the alarm.

17.2 THERMAL MASS FLUID (Fig. 11)

CONTACT PROFESSIONALLY SKILLED PERSONNEL APPROVED BY MANUFACTURER AND INSIST ON THE USE OF ORIGINAL SPARE PARTS.

THE THERMAL MASS FLUID IS A MIXTURE QUALIFIED BY THE MANUFACTURER. DON'T USE DIFFERENT FLUID FROM THE ONES SUGGESTED BY YOUR DEALER

In case of strong leakage of thermal mass fluid proceed as follow:

- a) Switch-off the unit Ref. 3 Fig. 11
- b) Turn off the supply (see disconnecter switch Ref. 4 Fig. 11)
- c) Remove the panel Ref. 1 Fig. 11
- d) Identify the leak, fix it and clear carefully the fluid into and around the unit
- e) Identify the filling and venting hoses Ref.2,7 Fig.11 and remove the cap on top of them
- f) Check the thermal mass fluid residual level, with a metallic rod Ref.5 Fig.11, going into the venting hose to the bottom of the tank
- g) If the level is close to the value Ref.6 Fig.11, the quantity of fluid is still ok
- h) If the level is lower, fill the tank with proper fluid until the optimal level (25 cm approx from baseframe)
- i) Close the venting and filling hoses with the original cap
- j) Close the front panel
- k) Vent the pump like it was a first start-up, to evacuate air inclusions in the hydronic circuit (see Starting-up Pag.24, 18.0)

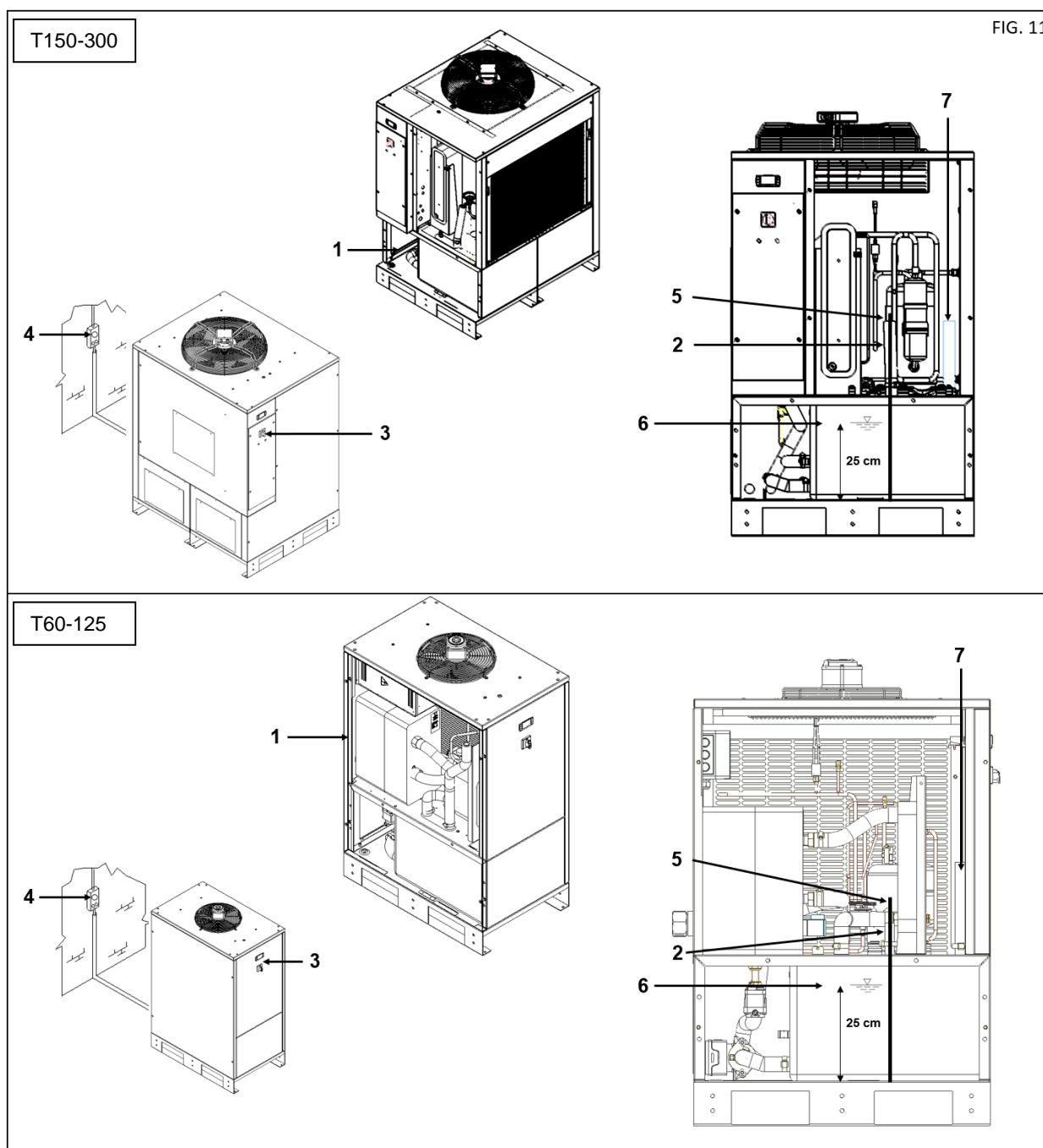

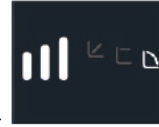
17.3 PUMP BLOCKED (Fig. 12)

In case the impeller get stuck, the vertical bars of the display flashes two (2) times →

- a) Switch-off the unit Ref. 3 Fig. 12
- b) Turn off the supply (see disconnecter switch Ref. 4 Fig. 12)
- c) Remove the panels Ref. 1 Fig. 12
- d) Unscrew the plug in the center of the pump body with a screwdriver or a coin Ref. 2 Fig. 12

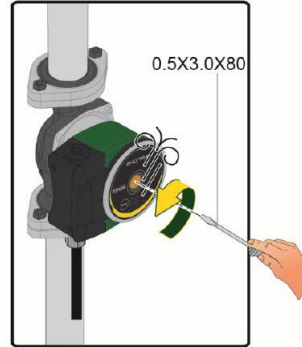

- e) Access the impeller and rotate it clockwise with a screwdriver
- f) Switch-on the unit and check with a lamp that the impeller is rotating. Wait until a droplet of fluid goes out.
- g) Switch-off again the unit (step a) and b))
- h) Restore the plug of the pump
- i) Dry eventual residuals of fluid
- j) Close the panel Ref.1 Fig.12
- k) Restart the unit

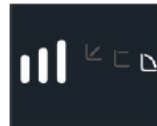

In case the vertical bars of the display flashes three (3) times →

- a) Switch-off the unit Ref. 3 Fig. 12
- b) Turn off the supply (see disconnecter switch Ref. 4 Fig. 12)
- c) Check all the pump electrical connections and fix any potential issue
- d) Restart the unit

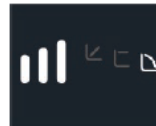

In case the vertical bars of the display flashes four or five (4-5) times →

- a) Switch-off and on again the unit Ref.3 Fig.12.
- b) If the problem persists, replace the pump

FIG. 12

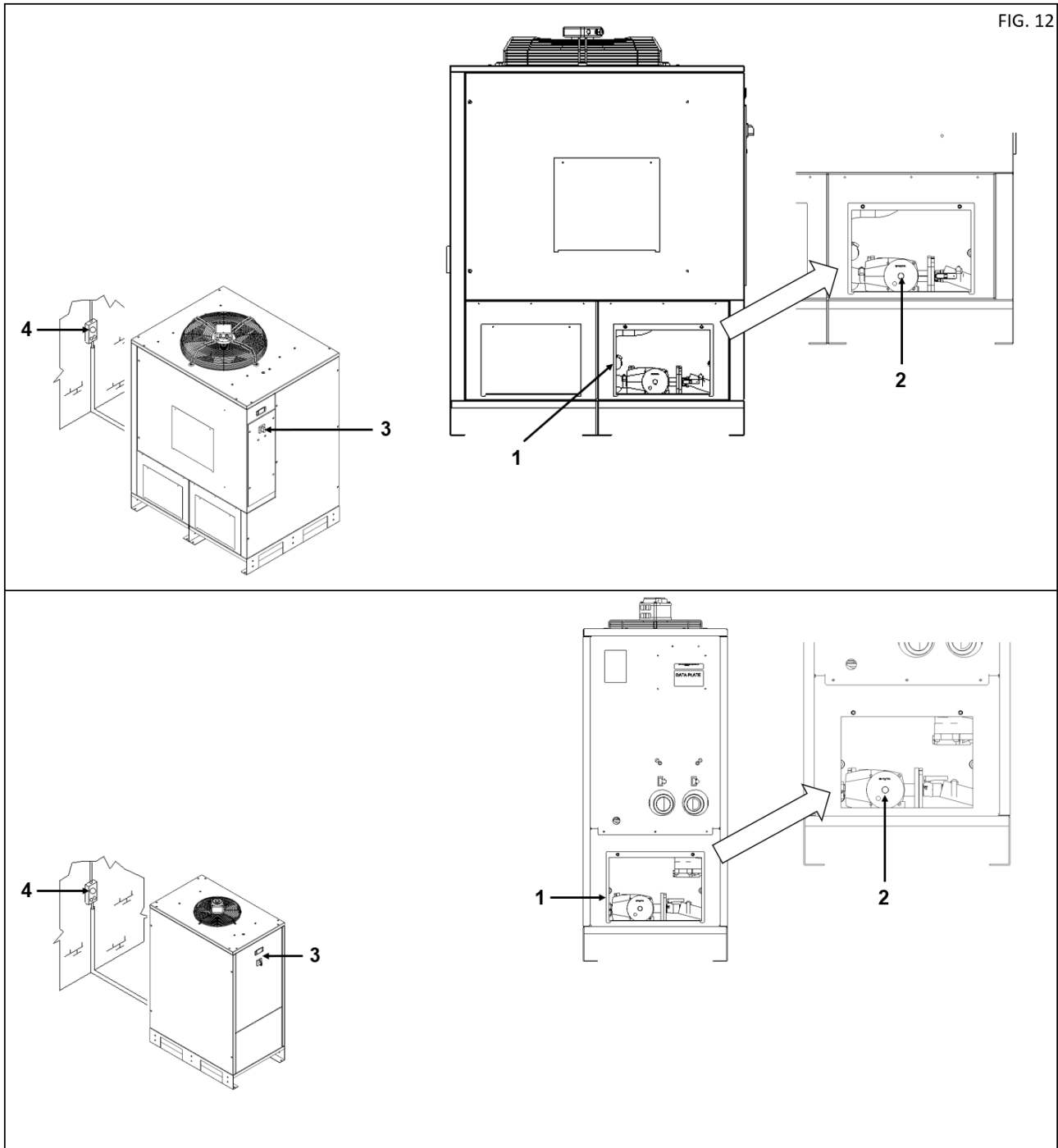

18.0 STARTING UP, CONTROLLER FEATURES

BEFORE CARRYING OUT ANY OPERATION ON THE MACHINE, ENSURE THE ELECTRIC POWER SUPPLY HAS BEEN DISCONNECTED WAIT AT LEAST TWO HOURS BEFORE STARTING UP, AFTER ANY MACHINE MOVEMENT (TRANSPORT OR HANDLING).

18.1 PRELIMINARY CONTROLS

Before starting the dryer, check:

- The correct connection to the compressed air piping: remember to remove eventual caps on the dryer inlet and outlet.
- The correct connection to the condensate drainage system.
- The power supply has properly connected following the instruction into this manual and checking the service diagram
- There are no leak of fluid inside and around the unit

18.2 STARTING AND STOP

This dryer contains a thermal mass, needs up to 20 minutes to be cooled at the first start-up, depending from the ambient temperature. It's suggestable to start-up the dryer before start supplying compressed air. The power consumption of the dryer without compressed air is negligible, so it's suggestable to keep the dryer always on.

- Remove the panel Ref.1 Fig.12 to see the pump
- Remove the central cap of the pump Ref. 2 Fig. 12 with a coin or a screw driver to see the main shaft

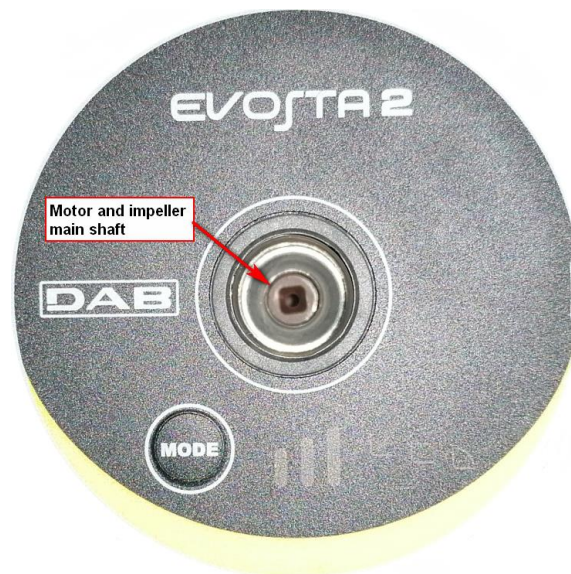

- Turn on the switch Ref.4 Fig.12
- Turn on the switch Ref.3 Fig.12



- The display of the controller will show OFF state



- Press the start button  for 5 seconds, the pump will start, the display will show a countdown of 60 seconds
- Check with a lamp the rotation of the impeller (the main shaft squared shape in the picture above becomes rounded)
- Check that a small quantity of fluid flows from the shaft. It means the pump has been vented.
- Turn off the switch Ref.3 Fig.12
- Turn off the switch Ref.4 Fig.12
- Restore the central plug Ref. 2 Fig. 12
- Close the panel Ref.1 Fig.12
- Turn on the switch Ref.4 Fig.12
- Turn on the switch Ref.3 Fig.12

18.3 REMOTE ALARM FUNCTION

The controller allows to remote alarms and warnings. This is managed by means of a free NC (Normally Closed) contact. The contact opens in case of an alarms, warnings and other abnormal state of the controller. Refer to pictures below to identify the free contact location into the unit.



Location of the free contact connector for T60-125

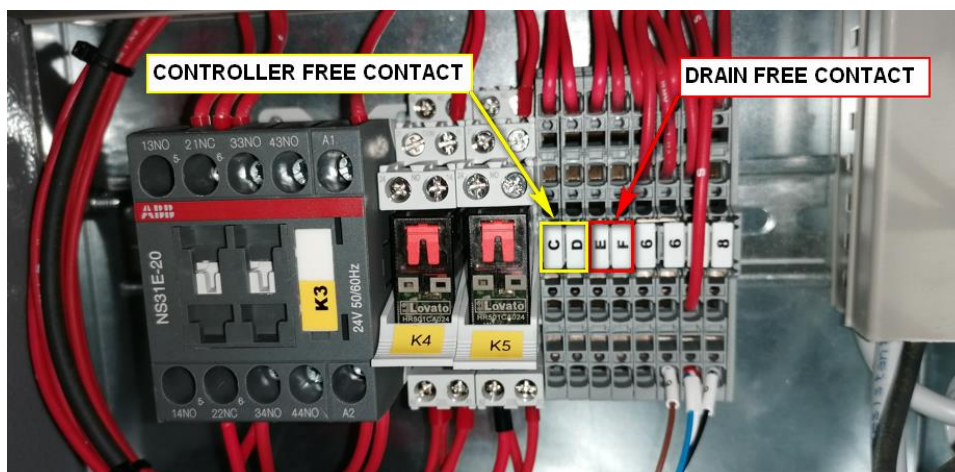

Location of the free contact connectors for T150-300

18.4 REFRIGERANT COMPRESSOR DISCHARGE TEMPERATURE VISUALIZATION FUNCTION

To check the discharge refrigerant compressor temperature, follow steps 1 to 5:

1. PDP is showing standard view.
2. Push and hold buttons SET (5) and DOWN (7) to enter the menu.
3. Push and release the UP button (6) until message "S3" appears on display.



4. Push and release the SET button (5) to enter the "S3" parameter.
5. Current temperature of discharge refrigerant compressor is displayed.

